INSTALLATION INSTRUCTIONS

RHEEM FLUE TERMINAL DIVERTER WITH HEAT SHIELD (PN 299287)

RHEEM EXTENDED FLUE TERMINAL DIVERTER WITH HEAT SHIELD (PN 299285)

This instruction details the installation of the Rheem Flue Terminal Diverter with Heat Shield (PN 299287) and the Rheem Extended Flue Terminal Diverter with Heat Shield (PN 299285) to the Rheem Electronic Continuous Flow Gas water heater models noted below (refer to the rating plate for model number):

874826NF, 874T26NF	(26L/min 60°C, Natural Gas, Frost Protected)
876826NF, 876T26NF	(26L/min 50°C, Natural Gas, Frost Protected)

⚠ Warning: Fitting of a Flue Terminal Diverter or Extended Flue Terminal Diverter to Rheem models other than those identified above can result in a potentially unsafe condition.

SETTING BURNER GAS PRESSURE OF THE WATER HEATER

It is necessary to check the burner gas pressure at both the minimum and maximum operational settings. To check and if necessary adjust the operational gas pressures, the electrical supply to the water heater must be switched on, the burners ignited and hot water must be flowing from a hot tap.

⚠ Warning: The removal of the front panel will expose 240 volt wiring. Take care not to touch wiring terminals.

Note: If an 874 series model is installed as an in-series gas booster for a solar water heater, then during this procedure the temperature of the water entering the in-series gas booster must be below 58°C. Otherwise the gas burners will not ignite and the operational gas pressures cannot be measured.

1. Close any hot taps and ensure the burners are not operating.
2. Turn off the controller(s), if one is fitted, by pressing the on / off (⏻) button and switch off the electrical supply at the power outlet to the water heater.
3. Remove the top and bottom cover strips to gain access to the front cover screws by pressing on the two ridged finger points and gently pulling forward.
4. Remove the screws holding the front panel to the jacket.
5. Gently disengage the front panel and pull forward to remove from the water heater.
6. Locate the burner pressure test point on the main burner manifold
 - Remove the test point screw and washer from the test point orifice.
 - Connect the manometer.
7. Switch on the electrical supply at the power outlet to the water heater and turn on a controller, if one is fitted, by pressing the on / off (⏻) button.
8. The priority light and the on / off operating light will both glow.
9. Open the gas isolation valve fully at the gas inlet to the water heater, if not already open.

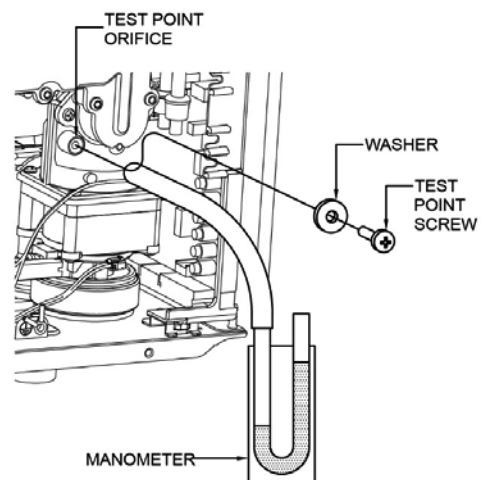

Minimum Test Point Gas Pressure

10. Refer to the rating label on the water heater for the minimum test point gas pressure.
11. Open a hot tap slowly until the burners ignite.

12. Press and hold down the MIN button and observe the reading on the manometer.

- "1L" is shown on the LED display.

13. Release the MIN button.

14. If the manometer reading observed in step 12 agrees with the rating label, no further adjustment is required.

15. To adjust, press and hold down the adjuster button.

- "LH" is shown on the controller display.

Note: The adjuster button must be held down continuously through steps 15 to 17.

16. Press and hold down the MIN button and observe the reading on the manometer.

- The manometer reading will change as the test point gas pressure adjusts.

Note: While the MIN button is pressed, the gas pressure will at first increase then decrease, cycling between an upper gas pressure limit (59 on the LED display) and a lower gas pressure limit (01 on the LED display).

17. Release the MIN button when the reading on the manometer agrees with the rating label.

18. Release the adjuster button.

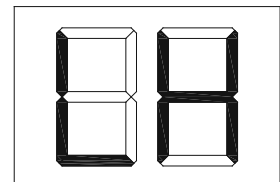
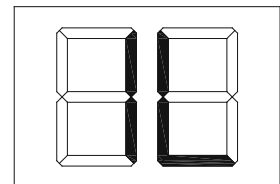
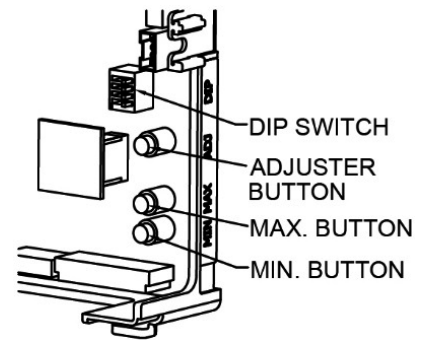

Notes:

- If the burners extinguish and an error code 11 or 12 starts to flash on the LED display:
 - release the MIN and adjuster buttons
 - close the hot tap
 - clear the error code (refer to Owner's Guide and Installation Instructions supplied with the water heater)
 - recommence the procedure from Step 11.
- If the adjuster button is released before Step 17, clear any error code (if displayed) and recommence the procedure from Step 11.

Maximum Test Point Gas Pressure

19. Refer to the rating label on the water heater for the maximum test point gas pressure.
20. To check and adjust the maximum test point gas pressure, follow steps 11 to 18 of the “Minimum Test Point Gas Pressure” procedure, but;
 - open the hot tap fully (it may be necessary to open two or three hot taps fully, depending upon the incoming cold water temperature), and
 - use the MAX button instead of the MIN button.

Notes:

- In Step 15, “6H” will be shown on the LED display.
- In Step 16 while the MAX button is pressed, the gas pressure will at first increase then decrease, cycling between an upper gas pressure limit (39 on the LED display) and a lower gas pressure limit (01 on the LED display).

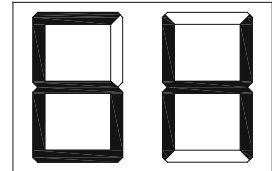

21. After setting the minimum and maximum test point gas pressures:
 - Close the hot tap
 - Remove the manometer and refit and tighten the test point screw and washer.
22. Open a hot tap again so the burners ignite and test for gas leaks.
23. Close the hot tap and turn off the controller, if one is fitted, by pressing the on/off (⏻) button.
24. Switch off the electrical supply at the power outlet to the water heater.
25. Refit the front cover, re-installing the 4 x screws, ensuring that the star-washer and screw are re-inserted into the same hole as originally installed at the factory (the star-washer ensures earthing of the front cover panel). **Do not tighten the upper two screws at this stage.**
 - Fit one of the cover strips to the bottom of the front cover by inserting the two posts into the two recesses and gently pushing into position.
 - Do not fit a cover strip to the top of the front cover as the Flue Terminal Diverter makes it obsolete.

DIVERTER INSTALLATION

Note: The Flue Terminal Diverter or Extended Flue Terminal Diverter packed in the carton is factory assembled with a metal heat shield. The heat shield forms an integral part of the flue diverter and **MUST NOT** be detached. **DO NOT** install the flue terminal if any of the components are missing.

1. Remove all packaging from the Flue Terminal Diverter or Extended Flue Terminal Diverter.
2. The Flue Terminal Diverter or Extended Flue Terminal Diverter (1), 4 x stainless steel mounting brackets (2A, 2B), (3), (4) and screws (5) are required to be attached to the water heater. The wall mounting bracket short (7) or long (8) and screws (9), (10) and washers (11) are used with the Extended Flue Terminal Diverter and are required to be attached to the wall and flue diverter. Refer to the diagrams, "Flue Terminal Diverter Details" and "Extended Flue Terminal Diverter Details".

Familiarise yourself with the placement of each bracket in relation to the Diverter and the Rheem continuous flow water heater front panel before attempting the installation.

Note: The Flue Terminal Diverter or Extended Flue Terminal Diverter can be orientated in either direction. The Flue Terminal Diverter Details diagram illustrates the left hand flue outlet installation, and the Extended Flue Terminal Diverter Details diagram illustrates the right hand flue outlet installation.

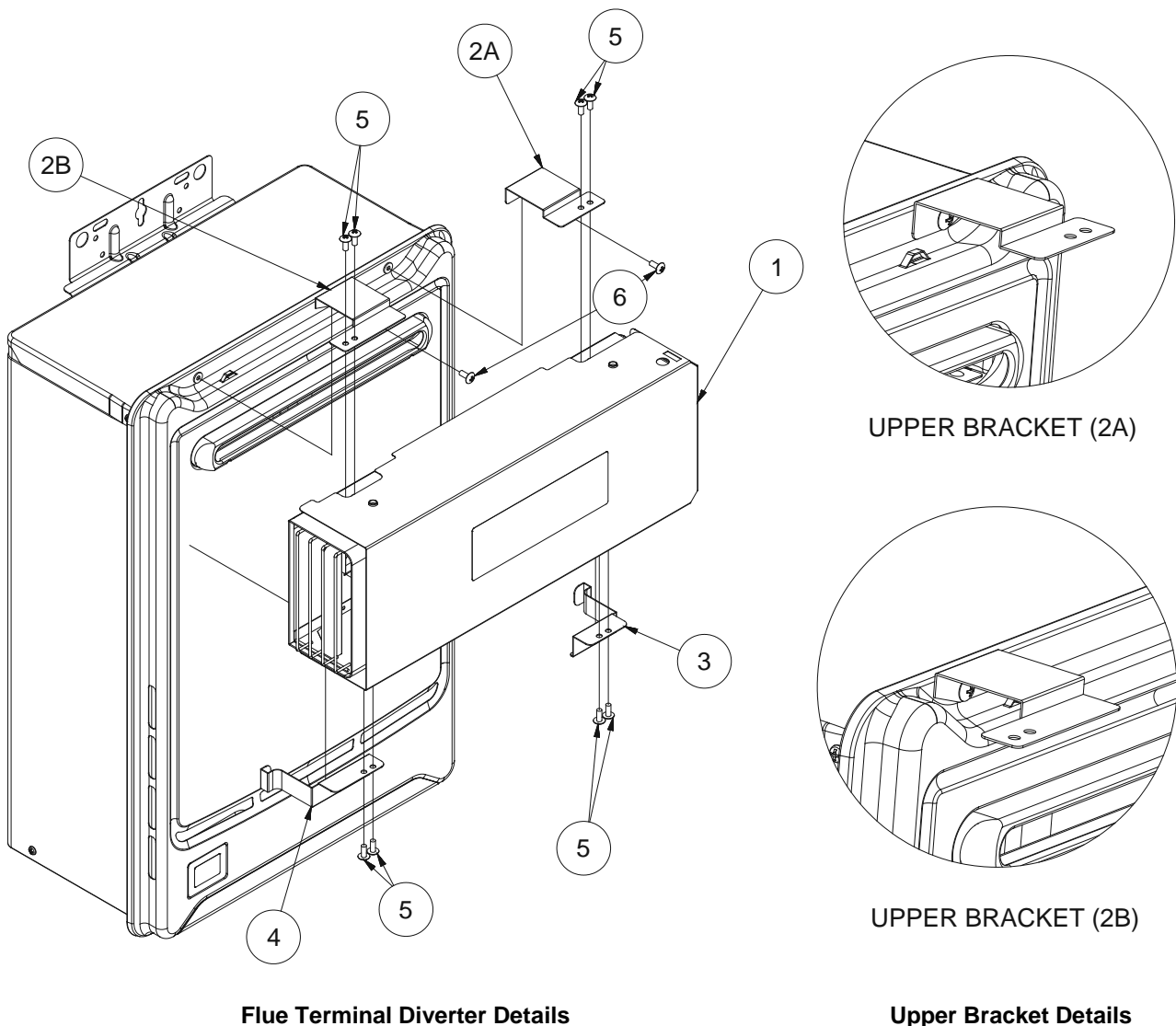

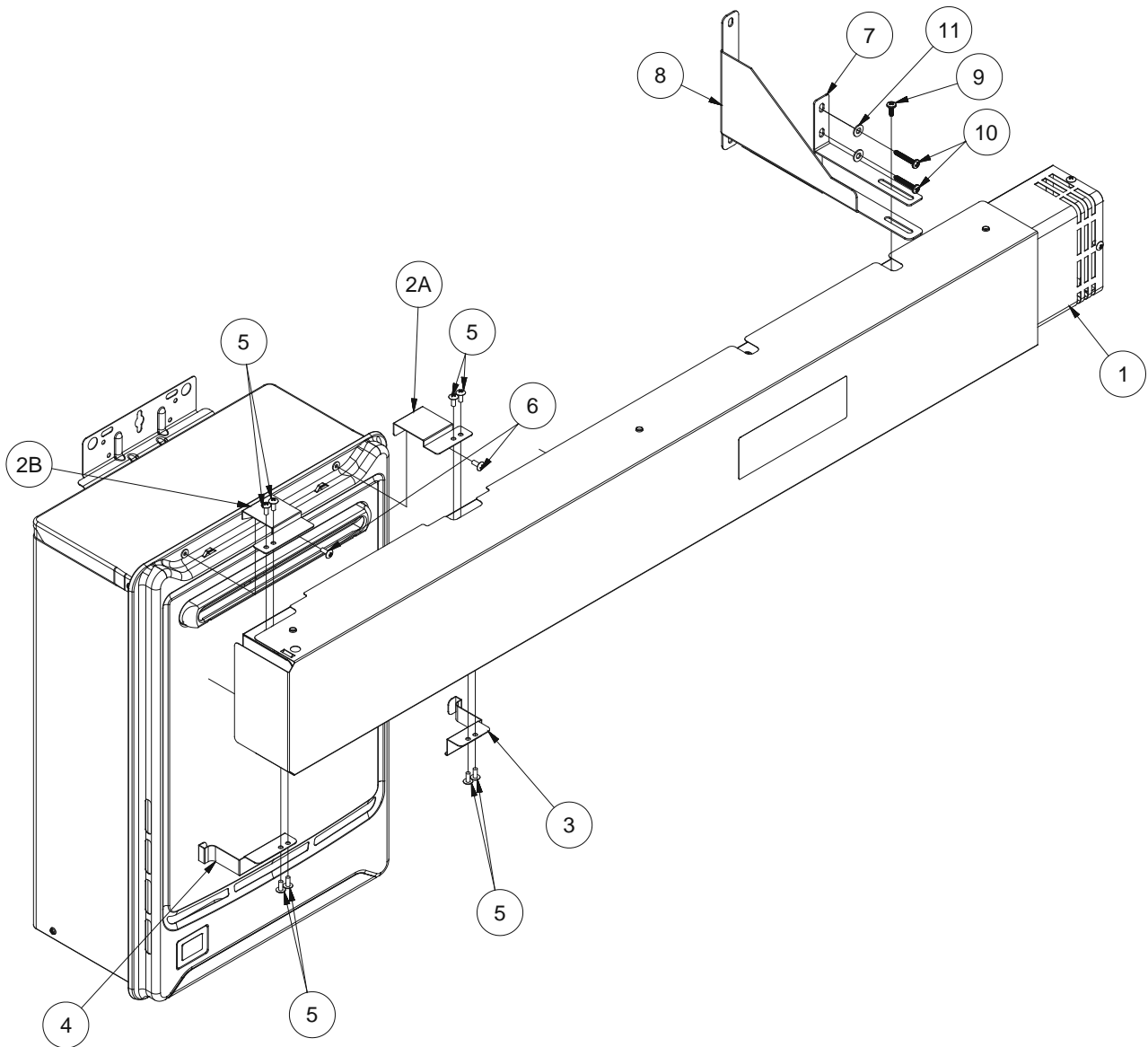

Extended Flue Terminal Diverter Details

3. Determine the correct flue terminal discharge direction, typically away from the doors and windows of the dwelling or away from balcony areas of the property. The water heater must be located to ensure that the location of the flue terminal discharge complies with the requirements of AS 5601 or AS/NZS 5601.1, as applicable under local regulations. The Diverter (1) outlet grill must not be obstructed by a building structure or fixture.
4. Remove the 2 x upper front cover screws (6) from the water heater front panel.
5. Attach the shorter upper bracket (2A) to the upper right hand side of the water heater, re-using one of the screws (6). Ensure the front panel screw (6) is tightened. Note the orientation of the bracket in the detail drawing 'Upper Bracket (2A)' of the "Upper Bracket Details" diagram. The shorter upper bracket is always installed on the right hand side of the water heater (when facing the unit).
6. Attach the longer upper bracket (2B) to the upper left hand side of the water heater, re-using one of the screws (6). Ensure the front panel screw (6) is tightened. Note the orientation of the bracket in the detail drawing 'Upper Bracket (2B)' of the "Upper Bracket Details" diagram. The longer upper bracket is always installed on the left hand side of the water heater (when facing the unit).
7. Position the Diverter over the water heater flue outlet, lining up the recesses in the top surface of the Diverter with the upper brackets (2A, 2B). Fasten the upper brackets to the top of the Diverter using two screws (5) per bracket. Tighten the screws.

-
- Position the remaining brackets (3) and (4) around the edge of the water heater front panel perimeter and align to the recesses and mounting holes in the bottom surfaces of the Diverter.

Note: bracket (4) – the longer of the two brackets, is always installed on the left hand side of the water heater (when facing the unit).

- Fasten brackets (3) and (4) to the underside of the Diverter using two screws (5) per bracket. Tighten the screws.

The Diverter assembly should now be firmly mounted over the water heater flue terminal if installed correctly.

Steps 10 to 12 apply to the installation of the Extended Flue Terminal Diverter.

- Remove the M4 x 12 mm screw (9) from the top of the Extended Flue Terminal Diverter and position either the wall mounting bracket short (7) or long (8) to the Diverter's (1) top surface. Loosely fasten the wall mounting bracket to the Diverter, reusing the M4 x 12 mm screw (9).

Note: If the water heater is installed in a recess box, the short wall mounting bracket (7) should be used for the installation. If the water heater is mounted on a wall, the long wall mounting bracket (8) should be used for the installation.

- Mark the wall bracket mounting hole positions on the wall. Secure the wall mounting bracket using two fasteners. Use the two mounting screws (10) and washers (11) with suitable plugs, only if they are suitable for the wall type. Otherwise select and use alternative fasteners suitable for the application.

Note: Refer to the fastener manufacturer's information and recommendations for the type of fastener to use for the wall type and load bearing requirements.

- Tighten the M4 x 12 mm screw (9) to secure the wall bracket to the Diverter.
- Check that all screws have been firmly tightened – DO NOT over-tighten as the screw thread can be easily stripped.

COMMISSIONING

- Switch on** the water heater at the power point and allow the unit to stabilise for 1 minute before testing its operation.
- Open a hot tap to ensure the water heater is operating correctly. Check the LED display on the front panel to identify any error codes, should the unit not operate correctly.
- Should the water heater display an error code, switch off the power and wait 5 minutes before restarting. Once restarted, allow the water heater to stabilise for 1 minute before retesting.
- If the water heater continues to display an error code, note the error code and contact **Rheem Service on 131031**.