

Owner's Operation Manual

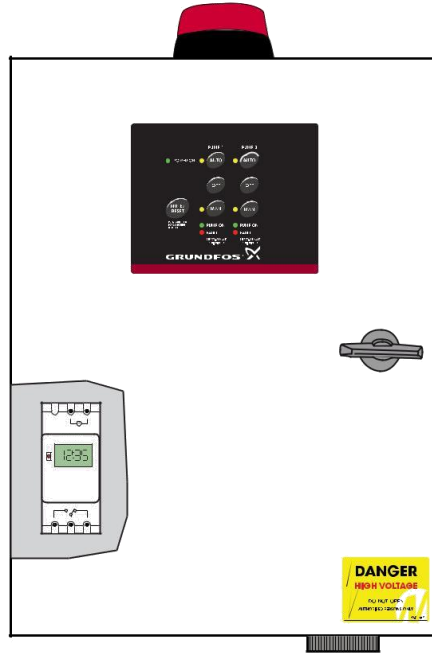

Redi-Set Dual Pump Sets Deluxe Model



*This heating unit must be installed and serviced by a qualified person.
Please leave this guide with a responsible officer.*

TABLE OF CONTENTS

SAFETY	3
CONNECTION	3
SETTING UP TIME CLOCK	5
DIMENSIONS AND TECHNICAL DATA TABLE	6
PUMP CURVE	7
OUTDOOR COVER	8
CIRCUIT DIAGRAM	9
REDI-SET DUAL PUMP SETS WARRANTY	11
1. The Rheem Warranty – General	11
2. Terms Of The Rheem Warranty And Exclusions To It	11
3. What Is Covered By The Rheem Warranty For The Products Detailed In This Document	12
4. Entitlement To Make A Claim Under This Warranty	12
5. How To Make A Claim Under This Warranty	12
6. The Australian Consumer Law	12

SAFETY

⚠ WARNING: All electrical connections must be carried out by a suitably qualified and registered electrician.

- Prior to Installation, ensure power supply is isolated.
- Power supply must be Circuit Breaker Protected. (Qualified Electrician to determine appropriate amp rating.)
- Electrical connection to the panel must be carried out in accordance with 'Connection Instructions', shown below.
- Additions or modifications to the control panel are not permitted and will void warranty.
- The controller is not intended for use by children or infirm persons without supervision.
- Repairs to the Controller must only be carried out by a suitably qualified Electrician.

CONNECTION

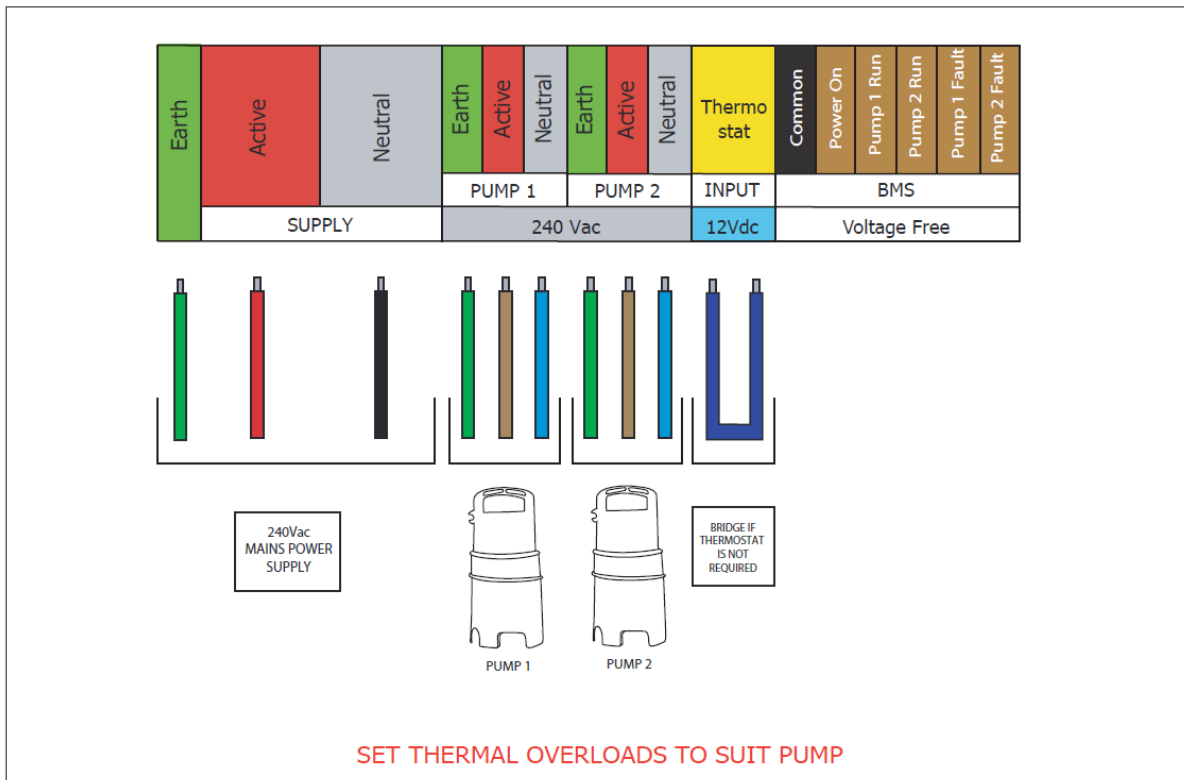

NOTE: Controller must be earthed and all electrical connections must be carried out by a suitably qualified Electrician.

Maximum Run and Alternation Mode

With **DIP Switch 3** set to "Off" the unit will alternate as usual each time a pump start condition occurs. Additionally, the controller will automatically alternate pump duty if a pump has been running continuously for 30 minutes (maximum run timer).

Setting this DIP Switch to “On” will cause the controller to operate in “Circulation Mode” where duty will only alternate once the pump has run for 6 hours of accumulated time.

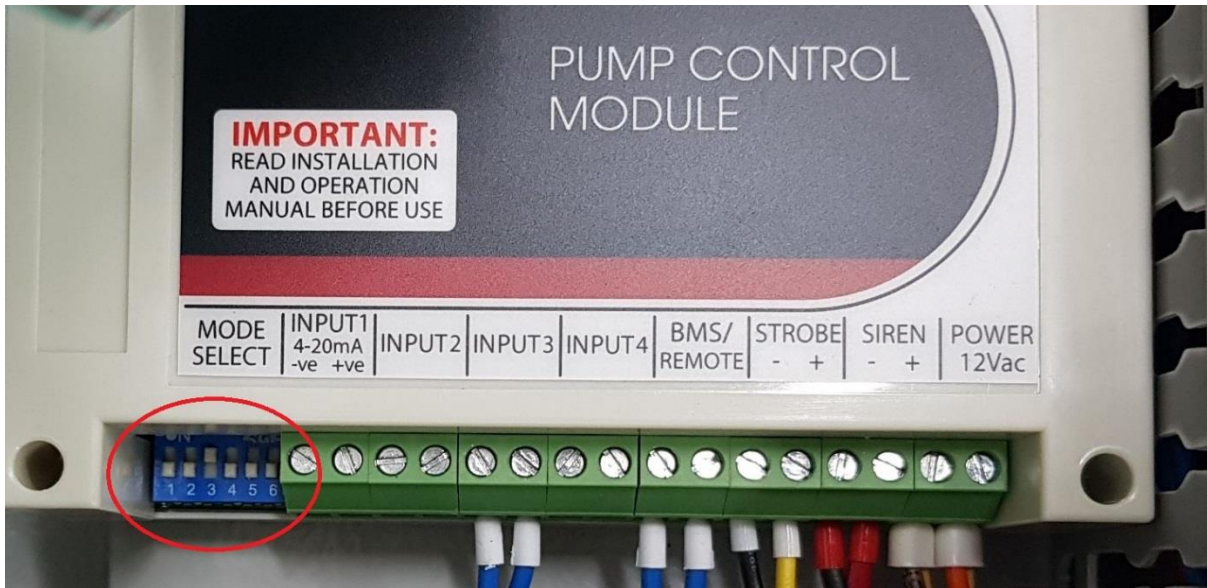

Location of the DIP Switches

Manual Mode Timeout

With **DIP Switch 5** set to “On” the pump will only remain in Manual Mode for 5 minutes, after which time, it automatically reverts to Auto.

Audible and Visual Alarm Test

By pressing the **Mute/Reset** button on the Keypad continuously for a period of 5 seconds, the Strobe, Siren and indicator Lights will be powered up for inspection.

Fault Reset

To reset all faults on the controller, press and hold the **Mute/Reset** button on the Keypad continuously for a period of 3 seconds until an acknowledgement beep is heard.

Pump Fault

A Pump Fault is indicated for two types of faults. A Thermal Overload will be indicated by way of a steady Fault Indicator Light. A Flashing pump fault indicates a prime loss. Both types of faults can be reset by way of the fault reset button.

Auto Silencing Alarm Feature

The audible Alarm is programmed to sound for 5 minutes continuously, unless muted and will thereafter automatically silence and enter “Chirp” mode. In “Chirp” mode, the Audible Alarm will sound briefly (2 seconds) every 5 minutes.

Prime Loss Protection

With **DIP Switch 1** set to ‘ON’, a flow switch is enabled for Input 1. If a pump is running for 2 minutes without the flow switch closing its contact, it will fault out the duty pump and alternate to the standby pump. The same process then occurs for the standby pump. If no flow is detected for 2 minutes it will alternate back to the previous pump.

SETTING UP TIME CLOCK

1. To start switch, press Reset key
2. To adjust the present time, please press ⌚ key, then press D+, H+, M+ to adjust the Days, Hours and Minutes.
3. Programming steps as follows:

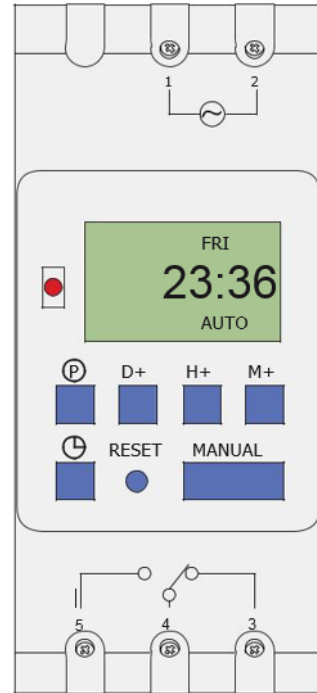

Step	Key	Programming
1	Press P	Setting 1 ON time (display 1 on)
2	Press H+/M+	Setting hours and minutes
3	Press D+	Select same every day, different day, MO-FR, MO-SA, SA-SU, MO WE FR, TU THU SA, MO-WE, TH-SA. (if same every day, no need to press this key)
4	Press P	Setting 1 OFF time (display 1 off)
5	Press H+/M+	Setting hours and minutes of the turn off time
6	Press D+	If you want the same setting every day, there is no need to press this key
7	Repeat steps 2~6	Set 2-17 ON/OFF times
8	Press ⌚	End

DIMENSIONS AND TECHNICAL DATA TABLE

Circulator Type	UPS 20-60N	UPS 32-80N
Model Number: Deluxe	99501272	99501293
Liquid Temperature Range (°C)	2-110	2-110
Max. Ambient Temperature (°C)	40	40
Max. Operating Pressure (kPa)	1000	1000
Pipe Connection (BSP)	R $\frac{3}{4}$	R1 $\frac{1}{4}$
Height x Length (mm)	990 x 340	990 x 340
Net Weight (kg)	27	33
Electrical Rating	240V/50Hz	240V/50Hz
Pump Housing	Stainless Steel	Stainless Steel
Impeller	Composite, PES/PP	Composite, PES/PP
IP Rating of Pumps	IP44	IP44
IP Rating of Control Panels	IP54	IP54

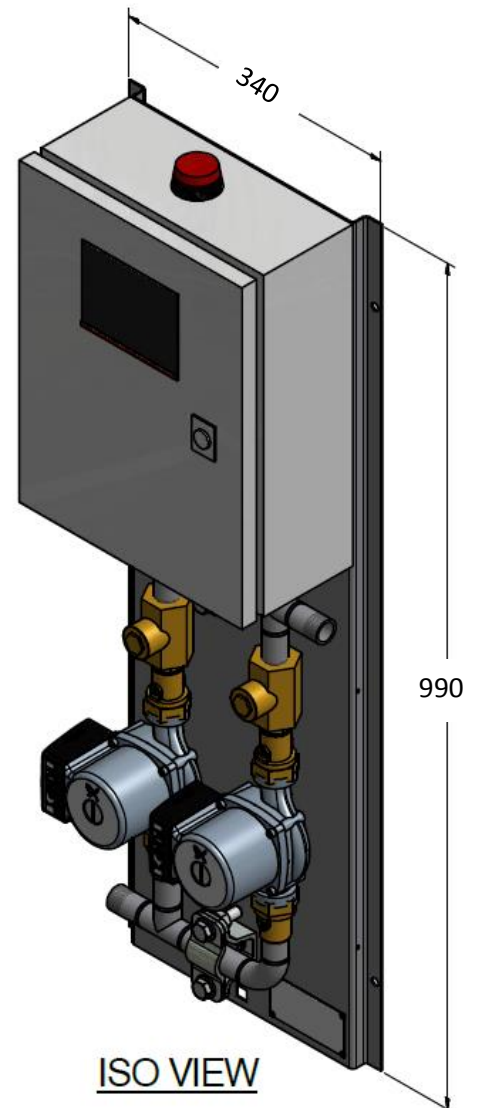

PUMP CURVE

UPS 20-60N

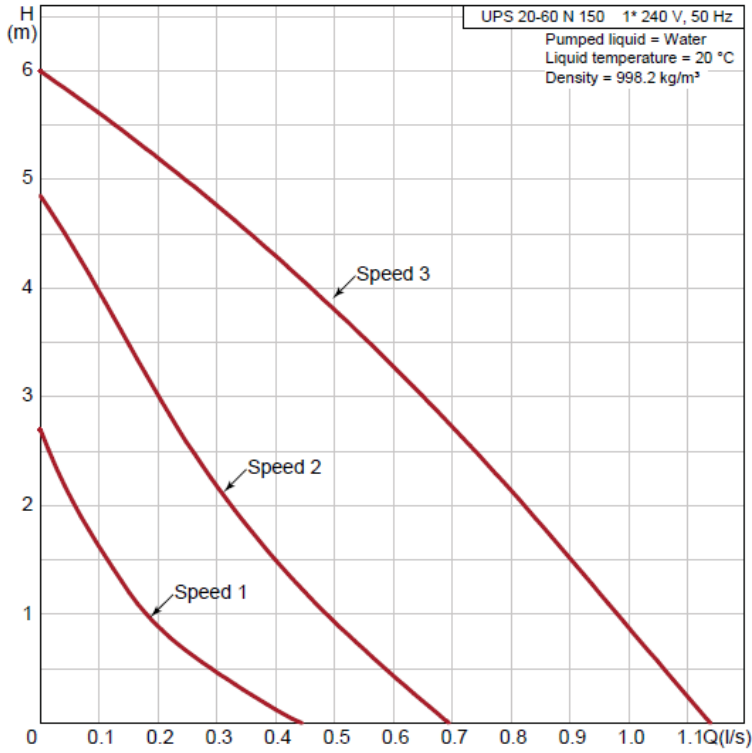

UPS 32-80N

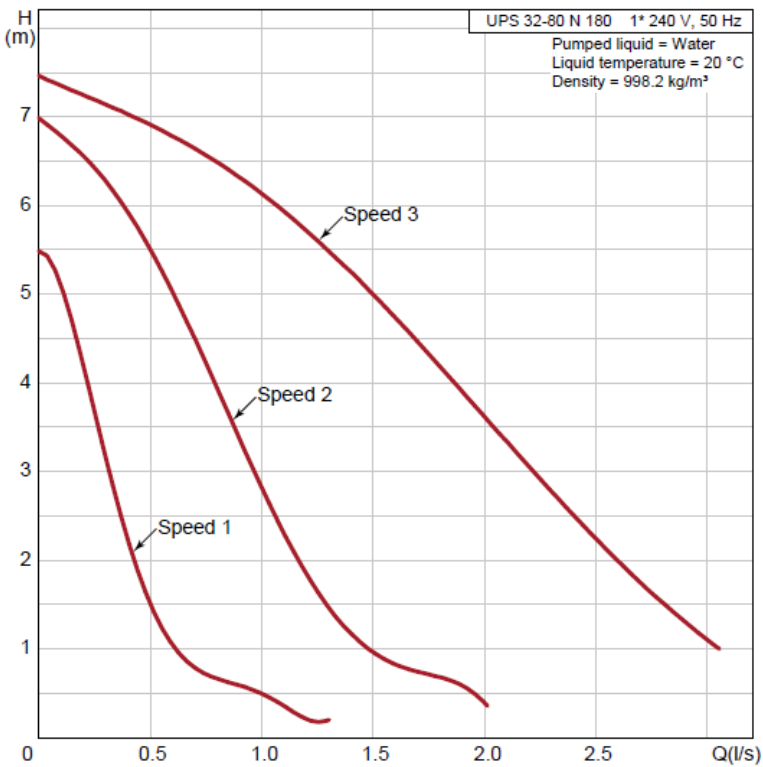

OUTDOOR COVER

Redi-Set pumps can be installed outdoor by installing outdoor covers supplied by Rheem. The part number for the outdoor cover is AQ2051057.

It includes two self-tapping screws (8 gauge x 10mm) for attaching the cover with the Redi-Set pump.

The outdoor cover needs to be placed properly over the pump sets. A marker should be used to mark two spots for drilling two pilot holes into the base plate of the Redi-set pumps aligning with the two holes on the cover. After removing the cover, 2x 3mm pilot holes need to be drilled.

Place the outdoor cover according to the pilot holes and use 2x self-tapping screws (supplied) to attach the cover with the Redi-Set pumps.

Note: The outdoor cover must be ordered separately for outdoor installation.

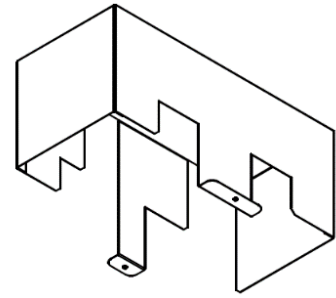

CIRCUIT DIAGRAM

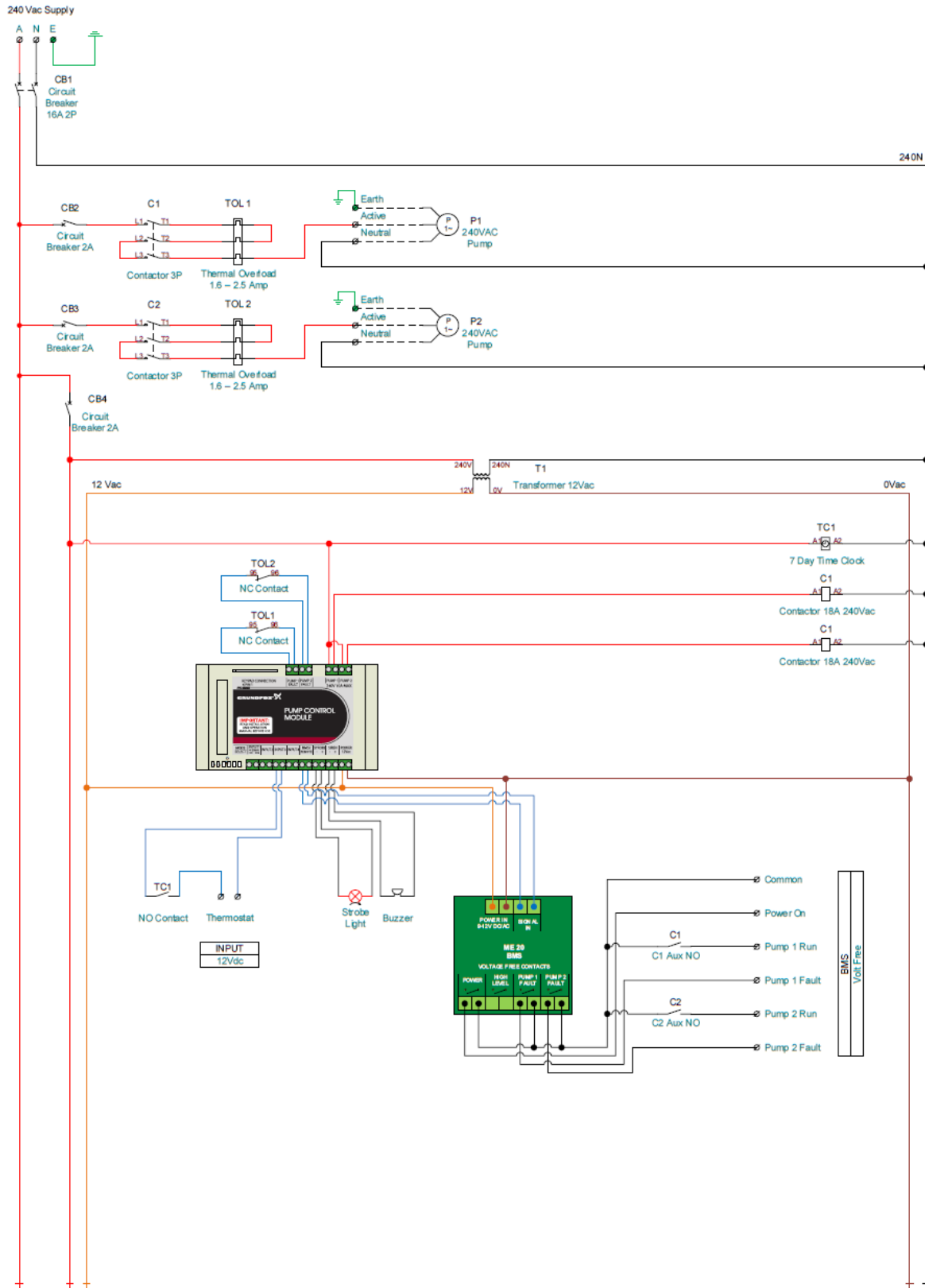

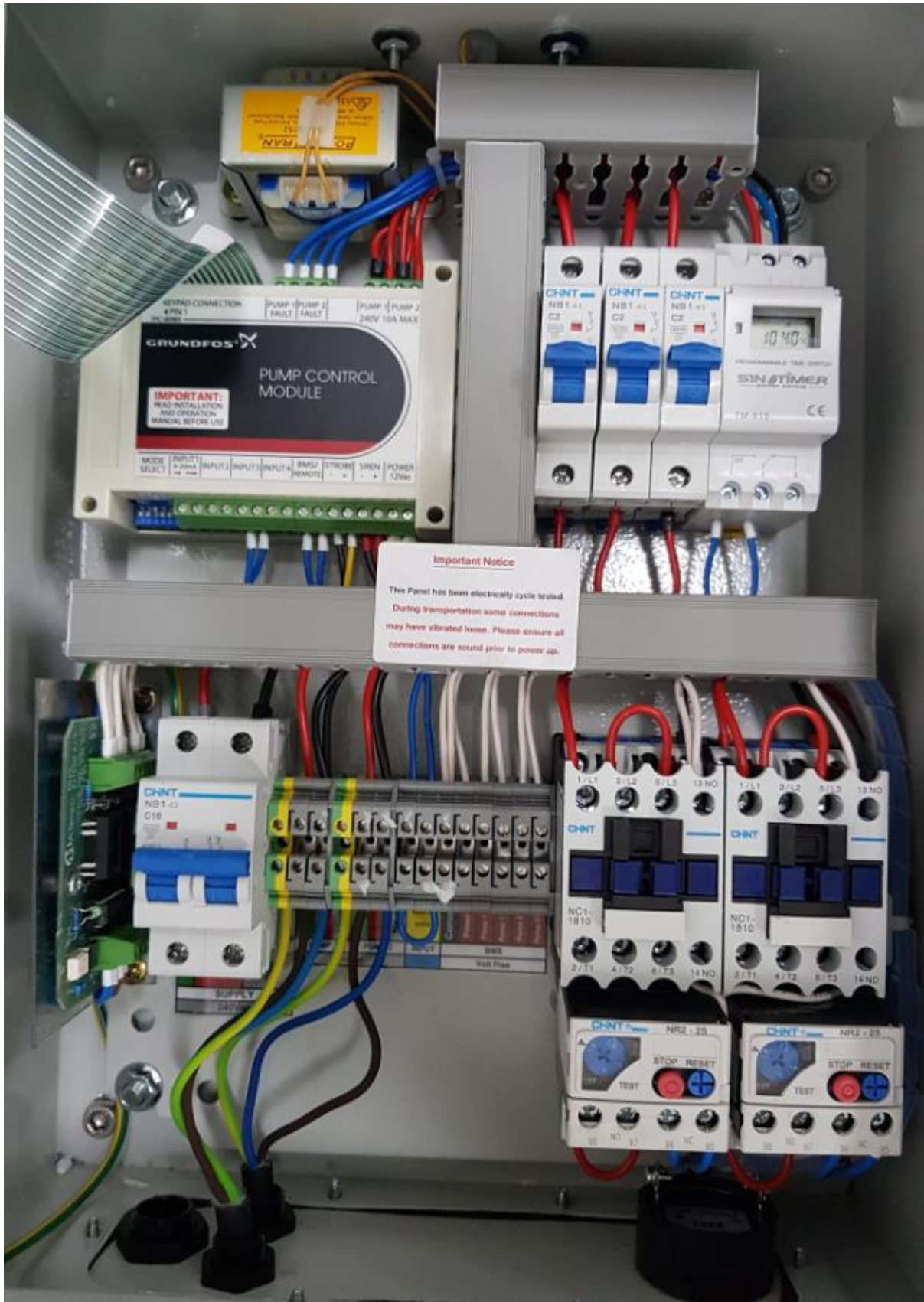

REDI-SET DUAL PUMP SETS WARRANTY

REDI-SET DUAL PUMP SETS MODELS 99501272 AND 99501293

1. THE RHEEM WARRANTY – GENERAL

- 1.1 This warranty is given by Rheem Australia Pty Limited ABN 21 098 823 511 of 1 Alan Street, Rydalmere New South Wales.
- 1.2 Rheem offer a trained and qualified national service network who will repair or replace components at the address of the product subject to the terms of the Rheem warranty. Rheem Service, in addition can provide preventative maintenance and advice on the operation of your product. The Rheem Service contact number is available 7 days a week on 131031 with Service personnel available to take your call from 8am to 8pm daily (hours subject to change).
- 1.3 For details about this warranty, you can contact us on 131031 or by email at warrantyenquiry@rheem.com.au (not for service bookings).
- 1.4 The terms of this warranty and what is covered by it are set out in sections 2 and 3 and apply to products manufactured after 1st December 2015.
- 1.5 If a subsequent version of this warranty is published, the terms of that warranty and what is covered by it will apply to products manufactured after the date specified in the subsequent version.

2. TERMS OF THE RHEEM WARRANTY AND EXCLUSIONS TO IT

- 2.1 The decision of whether to repair or replace a faulty component is at Rheem's sole discretion.
- 2.2 If you require a call out and we find that the fault is not covered by the Rheem warranty, you are responsible for our standard call out charge. If you wish to have the relevant component repaired or replaced by Rheem, that service will be at your cost.
- 2.3 Where a failed component or cylinder is replaced under this warranty, the balance of the original warranty period will remain effective. The replacement does not carry a new Rheem warranty.
- 2.4 Where the product is installed outside the boundaries of a metropolitan area as defined by Rheem or further than 25 km from either a regional Rheem branch office or an Accredited Rheem Service Agent's office, the cost of transport, insurance and travelling between the nearest branch office or Rheem Accredited Service Agent's office and the installed site shall be the owner's responsibility.
- 2.5 Where the product is installed in a position that does not allow safe or ready access, the cost of that access, including the cost of additional materials handling and/or safety equipment, shall be the owner's responsibility. In other words, the cost of dismantling or removing cupboards, doors or walls and the cost of any special equipment to bring the product to floor or ground level or to a serviceable position is not covered by this warranty.
- 2.6 This warranty only applies to the original and genuine Rheem product in its original installed location and any genuine Rheem replacement parts.
- 2.7 The Rheem warranty does not cover faults that are a result of:
 - a) Accidental damage to the product or any component (for example: (i) Acts of God such as floods, storms, fires, lightning strikes and the like; and (ii) third party acts or omissions).
 - b) Misuse or abnormal use of the product.
 - c) Installation not in accordance with the Owner's Guide and Installation Instructions or with relevant statutory and local requirements in the State or Territory in which the product is installed.
 - d) Connection at any time to a water supply that does not comply with the water supply guidelines as outlined in the Owner's Guide and Installation Instructions.
 - e) Repairs, attempts to repair or modifications to the product by a person other than Rheem Service or a Rheem Accredited Service Agent.
 - f) Faulty plumbing or faulty power supply.
 - g) Failure to maintain the product in accordance with the Owner's Guide and Installation Instructions.
 - h) Transport damage.
 - i) Fair wear and tear from adverse conditions (for example, corrosion).
 - j) Cosmetic defects.
- 2.8 Subject to any statutory provisions to the contrary, this warranty excludes any and all claims for damage to furniture, carpet, walls, foundations or any other consequential loss either directly or indirectly due to leakage from the product, or due to leakage from fittings and/ or pipe work of metal, plastic or other materials caused by water temperature, workmanship or other modes of failure.
- 2.9 If the product is not sized to supply the hot water demand in accordance with the guidelines in the Rheem product literature, any resultant fault will not be covered by the Rheem warranty.

REDI-SET DUAL PUMP SETS MODELS 99501272 AND 99501293

3. WHAT IS COVERED BY THE RHEEM WARRANTY FOR THE REDI-SET PUMP SETS DETAILED IN THIS DOCUMENT

- 3.1 Rheem will repair or replace a faulty component of your product if it fails to operate in accordance with its specifications as follows:

What components are covered	The period from the date of installation in which the fault must appear in order to be covered	What coverage you receive
All components	Year 1	Repair and/or replacement of the faulty component, free of charge, including labour.

4. ENTITLEMENT TO MAKE A CLAIM UNDER THIS WARRANTY

- 4.1 To be entitled to make a claim under this warranty you need to:
- Be the owner of the product or have consent of the owner to act on their behalf.
 - Contact Rheem Service without undue delay after detection of the defect and, in any event, within the applicable warranty period.
- 4.2 You are **not** entitled to make a claim under this warranty if your product:
- Does not have its original serial numbers or rating labels.
 - Is not installed in Australia.

5. HOW TO MAKE A CLAIM UNDER THIS WARRANTY

- 5.1 If you wish to make a claim under this warranty, you need to:
- Contact Rheem on 131031 and provide owner's details, address of the product, a contact number and date of installation of the product or if that's unavailable, the date of manufacture and serial number (from the rating label on the product).
 - Rheem will arrange for the product to be tested and assessed on-site.
 - If Rheem determines that you have a valid warranty claim, Rheem will repair or replace the product in accordance with this warranty.
- 5.2 Any expenses incurred in the making of a claim under this warranty will be borne by you.

6. THE AUSTRALIAN CONSUMER LAW

- 6.1 Our goods come with guarantees that cannot be excluded under the *Australian Consumer Law*. You are entitled to a replacement or refund for a major failure and for compensation for any other reasonably foreseeable loss or damage. You are also entitled to have the goods repaired or replaced if the goods fail to be of acceptable quality and the failure does not amount to a major failure.
- 6.2 The Rheem warranty (set out above) is in addition to any rights and remedies that you may have under the *Australian Consumer Law*.

RHEEM AUSTRALIA PTY LTD, A.B.N. 21 098 823 511
www.rheem.com.au
For Service Telephone 131 031 AUSTRALIA or 0800 657 335 NEW ZEALAND