

RAYPAK® ATMOSPHERIC HEATING AND HOT WATER

The industrial duty hot water system providing extreme durability.

CASE STUDY

CROWN CASINO SYDNEY, NSW

Challenge

Sydney's Crown Casino at Barangaroo offers the ultimate in premium luxury facilities. The large hot water requirement is served by six separate zones, with each plantroom having their own unique temperature requirements and constraints.

Hot water solution

Multiple compact plant rooms each providing centralised hot water to separate zones in the building.

The combined plant includes:

- 4 x Raypak B3694 gas water heaters
- 2 x Raypak B4224 gas water heaters
- 2 x Raypak B1722 gas water heaters
- 2 x Raypak B0868 gas water heaters
- 2 x Raypak B0538 gas water heaters
- 2 x Rheem Tankpak TPI05NFD gas water heaters
- 7 x RT2000 stainless steel storage tanks
- 1 x RT1000 stainless steel storage tank
- 2 x Rheem 610430 storage tanks
- 7 x Guardian 940240 warm water units



RAYPAK® ATMOSPHERIC

FOR DOMESTIC HOT WATER AND HYDRONIC APPLICATIONS



GAS



IN MARKET



ROBUST CONSTRUCTION



FAST REPLACEMENT



THERMAL EFFICIENCY

Raypak® is a compact, efficient heating design which is the ideal way to heat large quantities of water for both hot water and hydronic applications.

HIGHLY RELIABLE

In the market for 50 years, Raypak's direct fired, bronze headers and pure copper-finned heat exchangers resist the combined effects of corrosion and high temperature.

CONSTANT HOT WATER AND HYDRONIC HEATING

Operating on mains pressure, on/off models deliver constant full recovery and modulating models respond to building load in low pressure heating circuits. On/Off models can operate as low as 41°C without any condensation or sooting.

FAST REPLACEMENT

The atmospheric combustion system and slide-out burner tray make it simple to maintain and repair, and the unit is readily deconstructed on site to allow for retrofit access.

HIGHLY EFFICIENT

Raypak's copper tube construction is highly responsive with an outstanding 82% thermal efficiency. The ceramic fibre refractory panels insulate the system with an interlocking design reducing heat loss. Add to this, high MJ/m² allowing for space saving installation flexibility.



WITHSTANDS HIGH TEMPERATURES

Robust materials mean modulating units can provide up to 90°C, ideal for sanitising and industrial process applications.

BMS CONNECTIVITY

Run and fail monitoring (available on Type B models).

MORE KEY FEATURES

- Selected models are available in propane
- Left hand(normal) or right hand water and gas connections available
- Water flow switch (Type B models)
- Heaters can be plumbed together for redundancy
- On/Off models suitable for domestic hot water applications
- Modulating models suitable for hydronic applications



* Conditions apply: For full terms and conditions please contact Rheem or see Owner's Guide and Installation Instructions, available at www.rheem.com.au

TECHNICAL DATA

RAYPAK PIPE SIZE AND PUMP SELECTION CHART

Model	Pump UPS Series	Phase	Branch Size	Minimum Manifold Header Size/Pump Speed Required (mm)			
				1 Unit	2 Units	3 Units	4 Units
280	32-80N	1	32mm	32/3	32/3	50/3	65/3
350	32-80N	1	40mm	40/3	50/3	65/3	65/3
430	32-80N	1	40mm	40/3	50/3	65/3	80/3
538	32-80N	1	50mm	50/3	65/3	80/3	100/3
658	32-80N	1	50mm	50/3	80/3	80/3	100/3
768	40-60/2B	1	50mm	50/2	80/2	100/2	100/2
868	40-60/2B	1	65mm	65/2	80/2	100/2	100/3
972 / 992	40-60/2B	1	65mm	65/3	80/3	100/3	125/3
1142 / 1182	50-120FB	1	65mm	65/1	100/1	100/1	125/1
1242 / 1292	50-120FB	1	65mm	65/1	100/2	125/2	125/2
1362 / 1412	50-120FB	1	65mm	65/1	100/2	125/2	125/1
1662 / 1722	50-120FB	1	80mm	80/3	100/3	125/3	150/3
1852 / 1922	50-120FB	1	80mm	80/3	100/3	125/3	150/3
2004 / 2214	50-120FB	1	100mm	100/3	125/3	150/3	200/3
2404	50-120FB	1	100mm	100/3	125/3	150/3	200/3
2634	50-120FB	1	100mm	100/3	125/3	200/3	200/3
2804	65-150 FN	1	100mm	100/PP1	150 /PP1	200/PP1	200/PP1
3164	65-150 FN	1	100mm	100/PP1	150/PP1	200/PP1	200/PP1
3304	65-150 FN	1	100mm	125/PP1	150/PP1	200/PP1	200/PP1
3694	65-150 FN	1	125mm	125/PP1	200/PP1	200/PP1	-
3804	65-150 FN	1	125mm	125/PP1	200/PP1	200/PP2	-
4224	65-150 FN	1	125mm	125/PP1	200/PP1	-	-

NOTE: TP series circulator is recommended for hard water areas in lieu of UPS series circulator. Contact Rheem for further information.

Manifold header sizes are minimum requirements for water heater performance.

Pipe and pump sizing is for DHW only system up to 65°C maximum set point. Header pipe sizing is based on a total length of 20m of primary flow and return piping and 20 elbows, excluding equa-flow manifolds on storage tanks and Raypaks at 1.2m/sec velocity.

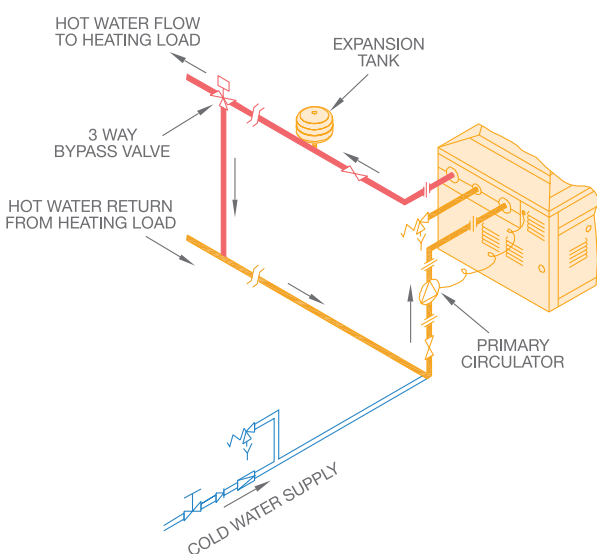

Single Mechanical Heating System

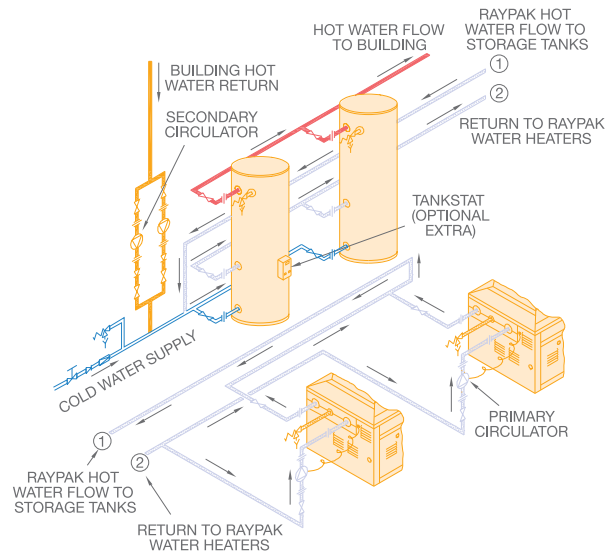

Double Domestic Hot Water System

TECHNICAL DATA

DIMENSIONS AND TECHNICAL DATA TABLE – INDOOR/OUTDOOR MODELS

Model		200	280	350	430	538	658	768	868
Natural – Input	MJ/h	196	278	343	420	539	661	765	870
	kW	44	62	76	94	120	150	170	195
Propane – Input	MJ/h	185	261	323	396	–	620	–	–
	kW	41	58	72	88	–	140	–	–
Dimensions									
A	mm	1,625	1,715	1,715	1,805	–	–	–	–
B	mm	465	570	655	745	830	955	1,055	1,160
C	mm	1,955	2,240	2,035	2,145	2,130	2,255	2,255	2,355
Flue Connection	mm	175	205	225	255	255	305	305	355
Weight	kg	91	93	103	107	195	200	250	260
Inlet/Outlet Connections		RC1½	RC1½	RC1½	RC1½	RC2½	RC2½	RC2½	RC2½
Gas Connection									
Natural – On / Off Models		NA	RP¾	RP¾	RP¾	R1	R1½	R1½	R1½
Natural – Modulating Models		RP1	RP1	RP1	RP1	R1	R1	R1½	R1½
Propane – On / Off Models		NA	RP¾	RP¾	RP¾	–	–	–	–
Propane – Modulating Models		RP¾	RP¾	RP¾	RP¾	–	R¾	–	–
Relief Valve Connection									
On/Off models		NA	RC¾	RC¾	RC¾	RC¾	RC¾	RC¾	RC¾
Modulating models		RC¾	RC¾	RC¾	RC¾	RC¾	RC¾	RC¾	RC¾
Electrical Rating 240V 50Hz (excluding pump)	Watts	50	50	50	50	50	50	50	50
	Amps	0.21	0.21	0.21	0.21	0.21	0.21	0.21	0.21
Min. Buffer Tank Capacity	Litres	325	325	325	325	325	325	325	325
Max. Storage Capacity	Litres	2,000	3,000	4,000	4,800	6,000	7,500	8,500	10,000
Natural Gas									
Litres Recovery Per Hour @	30°C rise	1,250	1,769	2,187	2,683	3,440	4,300	4,873	5,590
	40°C rise	937	1,327	1,640	2,012	2,580	3,225	3,655	4,193
	50°C rise	750	1,061	1,312	1,610	2,064	2,580	2,924	3,354
	60°C rise	625	884	1,094	1,342	1,720	2,150	2,437	2,795
	65°C rise	577	816	1,010	1,238	1,588	1,985	2,249	2,580
	70°C rise	536	758	937	1,150	1,474	1,843	2,089	2,396
	75°C rise	500	708	875	1,073	1,376	1,720	1,949	2,236
	80°C rise	469	663	820	1,006	1,290	1,613	1,828	2,096
85°C rise	441	624	772	947	1,214	1,518	1,720	1,973	
Flow Rate and Pressure Drop									
Max. Flow Rate									
Modulating (10°C Rise) ¹	L/s	1.04	1.47	1.82	2.24	2.87	3.58	4.06	4.66
Pressure Drop	kPa	3	8	13	17	6	10	14	22
Max. Flow Rate									
On/Off (15°C Rise) ¹	L/s	0.69	0.98	1.22	1.49	1.91	2.39	2.71	3.11
Pressure Drop	kPa	3	4	6	8	3	4	6	8
Min. Flow Rate									
(20°C rise) ¹	L/s	0.52	0.74	0.91	1.12	1.43	1.79	2.03	2.33
Pressure Drop	kPa	3	3	3	4	3	3	4	5

¹ Guide only.

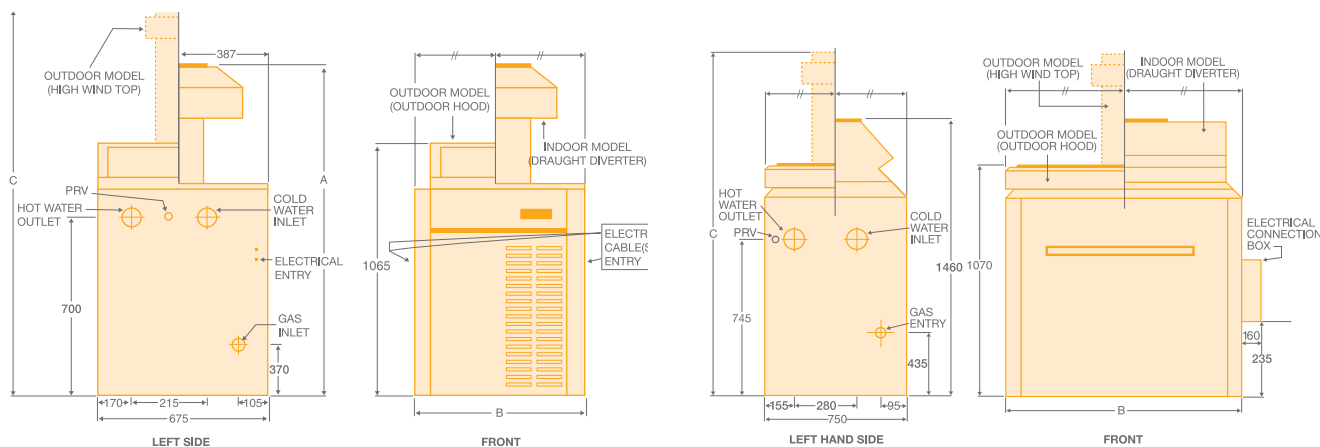

Models 200, 280, 350, 430 (Indoor/Outdoor)

Models 538, 658, 768 and 868 (Indoor/Outdoor)

TECHNICAL DATA

DIMENSIONS AND TECHNICAL DATA TABLE – INDOOR MODELS												
Model		992	1182	1292	1412	1722	1922	2214	2634	3164	3694	4224
Natural – Input	MJ/h	999	1,186	1,289	1,412	1,719	1,926	2,215	2,636	3,165	3,692	4,224
	– Output	kW	225	265	285	315	380	430	505	600	720	840
Propane – Input		933	–	–	1,296	–	1,772	–	–	–	–	–
	– Output		205	–	–	290	–	395	–	–	–	–
Dimensions												
A	mm	1,810	1,915	1,915	1,990	2,060	2,130	–	–	–	–	–
B	mm	1,330	1,510	1,615	1,740	2,070	2,270	1,550	1,780	2,060	2,350	2,640
G	mm	860	860	860	860	930	930	–	–	–	–	–
Flue Connection	mm	355	405	405	455	455	505	610	660	710	760	815
Weight	kg	310	330	360	390	440	460	625	700	780	860	940
Inlet/Outlet Connections		RC2½	RC2½	RC2½	RC2½	RC2½	RC2½	RC3	RC3	RC3	RC3	RC3
Gas Connection												
Natural – On / Off Models		R1½	R1½	R1½	R1½	R2	R2	R2	R2½	R2½	R3	R3
Natural – Modulating Models		R1½	R1½	R1½	R1½	R2	R2	R2	R2½	R2½	R3	R3
Propane – Modulating Models		R¾			R1		R1½					
Relief Valve Connection												
On/Off Models		RC¾	RC¾	RC¾	RC¾	RC¾	RC¾	RC¾	RC¾	RC1	RC1	RC1
Modulating Models		RC¾	RC¾	RC¾	RC¾	RC1	RC1	RC1¼	RC1¼	RC1½	RC1½	RC1½
Electrical Rating 240V 50Hz (excluding pump)	Watts	100	100	100	100	100	100	100	100	100	100	100
	Amps	0.42	0.42	0.42	0.42	0.42	0.42	0.42	0.42	0.42	0.42	0.42
Min. Buffer Tank Capacity	Litres	387	456	490	542	654	740	869	824	990	1,156	1,320
Max. Storage Capacity	Litres	11,000	13,000	14,500	16,000	19,500	22,000	27,000	31,000	37,000	43,500	49,500
Natural Gas												
Litres Recovery Per Hour @	30°C rise	6,450	7,597	8,170	9,030	10,893	12,327	14,477	17,200	20,640	24,080	27,520
	40°C rise	4,838	5,698	6,128	6,773	8,170	9,245	10,858	12,900	15,480	18,060	20,640
	50°C rise	3,870	4,558	4,902	5,418	6,536	7,396	8,686	10,320	12,384	14,448	16,512
	60°C rise	3,225	3,798	4,085	4,515	5,447	6,163	7,238	8,600	10,320	12,040	13,760
	65°C rise	2,977	3,506	3,771	4,168	5,028	5,689	6,682	7,939	9,526	11,114	12,702
	70°C rise	2,764	3,256	3,501	3,870	4,669	5,283	6,204	7,372	8,846	10,320	11,794
	75°C rise	2,580	3,039	3,268	3,612	4,357	4,931	5,791	6,880	8,256	9,632	11,008
	80°C rise	2,419	2,849	3,064	3,386	4,085	4,623	5,429	6,450	7,740	9,030	10,320
85°C rise	2,276	2,681	2,884	3,187	3,845	4,351	5,109	6,071	7,285	8,499	9,713	
Flow Rate and Pressure Drop												
Max. Flow Rate												
Modulating (10°C rise) ¹	L/s	5.38	6.31	6.31	6.31	6.31	6.31	12.06	12.62	12.62	12.62	12.62
Pressure Drop	kPa	29	44	46	49	55	58	48	49	50	54	57
Max. Flow Rate												
On/Off (15°C rise) ¹	L/s	3.58	4.22	4.54	5.02	6.05	6.31	8.04	9.56	11.47	12.62	12.62
Pressure Drop	kPa	12	18	24	30	51	58	20	28	38	54	57
Min. Flow Rate												
(20°C rise) ¹	L/s	2.69	3.17	3.40	3.76	4.54	5.14	6.03	7.17	8.60	10.03	11.47
Pressure Drop	kPa	7	11	14	18	30	39	12	17	23	30	42

¹ Guide only.

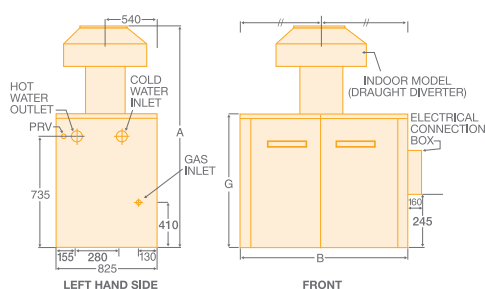

Models 992, 1182, 1292, 1412, 1722, 1922 (Indoor)

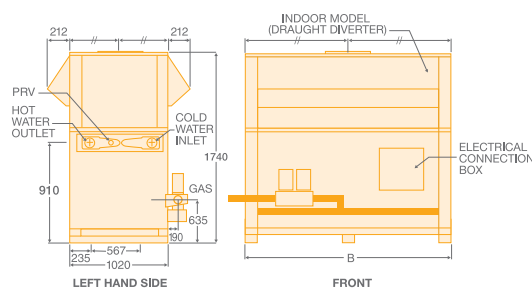

Models 2214, 2634, 3164, 3694, 4224 (Indoor)

TECHNICAL DATA

DIMENSIONS AND TECHNICAL DATA TABLE – OUTDOOR MODELS

Model		972	1142	1242	1362	1662	1852	2004	2404	2804	3304	3804
Natural – Input	MJ/h	976	1,142	1,242	1,357	1,657	1,854	2,004	2,404	2,804	3,304	3,804
	– Output	kW	220	255	275	300	370	410	445	530	625	740
Dimensions												
A	mm	2,500	2,395	2,395	2,570	2,640	2,920	3,165	3,210	3,185	2,965	3,165
B	mm	1,330	1,510	1,615	1,740	2,070	2,270	1,550	1,780	2,060	2,350	2,635
Weight	kg	360	385	410	440	510	520	650	730	810	890	970
Inlet/Outlet Connections		RC2½	RC2½	RC2½	RC2½	RC2½	RC2½	RC3	RC3	RC3	RC3	RC3
Gas Connection												
Natural – On / Off Models		R1½	R1½	R1½	R1½	R2	R2	R2	RC2½	RC2½	RC2½	R3
Natural – Modulating Models		R1½	R1½	R1½	R1½	R2	R2	R2	RC2½	RC2½	R3	R3
Propane – Modulating Models		R¾			R1		R1½					
Relief Valve Connection												
On/Off models		RC¾	RC¾	RC¾	RC¾	RC¾	RC¾	RC¾	RC¾	RC1	RC1	RC1
Modulating models		RC¾	RC¾	RC¾	RC¾	RC1	RC1	RC1½	RC1½	RC1½	RC1½	RC1½
Electrical Rating 240V 50Hz (excluding pump)	Watts	100	100	100	100	100	100	100	100	100	100	100
	Amps	0.42	0.42	0.42	0.42	0.42	0.42	0.42	0.42	0.42	0.42	0.42
Min. Buffer Tank Capacity	Litres	378	439	473	516	636	705	765	729	860	1,018	1,163
Max. Storage Capacity	Litres	11,000	13,000	14,000	15,500	19,000	21,000	23,000	27,000	32,000	39,000	43,000
Natural Gas												
Litres Recovery Per Hour @	30°C rise	6,307	7,310	7,883	8,600	10,607	11,753	12,757	15,194	17,917	21,214	24,224
	40°C rise	4,730	5,483	5,913	6,450	7,955	8,815	9,568	11,395	13,438	15,910	18,168
	50°C rise	3,784	4,386	4,730	5,160	6,364	7,052	7,654	9,116	10,750	12,728	14,534
	60°C rise	3,153	3,655	3,942	4,300	5,303	5,877	6,378	7,597	8,958	10,607	12,112
	65°C rise	2,911	3,374	3,639	3,969	4,895	5,425	5,888	7,012	8,269	9,791	11,180
	70°C rise	2,703	3,133	3,379	3,686	4,546	5,037	5,467	6,512	7,679	9,092	10,382
	75°C rise	2,523	2,924	3,153	3,440	4,243	4,701	5,103	6,077	7,167	8,485	9,689
	80°C rise	2,365	2,741	2,956	3,225	3,978	4,408	4,784	5,698	6,719	7,955	9,084
85°C rise	2,226	2,580	2,782	3,035	3,744	4,148	4,502	5,362	6,324	7,487	8,550	
Flow Rate and Pressure Drop												
Max. Flow Rate												
Modulating (10°C Rise) ¹	L/s	5.26	6.09	6.31	6.31	6.31	6.31	10.63	12.62	12.62	12.62	12.62
Pressure Drop	kPa	27	43	46	49	55	58	45	49	53	57	60
Max. Flow Rate												
On/Off (15°C Rise) ¹	L/s	3.50	4.06	4.38	4.78	5.89	6.31	7.09	8.44	9.95	11.79	12.62
Pressure Drop	kPa	12	18	23	30	49	58	18	28	35	53	57
Min. Flow Rate												
(20°C rise) ¹	L/s	2.63	3.05	3.28	3.58	4.42	4.90	5.32	6.33	7.47	8.84	10.09
Pressure Drop	kPa	7	10	12	16	27	21	12	17	21	30	42

¹ Guide only.

² Two high wind tops per model.

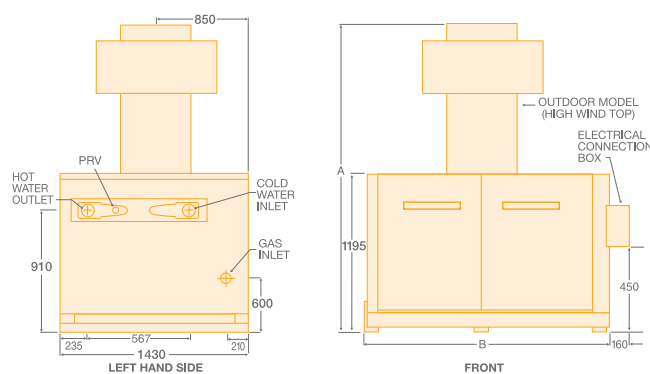
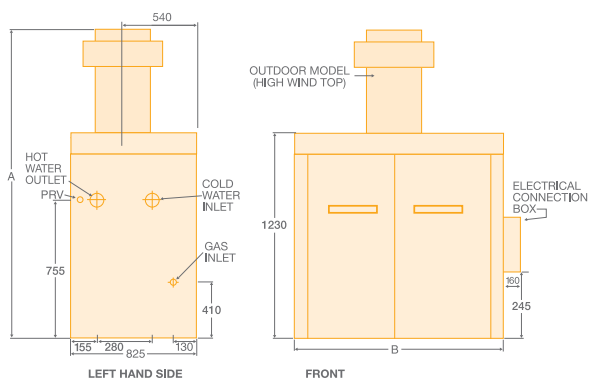

Models 972, 1142, 1242, 1362, 1662, 1852 (Outdoor)

Models 2004, 2404, 2804², 3304², 3804² (Outdoor)

TECHNICAL DATA

ACCESSORIES FOR RAYPAK COMMERCIAL GAS WATER HEATERS

Accessories	Standard	Optional
Pump Run on Timer	All modulating	All On/Off
Tankstat	–	200 to 4224
Hot Surface Ignition (HSI)	200 to 430	–
Electronic Ignition	538 to 4224	–
Water Flow Switch	538 to 4224	–
Relay Run and Fault Status	538 to 4224	–
High Wind Top (outdoor installations only)	538 to 3804	200 to 430
Left Hand Water and Gas Connections	200 to 4224	–
Right Hand Water Connections	–	200 to 430
Right Hand Water and Gas Connections	–	538 to 4224

MINIMUM SUPPLY PRESSURE

System design and pump selection is critical when water heaters are connected to a low pressure water supply. Refer to the table below for minimum pressure requirements for Grundfos UPS series pumps. Minimum pressure requirements for TP series pumps depend on system characteristics and need to be calculated. Contact your pump supplier for details.

Pump	Model	Minimum Inlet Pressure Required (m) at Operating Temperature				
		75°C	80°C	85°C	90°C	95°C
UPS32-80N	280, 350, 430, 538, 658	0.5	0.5	0.5	3.0	5.0
UPS40-60/2B	768, 868, 972, 992	1.5	2.5	3.5	4.5	7.0
UPS50-120FB	1142, 1182, 1242, 1292, 1362, 1412, 1662, 1722, 1852, 1922, 2004, 2214, 2404, 2634	4.0	5.0	6.0	7.0	9.0
Magna1 65-150	2804, 3164, 3304, 3694, 3804, 4224	8	9	10	11.5	13

WATER SUPPLY AND RELIEF VALVE SETTINGS

Burner Type		On/Off	Modulating	
Models		All	200–430	538–4224
Relief Valve Setting				
Potable Hot Water	kPa	850	850 ⁵	850 ⁵
Mechanical Heating	kPa	–	310	415
Expansion Control Valve (ECV ⁴) Setting				
Potable Hot Water	kPa	700	700 ⁵	700 ⁵
Mechanical Heating	kPa	–	–	–
Maximum Supply Pressure without ECV ⁴ fitted				
Potable Hot Water	kPa	680	680 ⁵	680 ⁵
Mechanical Heating	kPa	–	240	330
with ECV ⁴ fitted				
Potable Hot Water	kPa	550	550 ⁵	550 ⁵
Mechanical Heating	kPa	–	–	–



Raypak® indoor gas water heaters are designed for connection to a flue system in accordance with the requirements of AS/NZS 5601.1.

TECHNICAL DATA

RAYPAK MODEL NUMBERS

The following information should be supplied when ordering Raypak water heaters

B	0430	N	C	O	/	ID
Water	Approx	N = Natural Gas	Copper Heat	O = On/Off		ID = Indoor
Heater	Thermal Input*	P = Propane	Exchanger	M = Modulating		HWT = High Wind Top

NOTE: *last digit designates series type.

GAS PRESSURE			200-430	538-4224
Natural	Minimum	kPa	1.13	1.13
	Test Point	kPa	0.77	0.92
	Maximum	kPa	3.50	4.00
Propane	Minimum	kPa	2.75	-
	Test Point	kPa	2.75	-
	Maximum	kPa	3.50	-

THERMOSTAT SETTINGS			
Modulating	Maximum	°C	95
	Factory set	°C	78
	Minimum	°C	44
On/Off	Maximum	°C	80
	Factory set	°C	50
	Minimum	°C	44

CLEARANCES COMBUSTIBLES (mm) ³					
Model	Back	Front	Left	Right	Ceiling
200 to 430	500	750	600	500	1,200
538 to 1922	600	750	600	600	1,200
2004 to 4224	600	1,200	600	600	1,200

CLEARANCES NON COMBUSTIBLES (mm) ³					
Model	Back	Front	Left	Right	Ceiling
200 to 430	150	750	600	150	1,200
538 to 1922	150	750	600	600	1,200
2004 to 4224	300	1,200	600	600	1,200

³ Excludes flue terminal clearances. Refer to AS/NZS 5601.1.

⁴ Expansion Control Valve is not supplied with the water heater.

⁵ An 850kPa relief valve can be fitted to modulating water heaters used in potable hot water applications.

