

Features & Benefits

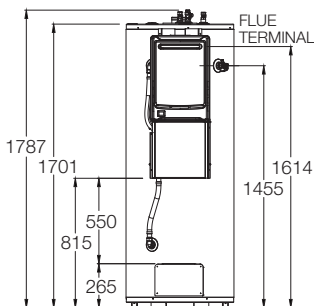

- Complete Frost Protection – Drain-Back heat exchange technology
- Complies with regulations in all states
- Booster – 26 L/min 6-star gas continuous flow (site integrated)
- Full mains pressure for multiple outlets
- Integrated tempering valve
- 2 or 3 SPA2000 or CSA2007 collectors
- Eligible for STCs⁵
- 5 year cylinder warranty¹

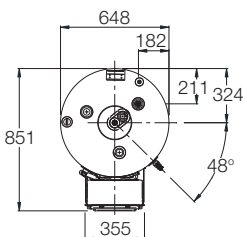

MODEL	596270
Storage Capacity (L)	270
Solar Collectors	2 or 3 SPA2000 2 or 3 CSA2007
Booster Type	Gas
Weight Empty - (kg) Tank without booster	168
Weight Empty - (kg) Tank with booster	187
Water Connections	Rp ³ / ₄
Gas Connections	R ³ / ₄



Tap QR code for
installation
instructions

