

# *Owner's Guide and Installation Instructions*



## *Gas Heavy Duty Water Heater 260 litre models*



*This water heater must be installed and serviced by a qualified person.  
Please leave this guide with a responsible officer.*

 **Warning:** Upon completion of the installation and commissioning of the water heater, leave this guide with the householder or responsible officer. **DO NOT** leave this guide inside of the cover of the water heater, as it may interfere with the safe operation of the water heater or ignite when the water heater is turned on.

---

An electronic copy of these Owner's Guide and Installation Instructions can be downloaded from [rheem.com.au](http://rheem.com.au) and [rheem.co.nz](http://rheem.co.nz).

**PATENTS**

This water heater may be protected by one or more patents or registered designs in the name of Rheem Australia Pty Ltd.

**TRADEMARKS**

® Registered trademark of Rheem Australia Pty Ltd.  
™ Trademark of Rheem Australia Pty Ltd.

**Note:** Every care has been taken to ensure accuracy in preparation of this publication. No liability can be accepted for any consequences, which may arise as a result of its publication.

---

# CONTENTS

---

## RESPONSIBLE OFFICER

This booklet contains important information about your new water heater, including terms of the Rheem warranty.

We recommend you read pages 7 to 19, and the terms of the Rheem warranty on pages 4 to 6.

The other pages are intended for the installer but may be of interest.

|   |           |
|---|-----------|
| <b>Warranty .....</b>                             | <b>4</b>  |
| <b>Safety, Warnings, Installation Notes .....</b> | <b>7</b>  |
| <b>About Your Water Heater.....</b>               | <b>10</b> |
| <b>Maintenance Requirements.....</b>              | <b>13</b> |
| <b>Water Supplies.....</b>                        | <b>15</b> |
| <b>Save A Service Call .....</b>                  | <b>18</b> |
| <b>Installation.....</b>                          | <b>20</b> |
| <b>Connections – Plumbing .....</b>               | <b>28</b> |
| <b>Multiple Installations .....</b>               | <b>31</b> |
| <b>Commissioning.....</b>                         | <b>35</b> |
| <b>Lighting The Water Heater.....</b>             | <b>36</b> |
| <b>Draining The Water Heater .....</b>            | <b>39</b> |

**RHEEM AUSTRALIA PTY LTD, A.B.N. 21 098 823 511**

[www.rheem.com.au](http://www.rheem.com.au), [www.rheem.co.nz](http://www.rheem.co.nz)

For Service Telephone 131 031 AUSTRALIA or 0800 657 335 NEW ZEALAND

---

# **RHEEM HEAVY DUTY GAS MAINS PRESSURE WATER HEATER WARRANTY - AUSTRALIA AND NEW ZEALAND ONLY**

---

## **GAS WATER HEATER MODELS 620260, 630260**

### **1. THE RHEEM WARRANTY – GENERAL**

- 1.1 This warranty is given in Australia by Rheem Australia Pty Limited ABN 21 098 823 511 of 1 Alan Street, Rydalmere New South Wales, and in New Zealand by Rheem New Zealand Limited of 475 Rosebank Road Avondale Auckland 1026.
- 1.2 Rheem offer a trained and qualified national service network who will repair or replace components at the address of the water heater subject to the terms of the Rheem warranty. Rheem Service, in addition can provide preventative maintenance and advice on the operation of your water heater. The Rheem Service contact number in Australia is 131031, with Contact Centre personnel available 24 hours, 7 days a week to take your call and if necessary to arrange a service call for during normal working hours Monday to Friday (hours subject to change) or in New Zealand on 0800 657 335.
- 1.3 For details about this warranty, you can contact us in Australia on 131031 or by email at [warrantyenquiry@rheem.com.au](mailto:warrantyenquiry@rheem.com.au) (not for service bookings), or in New Zealand on 0800 657 335 or by email at [rheem@rheem.co.nz](mailto:rheem@rheem.co.nz) (not for service bookings).
- 1.4 The terms of this warranty and what is covered by it are set out in sections 2 and 3 and apply to water heaters manufactured from the 1<sup>st</sup> August 2018.
- 1.5 If a subsequent version of this warranty is published, the terms of that warranty and what is covered by it will apply to water heaters manufactured after the date specified in the subsequent version.

### **2. TERMS OF THE RHEEM WARRANTY AND EXCLUSIONS TO IT**

- 2.1 The decision of whether to repair or replace a faulty component is at Rheem's sole discretion.
- 2.2 If you require a call out and we find that the fault is not covered by the Rheem warranty, you are responsible for our standard call out charge. If you wish to have the relevant component repaired or replaced by Rheem, that service will be at your cost.
- 2.3 Where a failed component or cylinder is replaced under this warranty, the balance of the original warranty period will remain effective. The replacement does not carry a new Rheem warranty.
- 2.4 Where the water heater is installed outside the boundaries of a metropolitan area as defined by Rheem or further than 25 km from either a regional Rheem branch office or an Accredited Rheem Service Agent's / Centre's office, the cost of transport, insurance and travelling between the nearest branch office or Rheem Accredited Service Agent's / Centre's office and the installed site shall be the owner's responsibility.
- 2.5 Where the water heater is installed in a position that does not allow safe or ready access, the cost of that access, including the cost of additional materials handling and/or safety equipment, shall be the owner's responsibility. In other words, the cost of dismantling or removing cupboards, doors or walls and the cost of any special equipment to bring the water heater to floor or ground level or to a serviceable position is not covered by this warranty.
- 2.6 This warranty only applies to the original and genuine Rheem water heater in its original installed location and any genuine Rheem replacement parts.
- 2.7 The Rheem warranty does not cover faults that are a result of:
  - a) Accidental damage to the water heater or any component (for example: (i) Acts of God such as floods, storms, fires, lightning strikes and the like; and (ii) third party acts or omissions).
  - b) Misuse or abnormal use of the water heater.
  - c) Installation not in accordance with the Owner's Guide and Installation Instructions or with relevant statutory and local requirements in the State or Territory in which the water heater is installed.

# RHEEM HEAVY DUTY GAS MAINS PRESSURE WATER HEATER WARRANTY - AUSTRALIA AND NEW ZEALAND ONLY

## GAS WATER HEATER MODELS 620260, 630260

- d) Connection at any time to a water supply that does not comply with the water supply guidelines as outlined in the Owner's Guide and Installation Instructions.
  - e) Repairs, attempts to repair or modifications to the water heater by a person other than Rheem Service or a Rheem Accredited Service Agent / Centre.
  - f) Faulty plumbing or faulty gas supply.
  - g) Failure to maintain the water heater in accordance with the Owner's Guide and Installation Instructions.
  - h) Transport damage.
  - i) Fair wear and tear from adverse conditions (for example, corrosion).
  - j) Cosmetic defects.
- 2.8 Subject to any statutory provisions to the contrary, this warranty excludes any and all claims for damage to furniture, carpet, walls, foundations or any other consequential loss either directly or indirectly due to leakage from the water heater, or due to leakage from fittings and/ or pipe work of metal, plastic or other materials caused by water temperature, workmanship or other modes of failure.
- 2.9 If the water heater is not sized to supply the hot water demand in accordance with the guidelines in the Rheem water heater literature, any resultant fault will not be covered by the Rheem warranty.
- 2.10 In New Zealand this warranty excludes to the extent permissible all implied warranties set out in the Sale of Goods Act 1908 (New Zealand) and all guarantees set out in the Consumers Guarantees Act 1993 (New Zealand) to the extent that the goods are acquired for the purpose of resupply in trade consumption in the course of a process of production or manufacture or repairing or treating in trade other goods or fixtures on land.

### 3. WHAT IS COVERED BY THE RHEEM WARRANTY FOR THE WATER HEATERS DETAILED IN THIS DOCUMENT

- 3.1 Rheem will repair or replace a faulty component of your water heater if it fails to operate in accordance with its specifications as follows:

| What components are covered   | The period from the date of installation in which the fault must appear in order to be covered | What coverage you receive   |
|---|--|---|
| <b>620, 630 series 260 models</b>   |  |   |
| <b>All components</b>   | Year 1   | Repair and/or replacement of the faulty component, free of charge, including labour.                            |
| <b>The cylinder</b><br>(if the water heater is installed in a single-family domestic dwelling)            | Years 2 to 5   | Repair and / or replacement of the cylinder, free of charge, including labour.                                  |
|   | Years 6 to 10  | Replacement cylinder, free of charge. Installation and repair labour costs are the responsibility of the owner. |
| <b>The cylinder</b><br>(if the water heater is <u>not</u> installed in a single-family domestic dwelling) | Years 2 to 5   | Replacement cylinder, free of charge. Installation and repair labour costs are the responsibility of the owner. |

---

# **RHEEM HEAVY DUTY GAS MAINS PRESSURE WATER HEATER WARRANTY - AUSTRALIA AND NEW ZEALAND ONLY**

---

## **GAS WATER HEATER MODELS 620260, 630260**

### **4. ENTITLEMENT TO MAKE A CLAIM UNDER THIS WARRANTY**

- 4.1 To be entitled to make a claim under this warranty you need to:
- a) Be the owner of the water heater or have consent of the owner to act on their behalf.
  - b) Contact Rheem Service without undue delay after detection of the defect and, in any event, within the applicable warranty period.
- 4.2 You are **not** entitled to make a claim under this warranty if your water heater:
- a) Does not have its original serial numbers or rating labels.
  - b) Is not installed in Australia or New Zealand.

### **5. HOW TO MAKE A CLAIM UNDER THIS WARRANTY**

- 5.1 If you wish to make a claim under this warranty, you need to:
- a) Contact Rheem on 131031 in Australia or 0800 657 335 in New Zealand and provide owner's details, address of the water heater, a contact number and date of installation of the water heater or if that's unavailable, the date of manufacture and serial number (from the rating label on the water heater).
  - b) Rheem will arrange for the water heater to be tested and assessed on-site.
  - c) If Rheem determines that you have a valid warranty claim, Rheem will repair or replace the water heater in accordance with this warranty.
- 5.2 Any expenses incurred in the making of a claim under this warranty will be borne by you.

### **6. THE AUSTRALIAN CONSUMER LAW**

- 6.1 In Australia, our goods come with guarantees that cannot be excluded under the Australian Consumer Law. You are entitled to a replacement or refund for a major failure and for compensation for any other reasonably foreseeable loss or damage. You are also entitled to have the goods repaired or replaced if the goods fail to be of acceptable quality and the failure does not amount to a major failure.
- 6.2 The Rheem warranty (set out above) is in addition to any rights and remedies that you may have under the Australian Consumer Law.

### **7. THE CONSUMER GUARANTEES ACT 1993 (NEW ZEALAND)**

- 7.1 In New Zealand, our goods come with guarantees that cannot be excluded under the Consumer Guarantees Act 1993 (New Zealand). If the goods fail to comply with the applicable guarantees set out under the Consumer Guarantees Act 1993 (New Zealand) being the guarantee as to acceptable quality, the guarantee as to correspondence with description or the guarantee as to repair and parts, or if the goods fail to comply with any express guarantee given by Rheem, then you are entitled to a replacement or refund and for compensation for any other reasonably foreseeable loss or damage.
- 7.2 The Rheem warranty (set out above) is in addition to any rights and remedies that you may have under the Consumer Guarantees Act 1993 (New Zealand).

---

## SAFETY, WARNINGS, INSTALLATION NOTES

---

It is important you read the following safety and warnings information.

### **⚠ SAFETY AND WARNINGS**

- This water heater is only intended to be operated by persons who have the experience or the knowledge and the capabilities to do so.
- This water heater is not intended to be operated by persons with reduced physical, sensory or mental capabilities i.e. the infirm, or by children. Children should be supervised to ensure they do not interfere with the water heater.
- This water heater is supplied with a thermostat, an over-temperature cut-out, and a combination temperature pressure relief valve. These devices must not be tampered with or removed. The water heater must not be operated unless each of these devices is fitted and is in working order.

The Rheem warranty may not cover faults if safety devices or the relief valve are tampered with or if the installation is not in accordance with these instructions.

- The water heater will operate until a water temperature of up to 65°C is reached, depending upon the setting of the thermostat.

Refer to [“How Hot Should The Water Be?”](#) on page 10.

- The lever on the temperature pressure relief valve and expansion control valve (if fitted) requires to be operated every six (6) months to clear any deposits and to ensure the valve and its drain line are not blocked.

Refer to [“Relief Valves”](#) on page 8 and [“Minor Maintenance Every Six Months”](#) on page 13.

- For continued safety of this water heater it must be installed, operated and maintained in accordance with the Owner's Guide and Installation Instructions.
- Servicing of the water heater must only be carried out by qualified personnel. Phone Rheem Service or their nearest Accredited Service Agent / Centre.
- Only a person qualified to install or service a water heater can drain the water heater, if this is required.
- Do not modify this water heater.
- Do not spray **aerosols** in the vicinity of this water heater while it is in operation. Propellants and gases in many aerosol sprays contain hydrocarbons which are flammable. Gases from aerosol sprays may also become corrosive when drawn into a flame.
- Do not use or store **flammable materials** in or near this water heater. Flammable liquids (such as petrol), combustible materials (such as newspapers) and similar articles must be kept well away from the water heater and the draught diverter or flue terminal.
- Do not store **swimming pool chemicals, household cleaners, etc.**, near the water heater.
- Do not place articles on or against this water heater, or in contact with the draught diverter or flue terminal. Ensure the draught diverter or flue terminal is not obstructed in any way at any time.
- Do not use Propane / Butane gas mixtures in a Propane model. A Propane model is designed to operate on Propane only. The use of Propane / Butane mixture, such as automotive LP gas fuel, in a Propane model is unsafe and can cause damage to the water heater.



## RELIEF VALVES

### Temperature Pressure Relief Valve

This water heater incorporates a temperature pressure relief valve located near the top of the water heater. This valve is essential for the water heater's safe operation.

It is possible for the valve to discharge a quantity of water through the drain line during each heating period. This quantity should be equal to approximately 1/50 of the hot water used, as water expands by this volume when heated.

### Expansion Control Valve

In many areas, including South Australia, Western Australia, New Zealand and scaling water areas, it is mandatory an expansion control valve is fitted to the cold water line to the water heater.

The expansion control valve will discharge the quantity of water from its drain line during the heating period instead of the temperature pressure relief valve as it has a lower pressure rating.

### Valve Operation

Continuous leakage of water from either valve and its drain line may indicate a problem with the water heater. Refer to [“Temperature Pressure Relief Valve or Expansion Control Valve Running”](#) on page 19.

**⚠ Warning:** Never block the outlet of either valve or their drain lines for any reason. A relief valve drain must be left open to atmosphere, and be installed in a continuously downward direction.

In locations where water pipes are prone to freezing, the relief valve drain line must be insulated and not exceed 300 mm in length before discharging into a tundish through an air gap.

Operate the easing lever on the temperature pressure relief valve and expansion control valve once every six (6) months to clear any deposits and ensure the valve and its drain line are not blocked. **It is very important the lever is raised and lowered gently.** Refer to [“Minor Maintenance Every Six Months”](#) on page 13.

**⚠ Warning:** Water discharged from the temperature pressure relief valve drain line will be hot. Exercise care to avoid any splashing of water by standing clear of the drain line's point of discharge when operating either valve's easing lever.

**⚠ Warning:** Failure to operate the easing lever on the relief valve once every six (6) months may result in the water heater cylinder failing.

If water does not flow freely from the drain line when the lever is lifted, then the water heater must be checked. Phone Rheem Service or their nearest Accredited Service Agent / Centre to arrange for an inspection.

The temperature pressure relief valve should be replaced at intervals not exceeding five (5) years and the expansion control valve should be checked for performance or replaced at intervals not exceeding five (5) years. The checking of the valves performance or replacement should occur more frequently in areas where there is a high incidence of water deposits. Refer to [“Water Supplies”](#) on page 15.

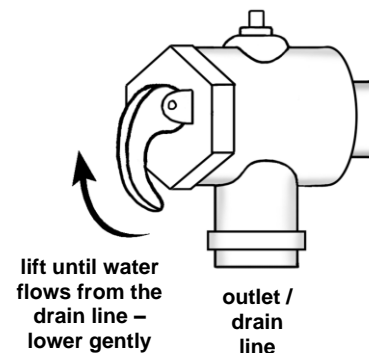
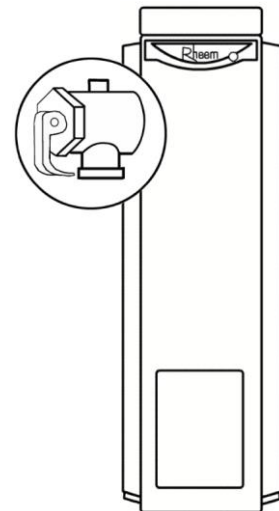



**INSTALLATION NOTES**

This water heater must be installed:

- by a qualified person,
- in accordance with the installation instructions,
- in compliance with the Plumbing Code of Australia (PCA) and Plumbing Standard AS/NZS 3500.4,
  - The 620 series water heaters are designed for indoor installation and the 630 series water heaters are designed for outdoor installation.
  - This water heater is intended to be permanently connected to the water mains and not connected by a hose-set. A braided flexible hose or semi-flexible connector may be used for connection to the water heater, where permitted by AS/NZS 3500.4.
- in compliance with the Gas Installations Standard AS/NZS 5601.1,
- in compliance with all local codes and regulatory authority requirements,
- in New Zealand also conforming to Clauses G11, G12 and H1 of the New Zealand Building Code.

Installation and commissioning requirements and details for the installing plumber are contained on [pages 20 to 36](#).

**Mains pressure water supply**

The water heater is designed to operate at mains pressure by connecting directly to the mains water supply.

The water heater is supplied with a temperature pressure relief valve with a pressure rating of 1000 kPa. If an expansion control valve has been installed on the cold water line to the water heater, this should have a pressure rating of 850 kPa.

The maximum mains water supply pressure for the water heater is 800 kPa if an expansion control valve is not installed, or 680 kPa if an expansion control valve is installed. If the mains supply pressure in your area exceeds these values, a pressure limiting valve must be installed.

The supply pressure should be greater than 350 kPa for true mains pressure operation to be achieved.

---

# ABOUT YOUR WATER HEATER

---

## WATER HEATER APPLICATION

This water heater is designed for the purpose of heating potable water. Its use in an application other than this may shorten its life.

## MODEL TYPE

The model Rheem® Heavy Duty Gas water heater you have chosen is a quick recovery water heater.

Water is stored in a vitreous enamel lined steel cylinder and heated by a gas burner located under the cylinder. The heat produced by the burner is transferred to the water through the base of the cylinder and through the wall of a flue pipe which passes through the centre of the cylinder. A flue baffle in this flue ensures the efficiency of the water heater is correct. The gas supply to the burner is controlled by the thermostat so the water is heated to a constant temperature.

Automatic safety controls are fitted to the water heater to provide safe and efficient operation.

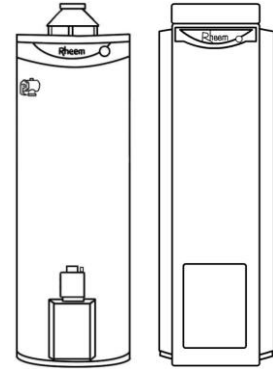

## HOW HOT SHOULD THE WATER BE?

The water heater features a user adjustable thermostat, which allows you to personally choose the most suitable temperature for your hot water needs. Refer to “[Temperature Adjustment](#)” on page 11.

To meet the requirements of the National Plumbing Standard the temperature of the stored water must not be below 60°C.

If this water heater is installed as an in-series booster water heater as part of a commercial solar water heating system, it is recommended the thermostat is set at 60°C to maximise solar contribution.

**Note:** Australian Standard AS 3498 and New Zealand Building Code Clause G12 requires that a water heater provides the means to inhibit the growth of Legionella bacteria in potable water. This water heater can satisfy these AS 3498 and Clause G12 requirements provided it is operating and the thermostat setting is 60°C or higher, including when it is used as an in-series booster water heater for a solar water heater.

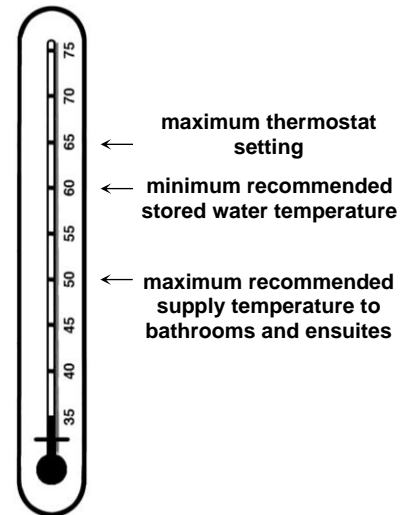

## HOTTER WATER INCREASES THE RISK OF SCALD INJURY

This water heater can deliver hot water at a temperature up to 65°C depending upon its thermostat setting. This temperature is sufficiently hot to cause severe scalding. Water at this temperature may have been plumbed to fixtures where water hotter than 50°C is allowed, such as a kitchen or laundry.

Check the water temperature before use, such as when entering a shower or filling a bath or basin, to ensure it is suitable for the application and will not cause scald injury.

We recommend and it may be required by regulations that an approved temperature limiting device be fitted into the hot water pipe work to bathrooms, ensuites, public amenities or other ablution areas when this water heater is installed. This will keep the water temperature below the maximum permitted by the Plumbing Code of Australia and New Zealand Building Code Clause G12 to these areas. The risk of scald injury will be reduced and still allow hotter water to the kitchen and laundry.

### TEMPERATURE ADJUSTMENT

The temperature adjusting dial is on the gas valve, located at the lower front of an indoor model and behind the access cover on the lower front on an outdoor model. A setting of '6' will normally maintain the water temperature at about 60°C. Each number represents a temperature difference of approximately 6°C.

To increase the water temperature to 65°C, turn the gas control knob anticlockwise to a setting of '7'. Refer to ["Hotter Water Increases the Risk of Scald Injury"](#) on page 10.

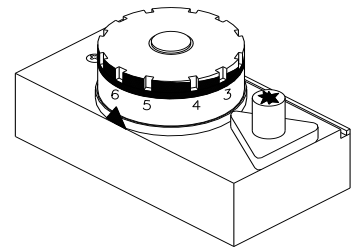

### PIEZO IGNITION

The "Piezo" push button igniter makes lighting the pilot flame of your water heater very easy. Simply follow the instructions on the label attached to the front of an indoor model and to the back of the access door on an outdoor model. There is no need for matches to light the water heater.

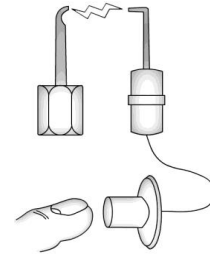

### PILOT IGNITER

A permanent pilot flame burns to ignite the main burner automatically. Heat from the pilot is absorbed by the water.

### PRECAUTIONS

Under certain installation conditions where damage to property can occur in the event of the water heater leaking, AS/NZS 3500.4 requires the water heater be installed in a safe tray. Construction, installation and draining of a safe tray must comply with AS/NZS 3500.4 and all local codes and regulatory authority requirements. In New Zealand the safe tray must also meet the requirements of Clause G12 of the New Zealand Building Code. Alternatively, where additional leak protection is required for installations not defined by AS/NZS 3500.4, a suitable bund may be constructed to surround the water heater in lieu of using a safe tray.

The water heater must be maintained in accordance with the Owner's Guide and Installation Instructions. Refer to ["Maintenance Requirements"](#) on page 13 and to ["Anode Inspection and Replacement"](#) on page 16.

If this water heater is to be used where an uninterrupted hot water supply is necessary for your application or business you should ensure that you have back-up redundancy within the hot water system design. This should ensure the continuity of hot water supply in the event that this water heater were to become inoperable for any reason. We recommend you seek advice from your plumber or specifier about your needs and building back-up redundancy into your hot water supply system.

### TO TURN OFF THE WATER HEATER

If it is necessary to turn off the water heater:

- Shut down the gas control (refer to ["Close Down Procedure"](#) on page 38).
- Close the gas isolation valve at the inlet to the gas control.
- Close the cold water isolation valve at the inlet to the water heater.

### TO TURN ON THE WATER HEATER

- Open the cold water isolation valve fully at the inlet to the water heater.
- Open the gas isolation valve fully at the inlet to the gas control.
- Light the water heater (refer to ["Lighting the Water Heater"](#) on page 36).

### **GOING ON HOLIDAYS**

If you are going on holiday for more than a few days the thermostat can be set to the “\*” (pilot) position to conserve energy (refer to point 1 of [“Close Down Procedure”](#) on page 38). If it is necessary to turn off the water heater, refer to [“To Turn Off The Water Heater”](#) on page 11.

### **VICTORIAN CUSTOMERS**

Notice to Victorian Customers from the Victorian Building Authority. This water heater must be installed by a licensed person as required by the Victorian Building Act 1993.

Only a licensed person will give you a Compliance Certificate, showing that the work complies with all the relevant Standards. Only a licensed person will have insurance protecting their workmanship for 6 years. Make sure you use a licensed person to install this water heater and ask for your Compliance Certificate.

### **DOES THE WATER CHEMISTRY AFFECT THE WATER HEATER?**

The water heater is suitable for most public water supplies, however some water chemistries may have detrimental effects on the water heater, its components and fittings. Refer to [“Water Supplies”](#) on page 15.

If you are in a known harsh water area or you are not sure of your water chemistry, have your water checked against the conditions [described on pages 15 to 17](#).

### **HOW LONG WILL THE WATER HEATER LAST?**

The water heater is supported by a manufacturer’s warranty ([refer to page 4](#)). There are a number of factors that will affect the length of service the water heater will provide. These include but are not limited to the water chemistry, the water pressure, the water temperature (inlet and outlet) and the water usage pattern. Refer to [“Precautions”](#) on page 11.

---

# MAINTENANCE REQUIREMENTS

---

## MINOR MAINTENANCE EVERY SIX MONTHS

It is recommended minor maintenance be performed every six (6) months. Minor maintenance can be performed by a responsible officer.

The minor maintenance includes:

- Operate the easing lever on the temperature pressure relief valve. **It is very important the lever is raised and lowered gently.** Refer to “Relief Valves” on page 8.  
  
**⚠ Warning:** Water discharged from the temperature pressure relief valve drain line will be hot. Exercise care to avoid any splashing of water by standing clear of the drain line's point of discharge when operating the valve's easing lever.
- Operate the easing lever on the expansion control valve (if fitted). **It is very important the lever is raised and lowered gently.** Refer to “Relief Valves” on page 8.
- Check the drain line from the safe tray (if one is installed) is not blocked.

## SERVICE EVERY TWELVE MONTHS

For safe and efficient operation, it is recommended a service be conducted on the water heater every twelve (12) months.

**⚠ Warning:** Servicing of a water heater must only be carried out by qualified personnel. Phone Rheem Service or their nearest Accredited Service Agent / Centre.

**Note:** The service and routine replacement of any components, if required, are not included in the Rheem warranty. A charge will be made for this work. Only genuine replacement parts should be used on this water heater.

The annual service includes the following actions:

- Inspect and flush the temperature pressure relief valve.
- Inspect and flush the expansion control valve (if fitted).
- Check and if necessary adjust the inlet gas pressure.
- Check the piezo igniter, gas control and thermocouple.
- Check the operation of and clean the pilot light and main burner.
- Visually check the unit for any potential problems.
- Inspect all connections.
- Check the drain line from the safe tray (if one is installed) is not blocked.

**Note:** The water heater may need to be drained during this service. After the completion of the service, the water heater will take some time to reheat the water. Hot water may not be available for a while.

### MAJOR SERVICE EVERY FIVE YEARS

It is recommended a major service be conducted on the water heater every five (5) years.

**⚠ Warning:** Servicing of a water heater must only be carried out by qualified personnel. Phone Rheem Service or their nearest Accredited Service Agent / Centre.

**Note:** The major service and routine replacement of any components, such as the anode and relief valve(s), are not included in the Rheem warranty. A charge will be made for this work. Only genuine replacement parts should be used on this water heater.

The major service includes the following actions:

- Replace the temperature pressure relief valve.
- Inspect and flush the expansion control valve (if fitted). If required, replace the valve.
- Inspect and if required, replace the anodes.

If the anodes are not replaced, they should be replaced within three (3) years of this service (refer to [“Anode Inspection and Replacement”](#) on page 16).

- Check and if necessary adjust the inlet gas pressure.
- Check the piezo igniter, gas control and thermocouple.
- Check the operation of and clean the pilot light and main burner.
- Drain and flush the water heater if required.

In commercial applications where large volumes of hot water are used, sediment may build up on the bottom of the cylinder and reduce the heating efficiency. In extreme cases, particularly in areas of high water sediment, draining and flushing out may be necessary.

- Visually check the unit for any potential problems.
- Inspect all connections.
- Check the drain line from the safe tray (if one is installed) is not blocked.

**Note:** The water heater may need to be drained during this service. After the completion of the service, the water heater will take some time to reheat the water. Hot water may not be available for a while.

# WATER SUPPLIES

**This water heater must be installed in accordance with this advice to be covered by the Rheem warranty.**

This water heater is manufactured to suit the water conditions of most public reticulated water supplies. However, there are some known water chemistries which can have detrimental effects on the water heater and its operation and / or life expectancy. If you are unsure of your water chemistry, you may be able to obtain information from your local water supply authority. This water heater should only be connected to a water supply which complies with these guidelines for the Rheem warranty to apply.

## CHANGE OF WATER SUPPLY

The changing or alternating from one water supply to another can have a detrimental effect on the operation and / or life expectation of a water heater cylinder and a temperature pressure relief valve.

Where there is a changeover from one water supply to another, e.g. a rainwater tank supply, bore water supply, desalinated water supply, public reticulated water supply or water brought in from another supply, then water chemistry information should be sought from the supplier or it should be tested to ensure the water supply meets the requirements given in these guidelines for the Rheem warranty to apply.

## ANODE

The vitreous enamel lined cylinder of the water heater is only covered by the Rheem warranty when the total dissolved solids (TDS) content in the water is less than 2500 mg/L and when the correct colour coded anode is used. If an incorrect colour coded anode is used in the water heater, any resultant faults will not be covered by the Rheem warranty. In addition, the use of an incorrect colour coded anode may shorten the life of the water heater cylinder.

The correct colour coded anode must be selected and fitted to the water heater in accordance with the following advice and the [Anode Selection chart](#) on page 15 for the Rheem warranty to apply to the water heater cylinder.

| Total Dissolved Solids | Anode colour code           |
|------------------------|-----------------------------|
| 0 – 40 mg/L            | Green                       |
| 40 – 150 mg/L          | Green or Black              |
| 150 – 400 mg/L         | Black                       |
| 400 – 600 mg/L         | Black or Blue               |
| 600 – 2500 mg/L        | Blue                        |
| 2500 mg/L +            | Blue (no cylinder warranty) |

The changing of anodes must be carried out by a qualified person.

**Note:** Some water analysis reports may state the conductivity of the water rather than the level of total dissolved solids. Conductivity, measured in microsiemens per centimetre ( $\mu\text{S} / \text{cm}$ ), is directly proportional to the TDS content of the water. TDS, in mg / L, is approximately 70% of the conductivity in  $\mu\text{S} / \text{cm}$ .

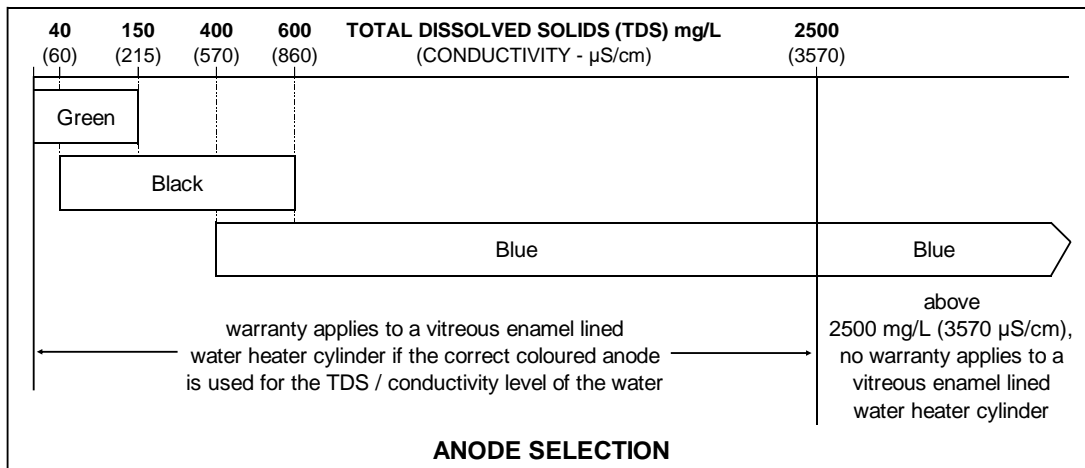

### **ANODE INSPECTION AND REPLACEMENT**

The anodes installed in your water heater will slowly dissipate whilst protecting the cylinder. The life of the cylinder may be extended by replacing the anodes.

For water supplies which are either softened or desalinated, or where the water supply may alternate between a water tank and a reticulated public supply or another supply, or where there is a variable supply (e.g. from a bore or public reticulated supply from various water sources), each anode must be inspected (and replaced if there is any sign of depletion) within five (5) years of its installation.

For all water supplies, if the anodes are not replaced during a major service (refer to [“Major Service Every Five Years”](#) on page 14) then the maximum time after installation when the anodes should be replaced for this gas water heater is eight (8) years.

### **CAUTION**

If the water supply has a TDS greater than 150 mg/L and a green anode has not been changed to a black anode, or if the TDS is greater than 600 mg/L and the anode has not been changed to a blue anode, there is the possibility the anode may become overactive and hydrogen gas could accumulate in the top of the water heater during long periods of no use.

If, under these conditions, the water heater has not been used for two or more weeks the following procedure should be carried out before using any electrical appliances (automatic washing machines and dishwashers) which are connected to the hot water supply.

The hydrogen, which is highly flammable, should be vented safely by opening a hot tap and allowing the water to flow. There should be no smoking or naked flame near the tap whilst it is turned on. Any hydrogen gas will be dissipated. This is indicated by an unusual spurting of the water from the tap. Once the water runs freely, any hydrogen in the system will have been released.

### **SATURATION INDEX**

The saturation index (SI) is used as a measure of the water's corrosive or scaling properties. The saturation index figures stated are calculated using a water temperature of 80°C.

In a corrosive water supply, the water can attack copper parts and cause them to fail.

In a scaling water supply calcium carbonate is deposited out of the water onto any hot metallic surface.

Where the saturation index exceeds +0.40, the water is very scaling. An expansion control valve must be fitted on the cold water line after the non-return valve to protect and for the Rheem warranty to apply to the temperature pressure relief valve and water heater cylinder.

Water which is scaling may be treated with a water softening device to reduce the saturation index of the water.

Refer to the [Saturation Index chart](#) on page 17.

Refer to the [cold water connection detail](#) on page 28 for the position of the expansion control valve.



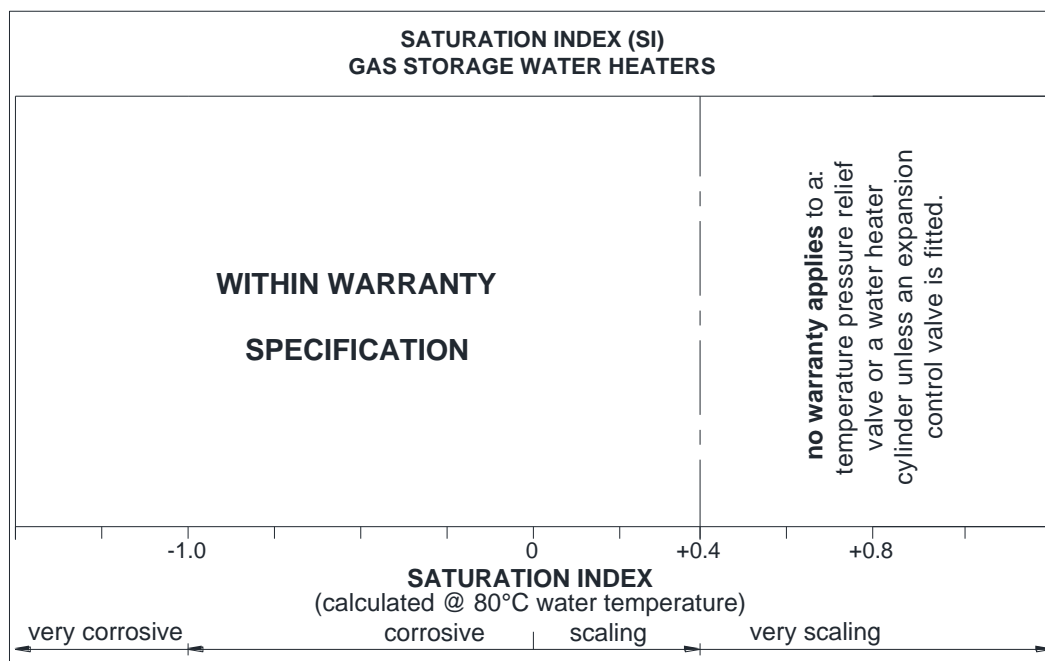

**SUMMARY OF WATER CHEMISTRY ADVICE AFFECTING WARRANTY**

The water heater and its components are not suitable for certain water chemistries. Those chemistries are listed below. If the water heater is connected at any time to a water supply with the following water chemistry, the Rheem warranty will not cover any resultant faults on the components listed below:

| <b>Water Chemistry</b>   | <b>Component</b>   |
|--|--|
| Total Dissolved Solids (TDS) > 2500 mg/L                                   | water heater cylinder                                      |
| Total Dissolved Solids (TDS) not suitable for anode type                   | water heater cylinder                                      |
| Saturation Index (SI) > +0.4<br>(if expansion control valve is not fitted) | water heater cylinder<br>temperature pressure relief valve |

---

## SAVE A SERVICE CALL

---

Check the items below before making a service call. You will be charged for attending to any condition or fault that is not related to manufacture or failure of a part.

### NOT ENOUGH HOT WATER (OR NO HOT WATER)

- **Are you using more hot water than you think?**  
Is one outlet (especially the shower) using more hot water than you think?

Very often it is not realised the amount of hot water used, particularly when showering. Carefully review the family's hot water usage.

Have your plumber fit a flow control valve to each shower outlet to reduce water usage.

- **Pilot flame alight?**  
Check the pilot flame is burning by viewing through the opening in the top of the front cover of an indoor model or by looking through the large opening below the gas control of an outdoor model. Relight the pilot flame according to the lighting instructions

Refer to "[Lighting the Water Heater](#)" on page 36.

- **Relief valve running**  
Is the relief valve discharging too much water?

Refer to "[Temperature Pressure Relief Valve or Expansion Control Valve Running](#)" on page 19.

- **Thermostat setting**  
Ensure the thermostat setting is appropriate. You may choose to adjust the thermostat upwards to gain additional hot water capacity.

**⚠ Warning:** Hotter water increases the risk of scald injury.

- **Water heater size**  
Do you have the correct size water heater for your requirements?

The sizing guide in the Rheem sales literature and on the Rheem website ([www.rheem.com.au](http://www.rheem.com.au)) suggests average sizes that may be needed.



### WATER NOT HOT ENOUGH

You may find that due to heavy hot water usage the water temperature may be lower than normally expected.

### CAN'T LIGHT THE PILOT FLAME

- **Is there gas to the water heater?**  
Check the gas isolation valve on the gas supply line is open.
- **Is there a normal gas supply to the rest of the premises?**  
Try lighting another gas appliance to check. If there is no gas, call the gas supplier.

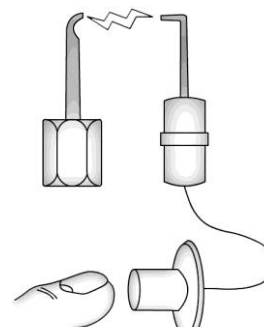

### WATER HEATER APPEARS TO BE LEAKING

When the water heater is first lit, or after a large usage of hot water, condensation may form on the burner of the water heater. This is quite normal, especially in winter months and will dry off as the water is heated.

## TEMPERATURE PRESSURE RELIEF VALVE OR EXPANSION CONTROL VALVE RUNNING

- **Normal Operation**

It is normal and desirable the temperature pressure relief valve or expansion control valve (if fitted) allows a quantity of water to escape during the heating cycle. This quantity should be equal to approximately 1/50 of the hot water used, as water expands by this volume when heated. However, if it discharges more than a bucket full of water in 24 hours, there may be another problem.

The expansion control valve (if fitted) will discharge water instead of the temperature pressure relief valve as it has a lower pressure rating. A benefit is that energy is conserved as the discharged water is cooler. This valve is installed in the cold water line to the water heater (refer to the [cold water connection diagram](#) on page 28).

- **Continuous dribble**

Try gently raising the easing lever on the relief valve for a few seconds (refer to [“Relief Valves”](#) on page 8). This may dislodge a small particle of foreign matter and clear the fault. Release the lever gently.

- **Steady flows for long period (often at night)**

This may indicate the mains water pressure sometimes rises above the designed pressure of the water heater. Ask your installing plumber to fit a pressure limiting valve.

**⚠ Warning:** Never replace the relief valve with one of a higher pressure rating.

- **Heavy flows of hot water from the temperature pressure relief valve until water heater is cold - then stops until the water reheats**

The gas control **must** be turned off using the knob on top of the gas control thermostat (refer to [“Close Down Procedure”](#) on page 38). Phone Rheem Service or their nearest Accredited Service Agent / Centre to arrange for inspection.

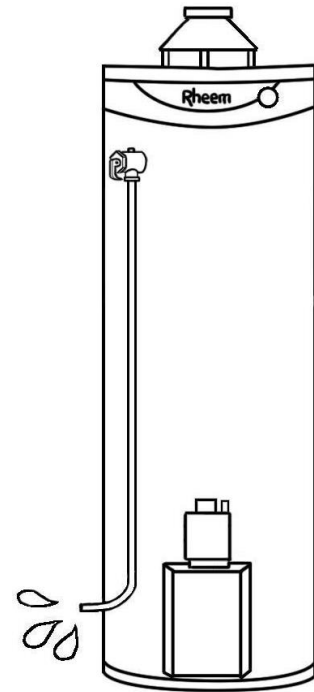

## HIGHER THAN EXPECTED GAS BILLS

Should you at any time, feel your gas bill is higher than expected, we suggest you check the following points:

- Is the relief valve running excessively?

Refer to [“Temperature Pressure Relief Valve or Expansion Control Valve Running”](#) on page 19.

- Is one outlet (especially the shower) using more hot water than you think?

Refer to [“Not Enough Hot Water”](#) on page 18.

- Is there a leaking hot water pipe, dripping hot water tap, etc?

Even a small leak will waste a surprising quantity of hot water and gas. Replace faulty tap washers, and have your plumber rectify any leaking pipe work.

- Has there been an increase in hot water usage?

An increase in hot water usage will result in an increase in water heater operation.

- Has your water heating tariff rate been increased by your gas retailer since your previous bill?

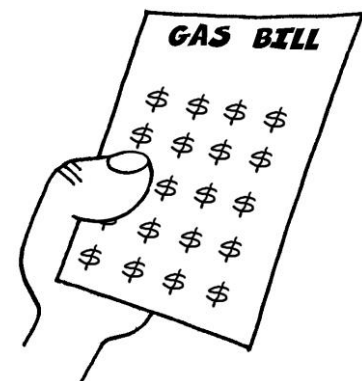

**IF YOU HAVE CHECKED ALL THE FOREGOING AND STILL BELIEVE YOU NEED ASSISTANCE, PHONE RHEEM SERVICE OR THEIR NEAREST ACCREDITED SERVICE AGENT / CENTRE.**

---

# INSTALLATION

---

**THIS WATER HEATER IS NOT SUITABLE FOR POOL HEATING.**  
**Check the water heater is suitable for the gas type available.**  
**(refer to the rating label on the water heater)**

## INSTALLATION STANDARDS

The water heater must be installed:

- by a qualified person, and
- in accordance the installation instructions, and
- in compliance with the Plumbing Code of Australia (PCA), Standards AS/NZS 3500.4 and AS/NZS 5601.1, and all local codes and regulatory authority requirements.
- in New Zealand also conforming to Clauses G11, G12 and H1 of the New Zealand Building Code.

**⚠ Warning:** This water heater may deliver water at high temperature. Refer to the Plumbing Code of Australia, local requirements and these installation instructions to determine if additional delivery temperature control is required. Refer to [“Hot Water Delivery”](#) on page 23.

All packaging materials must be removed from the water heater prior to its installation. This includes the removal of the cardboard base of the carton from the underside of the water heater and the protective packaging from the draught diverter of an indoor model.

## WATER HEATER APPLICATION

This water heater is designed for the purpose of heating potable water. Its use in an application other than this may shorten its life.

If this water heater is to be used where an uninterrupted hot water supply is necessary for the application or business, then there should be back-up redundancy within the hot water system design. This should ensure the continuity of hot water supply in the event that this water heater was to become inoperable for any reason. We recommend you provide advice to the system owner about their needs and building back-up redundancy into the hot water supply system.

**Note:** Australian Standard AS 3498 and New Zealand Building Code Clause G12 requires that a water heater provides the means to inhibit the growth of Legionella bacteria in potable water. This water heater can satisfy these AS 3498 and Clause G12 requirements provided it is operating and the thermostat setting is 60°C or higher, including when it is used as an in-series booster water heater for a solar water heater.

## WATER HEATER LOCATION

An indoor model must be installed indoors and an outdoor model must be installed outdoors.

The water heater should be installed close to the most frequently used outlets or with a circulated flow and return system and its position chosen with safety and service in mind. Make sure people (particularly children) will not touch the flue outlet. The flue terminal must be clear of obstructions and shrubbery.

Clearance must be allowed for servicing of the water heater. The water heater must be accessible without the use of a ladder or scaffold. Make sure the temperature pressure relief valve lever is accessible and the front cover and burner can be removed for service.

You must be able to read the information on the rating plate. If possible leave headroom of one water heater height so the anode can be inspected or replaced. Remember you may have to remove the entire water heater later for servicing.

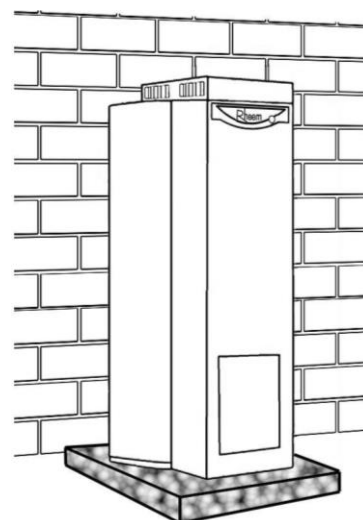

The water heater must not be installed in an area with a corrosive atmosphere where chemicals are stored or where aerosol propellants are released. Remember the air may be safe to breathe, but when it goes through a flame, chemical changes take place which may attack the water heater.

For a single water heater installation, follow the [diagrams on pages 27 and 26](#). For multiple water heater installations, follow the [instructions on pages 31 to 34](#).

### INDOOR INSTALLATION

The water heater is to be installed at floor level and must stand vertically upright on a stable fireproof base as acceptable to local authorities. There are special requirements in AS/NZS 5601.1 for water heaters installed in a garage, an enclosed space and other locations. Remember all local authorities have regulations about putting water heaters into roof spaces.

For indoor models the distances set out in the diagram should be observed. Keep the water heater and flue at least 25 mm clear of walls, cupboards, timber or any other combustibles and at least 500 mm clear of curtains and furnishings.

### Ventilation

A room or enclosure where the water heater is installed, including a plant room or residential garage, must comply with the ventilation and air supply requirements of AS/NZS 5601.1. Consideration must be given to other gas burning appliances installed in the same space.

### Secondary Flue

A secondary flue must be installed with an indoor gas water heater to discharge combustion products outside the building. The flue design and installation must comply with AS/NZS 5601.1.

**⚠ Warning:** Do not use an unlined masonry chimney as the flue for this water heater.

The water heater is supplied with a draught diverter and an adaptor, designed to receive a 100 mm diameter flue (620 260 model).

- Remove the draught diverter and adaptor from the protective packaging.
- Fit the draught diverter by inserting the tabs on the legs into the slots in the top of the water heater.
- Insert the adaptor into the outlet spigot of the draught diverter cone.

The secondary flue must:

- be seated inside of the adaptor of the draught diverter.
- be self-supporting and not impose a load on the water heater.
- use a slip joint or similar to allow for disconnection.
- be designed to run vertically for the maximum possible distance, and not less than 600 mm, before any change of direction.

### Safe Tray

Under certain installation conditions where damage to property can occur in the event of the water heater leaking AS/NZS 3500.4 requires the water heater be installed in a safe tray. Construction, installation and draining of a safe tray must comply with AS/NZS 3500.4 and all local codes and regulatory authority requirements. In New Zealand the safe tray must also meet the requirements of Clause G12 of the New Zealand Building Code. AS/NZS 3500.4 and the NZBC also have particular requirements when a safe tray must be installed. Alternatively, where additional leak protection is required for installations not defined by AS/NZS 3500.4, a suitable bund may be constructed to surround the water heater in lieu of using a safe tray.

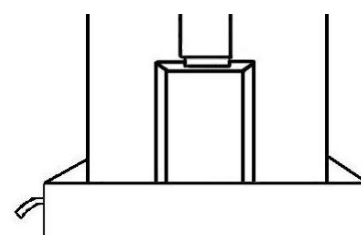
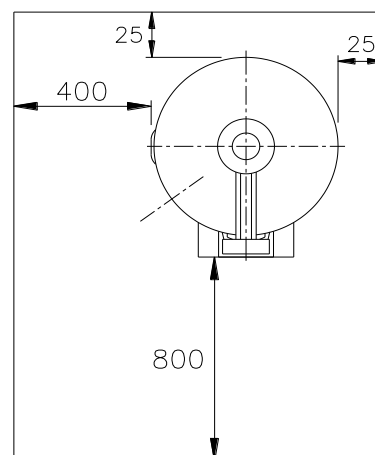
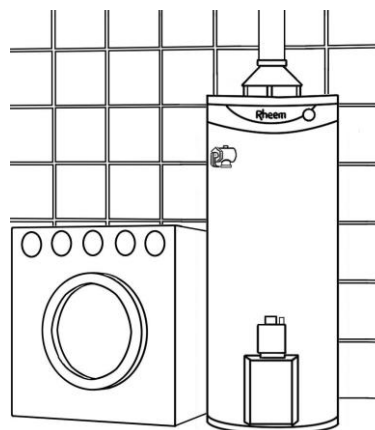

**OUTDOOR INSTALLATION**

The water heater is to be installed at ground or floor level on a stable fireproof base as acceptable to local authorities. The water heater must also stand vertically upright with the back of the water heater **against or within 25 mm of an external wall** or alternatively against a fireproof screen extending at least 500 mm above, below and either side the flue terminal. Failure to observe this precaution can cause problems in high wind areas. A secondary flue is not required.

The water heater must be located to ensure that the location of the flue terminal complies with the requirements of AS/NZS 5601.1. As a guide the following requirements are extracted from the Gas Installations Standard. The distances are measured along the wall behind the water heater.

- At least 500 mm between the top of the flue terminal and the eaves.
- At least 500 mm between the flue terminal and the edge of any opening into the building, such as an openable door or window, measured horizontally\* and vertically.
- At least 500 mm between the flue terminal and a return wall or external corner, measured horizontally\*.

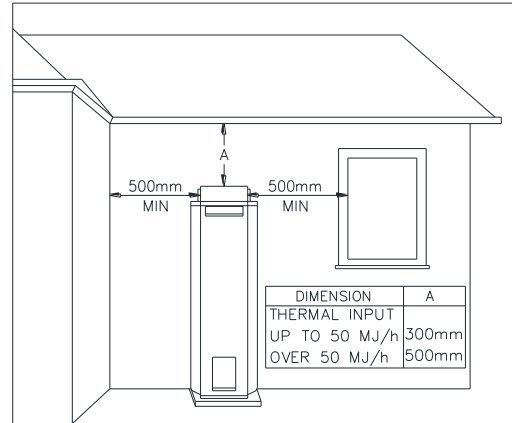

**Note:** \* If these horizontal distances cannot be achieved, AS/NZS 5601.1 states an equivalent horizontal distance measured diagonally from the nearest discharge point of the flue terminal to the opening may be deemed to comply. Check with the local regulator.

**MAINS WATER SUPPLY**

Where the mains water supply pressure exceeds that shown in the table below, an approved pressure limiting valve is required and should be fitted as shown in the [cold water connection diagram](#) on page 28.

| Model                                     | 260      |
|---|----------|
| Temperature pressure relief valve setting | 1000 kPa |
| Expansion control valve setting *         | 850 kPa  |
| Maximum mains supply pressure             |          |
| With expansion control valve              | 680 kPa  |
| Without expansion control valve           | 800 kPa  |

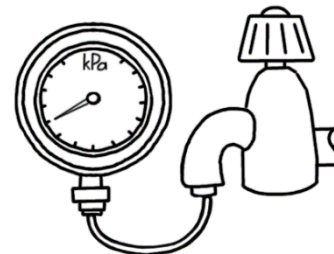

\* Expansion control valve not supplied with the water heater.

**TANK WATER SUPPLY**

If the water heater is supplied with water from a tank supply and a pressure pump system is not installed, then the bottom of the supply tank must be at least 1 m above the highest point of the hot water plumbing system, including the water heater. Care must be taken to avoid air locks. The cold water line to the water heater should be adequately sized and fitted with a full flow gate valve or ball valve.

**REDUCING HEAT LOSSES**

The cold water line to and the hot water line from the water heater must be insulated in accordance with the requirements of AS/NZS 3500.4. The insulation must be weatherproof and UV resistant if exposed.

**SADDLING - PIPE WORK**

To prevent damage to the cylinder when attaching pipe clips or saddles to the water heater jacket, we recommend the use of self-drilling screws with a maximum length of 13 mm. Should pre drilling be required, extreme caution must be observed when penetrating the jacket of the water heater.

**Note:** If the cylinder is damaged as a result of attaching pipe clips or saddles to the jacket, any resultant faults will not be covered by the Rheem warranty.

**ANODE**

The vitreous enamel lined cylinder of the water heater is only covered by the Rheem warranty when the total dissolved solids (TDS) content in the water is less than 2500 mg/L and when the correct colour coded anode is used. If an incorrect colour coded anode is used in the water heater, any resultant faults will not be covered by the Rheem warranty. In addition, the use of an incorrect colour coded anode may shorten the life of the water heater cylinder.

The correct colour coded anode for the water supply being used must be selected and fitted to the water heater for the Rheem warranty to apply to the water heater cylinder (refer to “Water Supplies” on page 15 and the Anode Selection table on page 15). The black anode is typically fitted as standard.

If an incorrect anode is used, there is also the possibility the anode may become overactive and hydrogen gas could accumulate in the top of the water heater during long periods of no use. In areas where this is likely to occur, the installer should instruct the householder on how to dissipate the gas safely (refer to “Caution” on page 16).

**HOT WATER DELIVERY**

This water heater can deliver hot water at a temperature up to 65°C depending upon its thermostat setting. This temperature is sufficiently hot to cause severe scalding. Water at this temperature may be plumbed to fixtures where water hotter than 50°C is allowed, such as a kitchen or laundry.

The installing plumber may have a legal obligation to ensure the installation of this water heater meets the water temperature delivery requirements of the Plumbing Code of Australia and New Zealand Building Code Clause G12 so that heated water delivered to fixtures and appliances used primarily for personal hygiene is at a temperature which is unlikely to scald.

It is necessary and we recommend that a temperature limiting device be fitted between the water heater and the fixtures and appliances used primarily for personal hygiene such as in a bathroom, ensuite, public amenities or other ablution areas, to reduce the risk of scalding.

Where a temperature limiting device is installed adjacent to the water heater, the cold water line to the temperature limiting device can be branched off the cold water line either before or after the isolation valve, pressure limiting valve and non-return valve to the water heater. If an expansion control valve is required, it must always be installed after the non-return valve and be the last valve prior to the water heater.

If a pressure limiting valve is installed on the cold water line to the water heater and the cold water line to a temperature limiting device branches off before this valve or from another cold water line in the premises, then a pressure limiting valve of an equal pressure setting may be required prior to the temperature limiting device.

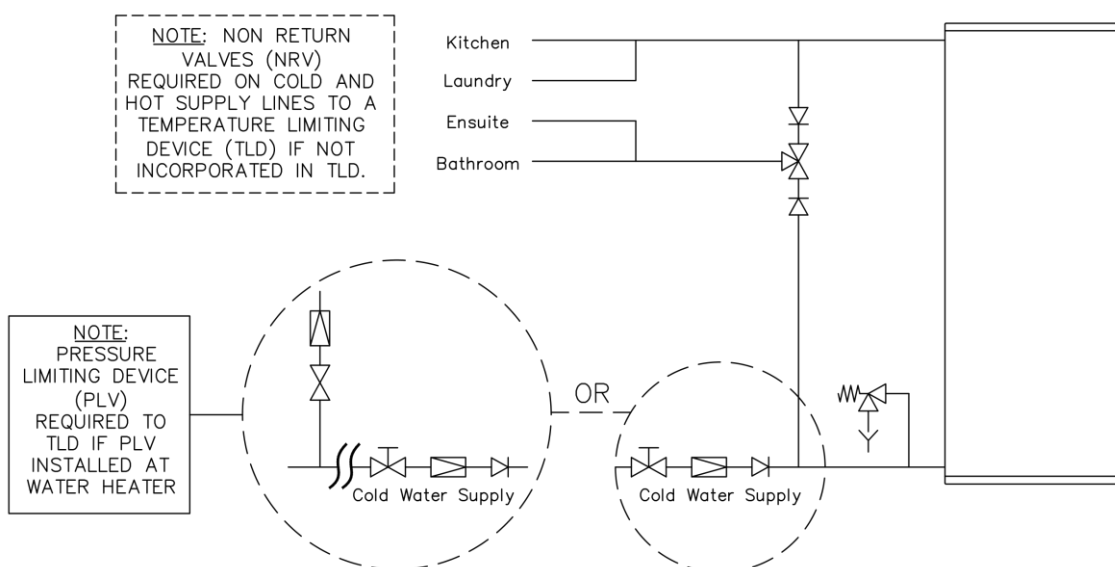

**Two Temperature Zones Using a Temperature Limiting Device**

**CIRCULATED HOT WATER FLOW AND RETURN SYSTEM**

A Rheem 620 or 630 series water heater can be installed as part of a circulated hot water flow and return system in a building.

**Temperature Settings**

- the thermostat setting of the water heater must be set to at least 60°C – AU or 65°C – NZ.  
In New Zealand an approved UV sterilisation or chlorine disinfection system may be used instead of setting the thermostat to 65°C.
- the return water temperature to the water heater must not be less than 55°C – AU or 60°C – NZ.  
If the water temperature decreases by more than 5°C due to heat loss from the ring main:
  - AU – the thermostat setting of the water heater must be set to above 60°C – AU to ensure the return water temperature is not less than 55°C.
  - NZ – an approved UV sterilisation or chlorine disinfection system may need to be used.

Refer to the [Circulated Hot Water Flow and Return System – Gas Water Heater](#) diagram on page 24.

**Temperature Limiting Device**

A temperature limiting device cannot be installed in circulated hot water flow and return pipe work unless it is specifically designed to do so, such as the Rheem Guardian warm water system.

The tempered water from a temperature limiting device cannot be circulated. Where a circulated hot water flow and return system is required in a building, a temperature limiting device can only be installed on a dead leg, branching off the circulated hot water flow and return pipe.

If circulated tempered water were to be returned back to the water heater, depending on the location of the return line connection on the water supply line to the water heater, then either:

- water will be supplied to the cold water inlet of the temperature limiting device at a temperature exceeding the maximum recommended water supply temperature, or
- when the hot taps are closed no water will be supplied to the cold water inlet of the temperature limiting device whilst hot water will continue to be supplied to the hot water inlet of the temperature limiting device.

These conditions may result in either water at a temperature exceeding the requirements of AS/NZS 3500.4 being delivered to the hot water outlets in the ablution areas, or the device closing completely and not delivering water at all, or the device failing. Under either condition, the operation and performance of the device cannot be guaranteed.

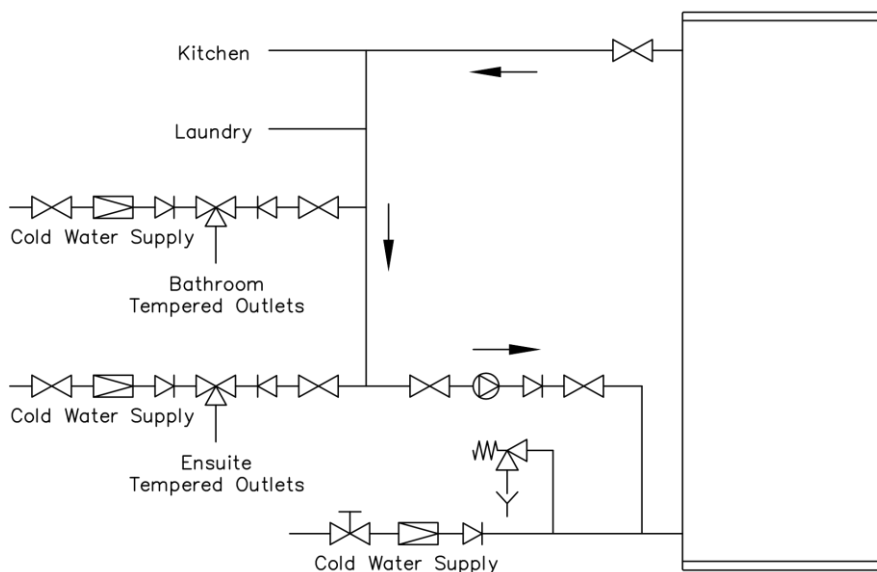

**Circulated Hot Water Flow and Return System – Gas Water Heater**



**DIMENSIONS AND TECHNICAL DATA**

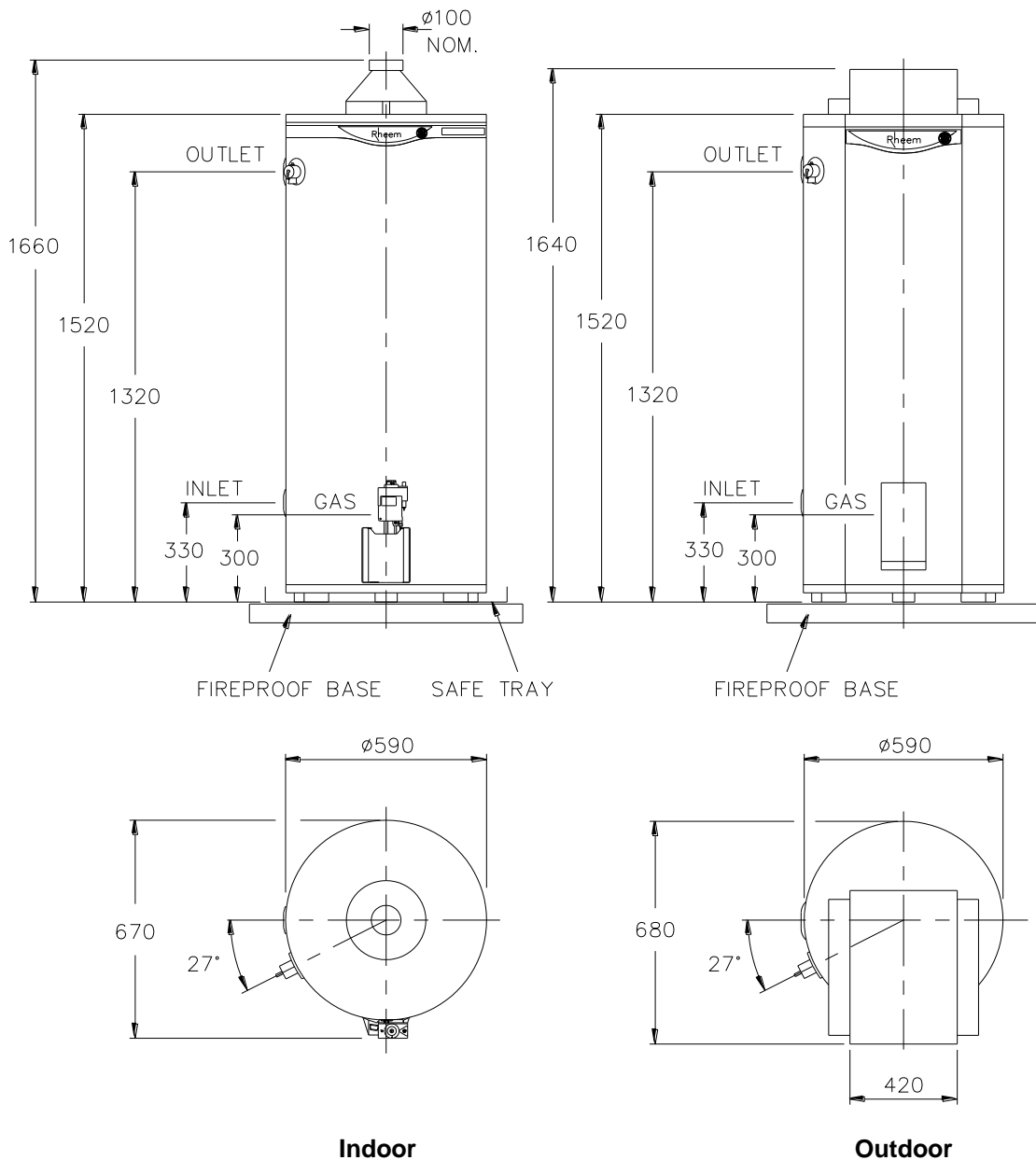

| Model                   |             | 620260 | 630260 |
|-------------------------|-------------|--------|--------|
| <b>Storage capacity</b> | litres      | 260    | 260    |
| <b>Mass (tank)</b>      | cartoned kg | 106    | 116    |
|                         | full kg     | 362    | 366    |

| Gas Details | Hourly Gas Consumption (MJ) | Min. Gas Pressure (kPa) | Test Point Gas Pressure (kPa) | Max. Gas Pressure (kPa) | Main Injector Orifice (mm) | Pilot Injector Number |
|-------------|-----------------------------|-------------------------|-------------------------------|-------------------------|----------------------------|-----------------------|
| Natural     | 51                          | 1.13                    | 1.00                          | 3.50                    | Ø 3.20                     | 27                    |
| Propane     | 51                          | 2.75                    | 2.70                          | 3.50                    | Ø 1.95                     | 16                    |

Model numbers: N = Natural, P = Propane. Letter N or P is included in the model number, e.g. 620260N0, to denote gas type.

Note: Propane model not available for New Zealand.

Technical data is subject to change.

TYPICAL INSTALLATION – OUTDOOR LOCATION

HOT WATER OUTLET

Use a union connection and insulate hot water pipe.

TEMPERATURE PRESSURE RELIEF VALVE

TEMPERATURE PRESSURE RELIEF VALVE DRAIN LINE

Drain line must terminate away from the base of the water heater. Discharge point must comply with AS/NZS 3500.4 .

COLD WATER CONNECTION

Cold water connection must comply with local regulations.

FLUE TERMINAL

Minimum distances to windows, doors and walls must be in accordance with regulatory authority requirement.

ACCESS COVER

Lighting instructions and rating plate are on the back of this cover. Cover must be replaced after lighting and remain in place when the water heater is operating. Piezo igniter and drain cock behind cover.

BASE

Level, stable, impervious base designed to avoid ponding.

GAS SUPPLY PIPE

Isolating valve and union must be used.

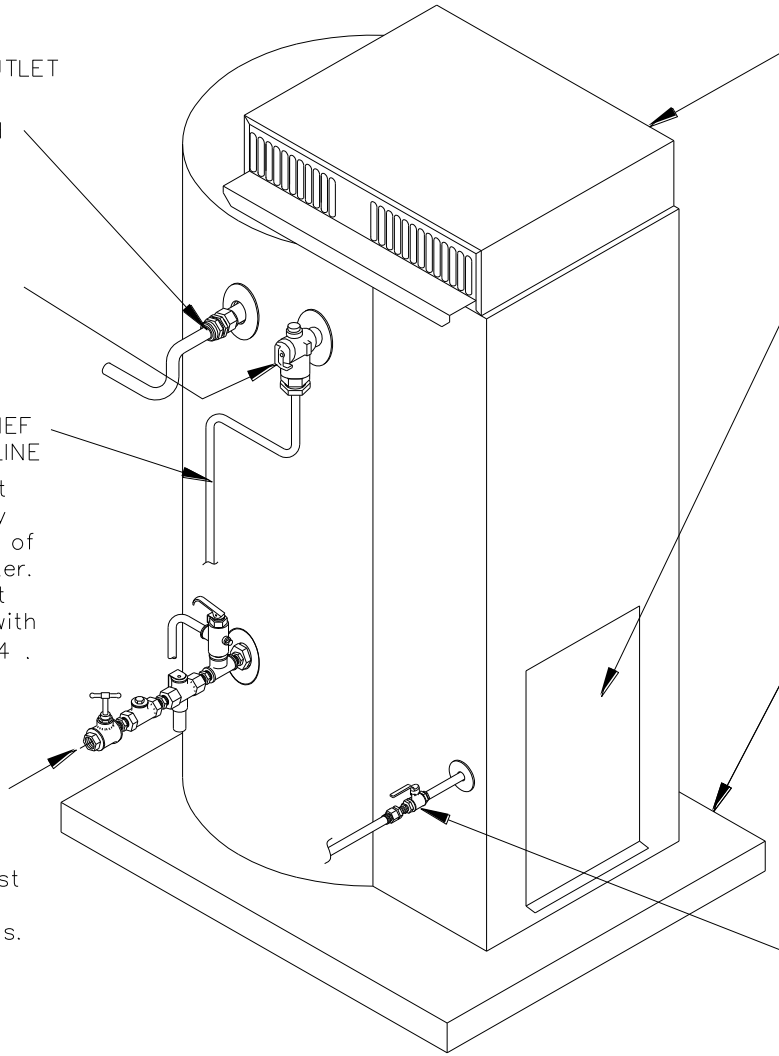

**TYPICAL INSTALLATION – INDOOR LOCATION**

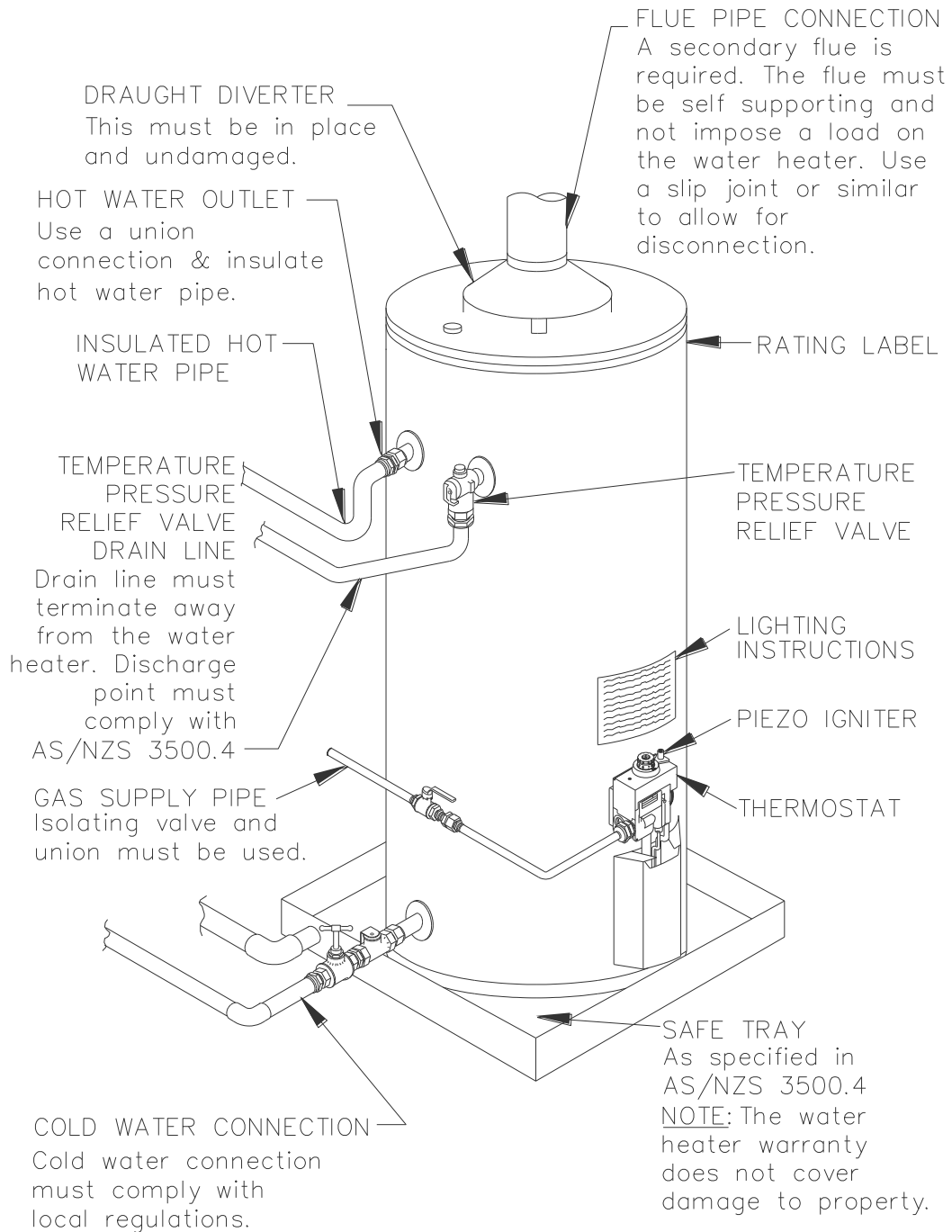

---

## CONNECTIONS – PLUMBING

---

All plumbing work must be carried out by a qualified person and in compliance with the Standard AS/NZS 3500.4 and all local codes and regulatory authority requirements.

All gas work must be carried out by a qualified person and in compliance with the Standard AS/NZS 5601.1, all local codes and regulatory authority requirements.

In New Zealand the installation must conform to Clauses G11, G12 and H1 of the New Zealand Building Code.

### CONNECTION SIZES

- Hot water connection: Rp 1 1/4
- Cold water connection: Rp 1 1/4
- Relief valve connection: Rp 3/4
- Gas inlet: Rp 1/2

### WATER INLET AND OUTLET

All pipe work must be cleared of foreign matter before connection and purged before attempting to operate the water heater. All olive compression fittings must use brass or copper olives. Use an approved thread sealant such as Teflon tape on all threaded joints.

An isolation valve and non-return valve must be installed on the cold water line to the water heater. An acceptable arrangement is shown in the diagram or [on page 33 for multiple installations](#). Refer also to “[Hot Water Delivery](#)” on page 23 and to “[Mains Water Supply](#)” on page 22.

A disconnection union must always be provided at the cold water inlet and hot water outlet on the water heater to allow for disconnection of the water heater.

This water heater has either a plastic dip tube or fitting liner in the inlet and outlet fittings (see diagram). These must be in place for the water heater to function properly. Do not remove or damage them by using heat nearby. They will be pushed into the correct position as the fitting is screwed in.

This water heater is intended to be permanently connected to the water mains and not connected by a hose-set. A braided flexible hose or semi-flexible connector may be used for connection to the water heater, where permitted by AS/NZS 3500.4.

### PIPE SIZES

The cold water pipe to the water heater should be the same size or bigger than the hot water line from the water heater.

The pipe sizing for hot water supply systems should be carried out by persons competent to do so, choosing the most suitable pipe size for each individual application. Reference to the technical specifications of the water heater and local regulatory authority requirements must be made.

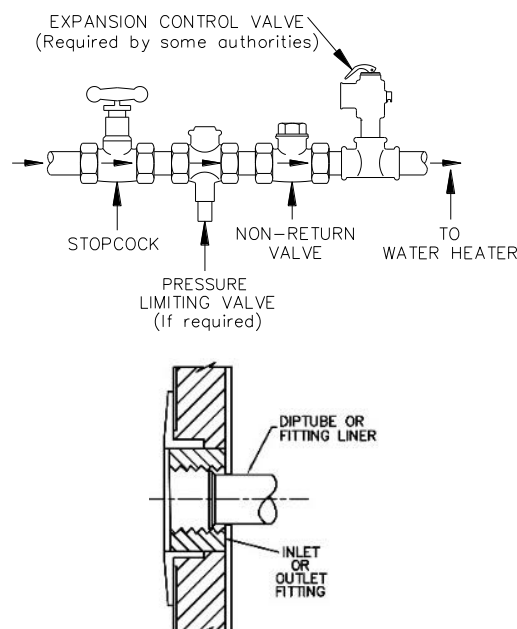

### TEMPERATURE PRESSURE RELIEF VALVE

The temperature pressure relief valve is shipped in the carton with the draught diverter of an indoor model and behind the front cover of an outdoor model. The temperature pressure relief valve must be fitted before the water heater is operated. Before fitting the relief valve, make sure the probe has not been bent.

To fit the relief valve:

- Seal the thread with an approved thread sealant such as Teflon tape - never hemp. Make sure tape does not hang over the end of the thread.
- Hand tighten the valve into the opening marked "Relief Valve" (refer to the [installation diagram on pages 27 and 26](#)).
- Using a spanner engaged on the valve's spanner flats and applying medium pressure to tighten, turn the relief valve an additional ½ to 1 ½ turns to secure and make the joint water tight, leaving the valve drain pointing downwards.

**⚠ Warning:** Do not use a pipe wrench or poor fitting tool on the valve body nor over tighten the valve, as this could damage the valve and prevent safe operation.

- Operate the easing lever on the valve to check the smooth operation of the valve plunger. It is very important the lever is raised and lowered gently. The lever should move smoothly and without undue force.
- If the lever cannot be moved or is jerky in its movement, then the valve has been damaged and must be replaced.
- A copper drain line must be fitted to the temperature pressure relief valve (refer to "[Relief Valve Drain](#)" on page 30).
- The valve must be insulated with closed cell polymer insulation or similar (minimum thickness 9 mm) and the insulation installed so as not to impede the operation of the valve.

The insulation must be weatherproof and UV resistant if exposed.

### EXPANSION CONTROL VALVE

Local regulations may make it mandatory to install an expansion control valve (ECV) in the cold water line to the water heater. In other areas, an ECV is required if the saturation index is greater than +0.4 (refer to "[Water Supplies](#)" on page 15).

The expansion control valve must always be installed after the non-return valve and be the last valve installed prior to the water heater (refer to [diagram on page 28](#)). A copper drain line must be fitted to the expansion control valve (refer to "[Relief Valve Drain](#)" on page 30).

The valve, if installed within 500 mm of the water heater, must be insulated with closed cell polymer insulation or similar (minimum thickness 9 mm) and the insulation installed so as not to impede the operation of the valve. The insulation must be weatherproof and UV resistant if exposed.

**RELIEF VALVE DRAIN**

DN20 copper drain lines must be fitted to the temperature pressure relief valve and expansion control valve (if one is installed) to carry the discharge clear of the water heater. Connect the drain lines to the valves using disconnection unions. The drain line from the valve to the point of discharge should be as short as possible, have a continuous fall all the way from the water heater to the discharge outlet and have no tap, valves or other restrictions in the pipe work.

A drain line from a relief valve must comply with the requirements of AS/NZS 3500.4.

A drain line must be no longer than 9 metres with no more than three bends greater than 45° before discharging at an outlet or air break. The maximum length of 9 metres for a drain line is reduced by 1 metre for each additional bend required of greater than 45°, up to a maximum of three additional bends. Where the distance to the point of final discharge exceeds this length, the drain line can discharge into a tundish.

Subject to local regulatory authority approval, the drain lines from the temperature pressure relief valve and expansion control valve from an individual water heater may be interconnected.

The outlet of a drain line must be in such a position that flow out of the pipe can be easily seen, but arranged so discharge will not cause injury, damage or nuisance. The termination point of a drain line must comply with the requirements of AS/NZS 3500.4. Drain lines must not discharge into a safe tray.

In locations where water pipes are prone to freezing, drain lines must be insulated, must not exceed 300 mm in length and are to discharge into a tundish through an air gap of between 75 mm and 150 mm.

If a drain line discharges into a tundish, the drain line from the tundish must be not less than DN25. The drain line from a tundish must meet the same requirements as for a drain line from a relief valve.

For multiple installations the drain line from each water heater can discharge into a common tundish (refer to [“Multiple Installations”](#) on pages 31 and 32).

**⚠ Warning:** As the function of the temperature pressure relief valve on this water heater is to discharge high temperature water under certain conditions, it is strongly recommended the pipe work downstream of the relief valve be capable of carrying water exceeding 93°C. Failure to observe this precaution may result in damage to pipe work and property.

**GAS INLET**

The gas connection is made to the left hand side of the gas control, through the grommet in the left hand side panel on outdoor models. The pipe work must be cleared of foreign matter before connection and purged before attempting to light the water heater. An isolation valve and disconnection union must be installed to allow servicing and removal of the water heater.

**Note:** Refer to the Gas Installations Standard AS/NZS 5601.1 for the correct method of sizing the gas supply pipe to the water heater. The pipe size selection must take into account the gas input of this water heater ([refer to table](#) on page 25) as well as all of the other gas appliances in the premises.

**⚠ Warning:** Always isolate the water heater before pressure testing the gas supply system. Disconnect the water heater after the isolating cock to prevent the risk of serious damage to the gas control. The Rheem warranty does not cover damage of any nature resulting from failure to observe this precaution. Refer to rating label for gas types and pressures.

**Caution:** Care is necessary when tightening fittings into the gas valve. The gas valve casting may crack if the fittings are over tightened. Cracked valve castings are not covered under the Rheem warranty. Damaged valves must be replaced.

---

## MULTIPLE INSTALLATIONS

---

A multiple installation of Rheem water heaters on a single manifold or multiple manifolds is possible, using the Rheem Equa-Flow® manifold system, where large volumes of hot water are required. The Equa-Flow principle will function with water heaters in line, around a corner or in rows back to back ([refer to the diagrams on page 32](#)).

The cold water and hot water manifolds must be designed to balance the flow from each water heater. To achieve this, there are basic installation requirements and principles which must be followed:

1. The maximum number of water heaters in a bank should be 8, however several banks of water heaters can be installed.
2. The hot water line from the manifold must leave from the opposite end to which the cold water line enters the manifold.
3. The water heaters must be of the same model.
4. The cold water line, cold and hot headers and hot water line must be sized to meet the requirements of both AS/NZS 3500.4 and the application.
5. A non-return valve, isolation valve and if required a pressure limiting valve and expansion control valve, must be installed on the cold water line to the system.
6. A full flow gate valve or ball valve (not a stop tap, as used on a single water heater installation) must be installed on both the cold water branch and hot water branch of each water heater.
7. Non-return valves or pressure limiting valves **must not** be installed on the branch lines to the water heaters.
8. All fittings, valves and branch lines must be matched sets all the way along the manifold.
9. Sufficient space must be left to enable access, servicing or removal of any water heater. Outdoor 630 260 models must be spaced at minimum 920 mm centres to provide the required clearance between flue terminals.
10. The temperature pressure relief valve drain line from each water heater can terminate at a common tundish (funnel) with a visible air break at each drain discharge point ([refer to the diagram on page 32](#) and to [“Relief Drain Line”](#) on page 30).

Refer to the [diagrams on pages 32 to 34](#) for installation and plant layout details.

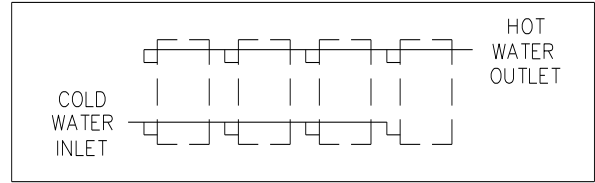
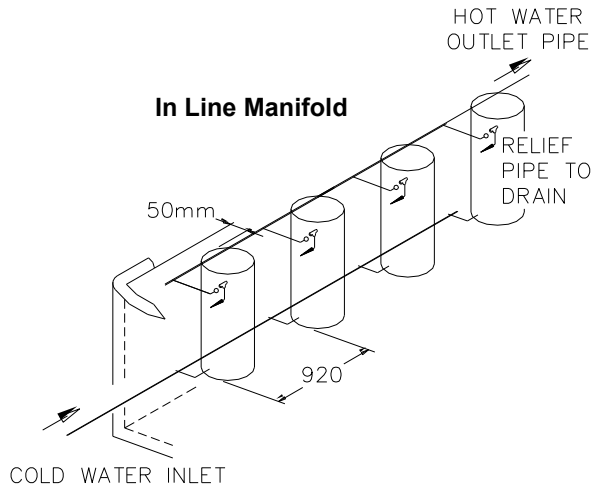

**Single Bank of Water Heaters**

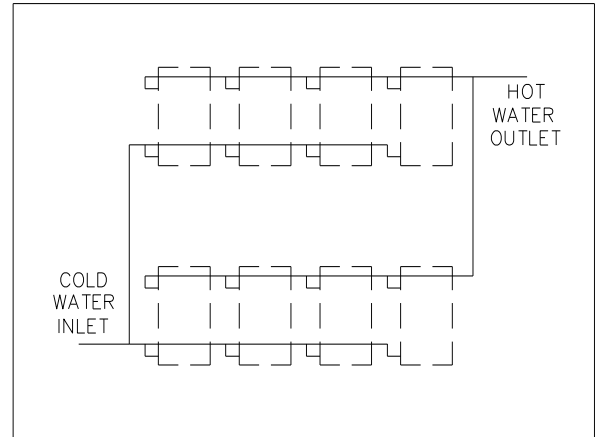
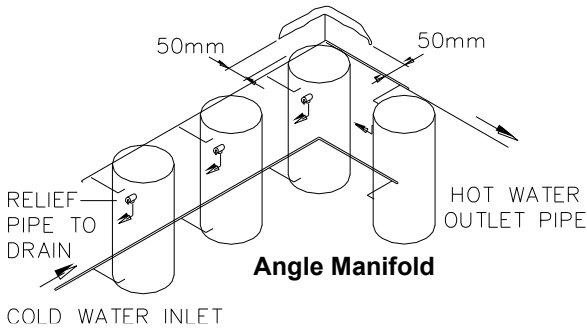

**Multiple Banks of Water Heaters**

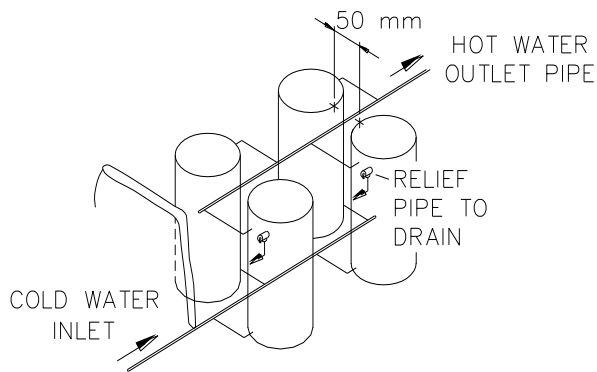

**Back to Back Manifold**

FIX ALL PIPES SECURELY IN POSITION CENTRALLY OVER TUNDISH

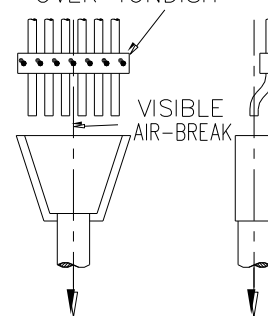

TO FINAL DISCHARGE OUTSIDE BUILDING IN ACCORDANCE WITH REQUIREMENTS OF LOCAL AUTHORITIES.

**TPR Valve Drain Line Common Discharge Point**



**TYPICAL INSTALLATION – RHEEM HEAVY DUTY GAS WATER HEATERS**

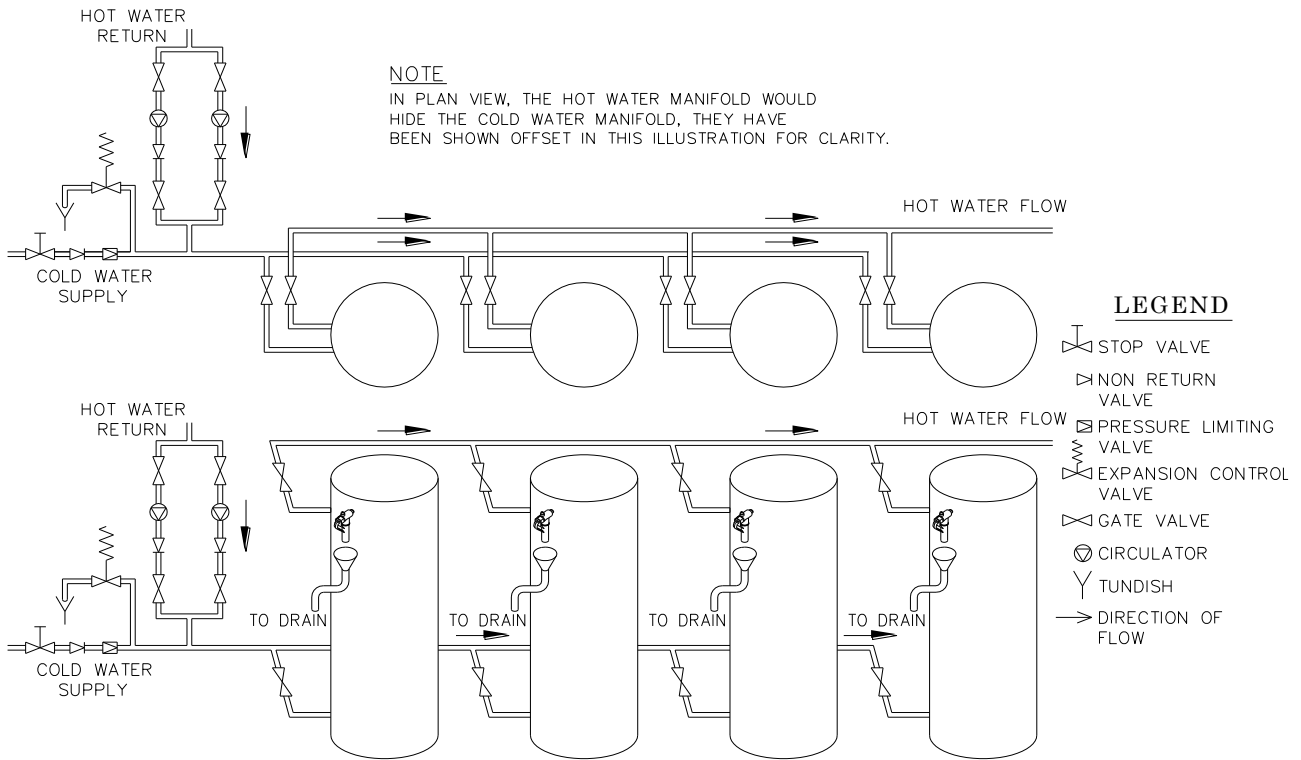

**INSTALLATION DIMENSIONS – RHEEM HEAVY DUTY GAS WATER HEATERS**

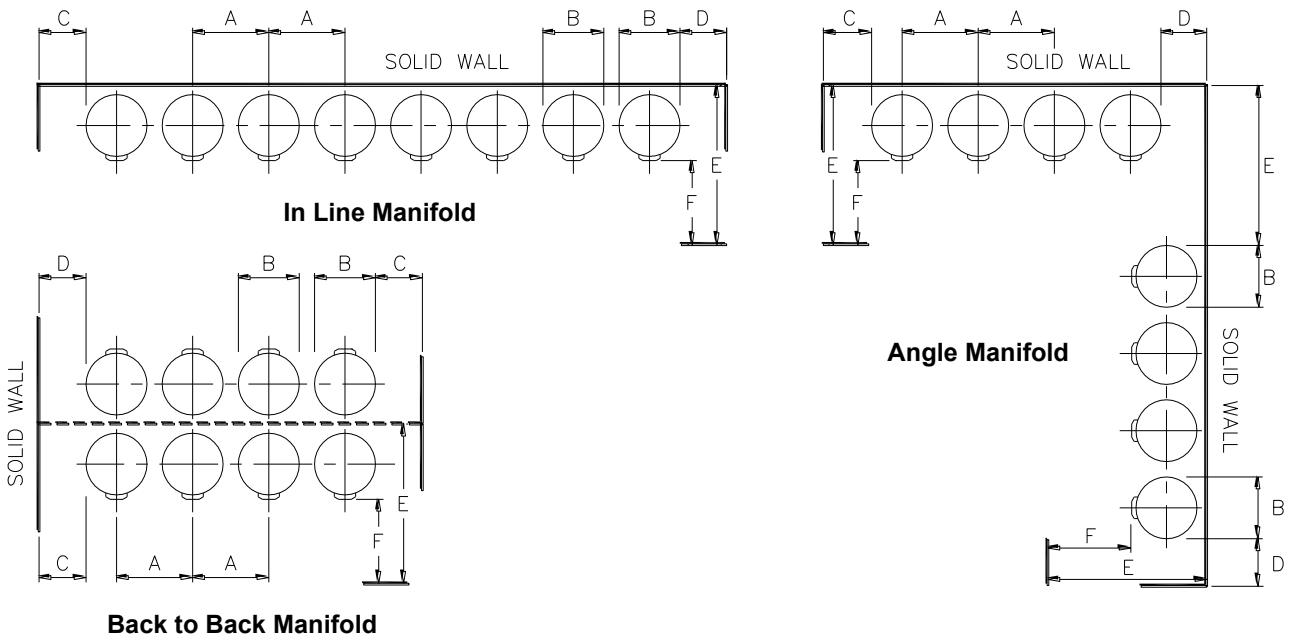

**Notes**

1. A minimum of 900 mm (E\* & F\*) should be left in front of the water heater for access, servicing and water heater removal.
2. Minimum recommended space between wall and back of water heater is 100 mm.

| Installation Layout Minimum Dimensions |     |     |     |     |      |     |
|--|-----|-----|-----|-----|------|-----|
| Model                                  | A   | B   | C   | D   | E*   | F*  |
| 620 260                                | 845 | 595 | 300 | 100 | 1670 | 900 |
| 630 260                                | 920 | 595 | 420 | 420 | 1670 | 900 |

**MANIFOLD ARRANGEMENT**

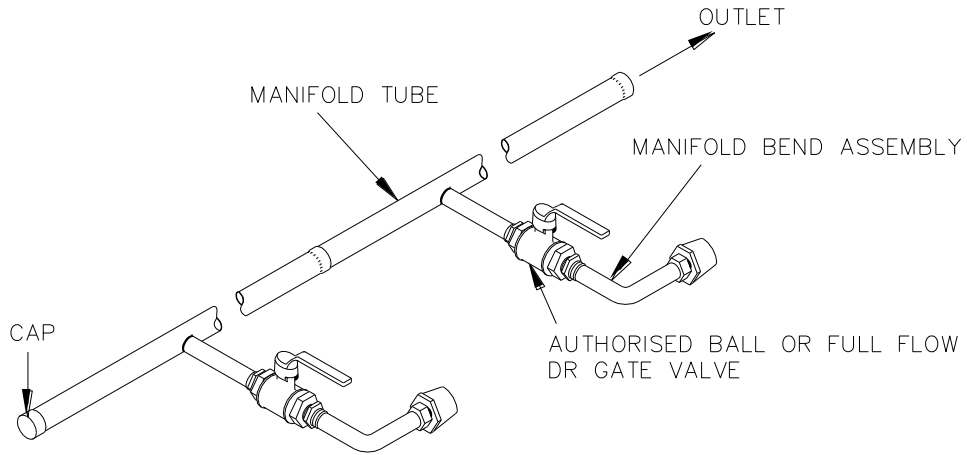

**Hot Manifold Assembly**

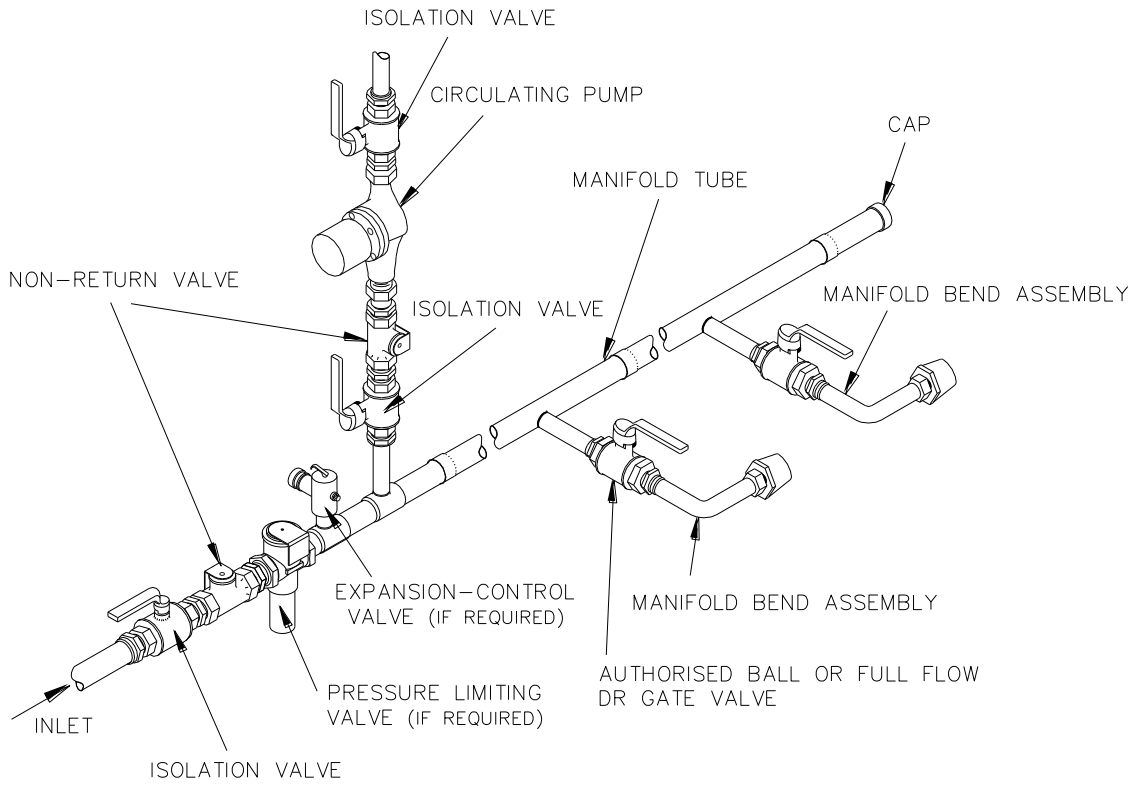

**Cold Manifold Assembly**

---

# COMMISSIONING

---

## TO FILL AND TURN ON THE WATER HEATER

The gas pilot or burner must not be lit until the water heater is filled with water.

- Open all of the hot water taps in the building (don't forget the showers) and supply cock(s) and valve(s) in the system.
- Open the isolation valves fully on the cold and hot water branches to the water heater(s) installed in a bank.
- Open the cold water isolation valve on the cold water line to the water heater(s).

Air will be forced out of the taps.

- Close each tap as water flows freely from it.
- Check the pipe work for leaks.
- Inspect for leaks at the temperature pressure relief valve connection to the water heater.

If a leak is detected, close the cold water isolation valve fully and relieve pressure from the water heater by either operating the easing lever on the temperature pressure relief valve or opening a hot tap. Remove the valve and all of its thread sealant from the threads of the valve. Reapply new thread sealant and refit the valve. Refer to the procedure in ["Temperature Pressure Relief Valve"](#) on page 29.

- Operate the easing lever on the temperature pressure relief valve to check the smooth operation of the valve plunger and that water discharges freely from the drain line. It is very important the lever is raised and lowered gently. The lever should move smoothly and without undue force.

If the lever cannot be moved or is jerky in its movement, then the valve has been damaged and must be replaced.

- Open the gas isolation valve(s) fully.
- Check the gas pipe work for leaks.
- Light the water heater(s) (refer to ["Lighting the Water Heater"](#) on page 36).
- Check the pipe work again for leaks, when the system has reached its working temperature.

**⚠ Warning:** Upon completion of the installation and commissioning of the water heater, leave this guide with the householder or a responsible officer. **DO NOT** leave this guide inside of the cover of the water heater, as it may interfere with the safe operation of the water heater or ignite when the water heater is turned on.

Explain to the householder or a responsible officer the functions and operation of the water heater.

## GAS INLET PRESSURE

**IMPORTANT – CHECK** the gas supply pressure at the inlet to the water heater with the water heater and all other gas burning appliances in the premises operating (burners alight). The minimum gas supply pressure is:

|             |          |         |          |
|-------------|----------|---------|----------|
| Natural Gas | 1.13 kPa | Propane | 2.75 kPa |
|-------------|----------|---------|----------|

If this minimum cannot be achieved, it may indicate the meter or the gas line to the water heater is undersized. It is important to ensure that an adequate gas supply pressure is available to the water heater when other gas burning appliances, on the same gas supply, are operating.

### TO TURN OFF THE WATER HEATER

If it is necessary to turn off the water heater on completion of the installation, such as on a building site or where the premises is vacant, then:

- Shut down the gas control (refer to “Close Down Procedure” on page 38).
- Close the gas isolation valve(s) at the inlet to the gas control(s).
- Close the cold water isolation valve on the cold water line to the water heater(s) to shut down the entire system, or;
- Close the isolation valves on the cold and hot water branches to shut down an individual water heater in a bank.

---

## LIGHTING THE WATER HEATER

---

### FOR YOUR SAFETY READ BEFORE LIGHTING

**⚠ Warning:** This gas water heater is designed to operate reliably and safely as long as the operating instructions are followed **exactly**. You must comply with these lighting instructions at every stage.

**Make sure the water heater is filled with water and the water supply is on, otherwise serious damage to the vitreous enamel cylinder lining and plastic components may occur.**

The installer must check all gas connections for leaks, gas supply pressure and test point pressure (refer rating label).

**Note:** Australian Standard AS 3498 and New Zealand Building Code Clause G12 requires that a water heater provides the means to inhibit the growth of Legionella bacteria in potable water. This water heater can satisfy these AS 3498 and Clause G12 requirements provided it is operating and the thermostat setting is 60°C or higher, including when it is used as an in-series booster water heater for a solar water heater.

### SAFETY INFORMATION

- A. This water heater is equipped with an igniter button which lights the pilot. When lighting the pilot follow these instructions exactly.
- B. **Before lighting** ensure there is no smell of gas around or in the vicinity of the water heater and the burner opening. Be sure to smell next to ground level as some gases can settle there.
- C. What to do if you smell gas.

Do not try to light the water heater.

If the gas smell is throughout the area, turn the gas control knob clockwise to the “●” (off) position and then turn off the isolation valve on the gas line to the water heater. Leave the area and call Rheem Service or their nearest Accredited Service Agent / Centre or a qualified service technician.

- D. Use only your hand to turn the gas control knob, never use tools. If the control knob will not turn by hand, don't try to repair it, call Rheem Service or their nearest Accredited Service Agent / Centre or a qualified service technician. Force or attempted repair may cause a fire or explosion.
- E. Do not attempt to operate this water heater if it has been damaged. Call Rheem Service or their nearest Accredited Service Agent / Centre or a qualified service technician.

**LIGHTING INSTRUCTIONS**

Using the gas control light the water heater as follows:

1. **Stop**, read the [safety information](#) on page 36.
2. Remove the access cover of an outdoor model.
3. Turn the gas control knob fully clockwise to the “●” (off) position.
4. Remove the front cover below the gas control of an indoor model.
5. Wait five (5) minutes so any build up of unburnt gas can escape. If you then smell gas, stop and follow “C” in the safety information. If you do not smell gas, proceed to step 6.
6. Turn the knob to the “✱” (pilot) position.
7. Depress the knob fully (until star disappears below housing) and after 30 seconds, whilst keeping the knob depressed, repeatedly press the igniter button (for up to 40 seconds) until the pilot flame ignites.

**⚠ Warning:** Keep your face clear of the combustion chamber opening while pressing the igniter.

**Note:** It is not possible to depress the knob fully if the gas control has activated its safety shut-off feature. In this case, wait 60 seconds for the gas control to reset.

8. Keep the knob depressed for 20 seconds after the pilot flame lights.
9. Release the knob and check the pilot is still alight. The pilot can be checked by looking through the large opening below the gas control.
10. If the pilot has failed to light or has not remained alight, turn the gas control knob to the “●” (off) position. Wait five (5) minutes for any unburnt gas to escape and then begin again at step 6.

**⚠ Warning:** Failure to wait five (5) minutes may result in a fire or explosion.

11. When the pilot flame remains alight with the gas control knob released, turn the knob anticlockwise to the setting of ‘6’. This will give a water temperature of about 60°C.

If this water heater is installed as an in-series booster water heater as part of a commercial solar water heating system, then Rheem recommends the thermostat is set at 60°C to maximise solar contribution.

12. Refer to [“Temperature Adjustment”](#) on page 11, if further temperature adjustment is required.
13. Replace securely the access cover of the outdoor model or the front cover of the indoor model.

The main burner will now automatically ignite when heating is required and extinguish when the water has been heated to the set temperature. If the main burner does not light at the selected setting, the water may already be at the selected temperature.

**Note:** Never press the igniter button while the top knob is in a numbered position.

### TEST THE WATER HEATER AFTER INSTALLATION

- The operation of the water heater must be thoroughly checked by the installer.
- The burner flame must light smoothly and quickly from the pilot flame, and must go out quietly and completely.
- The main burner flame must be stable, although slight lifting at the front edge of the burner is acceptable when the burner is cold.
- The main burner flame should be blue, with a clearly defined inner cone - luminous yellow or "floating" flames are not acceptable, and must be corrected by opening the air shutter (refer to "Air Shutter" on page 38).
- Check the test point pressure and compare with the rating label. The pressure regulator is not adjustable and if the test point pressure is not within 5% of the specified value, refer to Rheem Service or their nearest Accredited Service Agent / Centre.
- If unable to get the water heater working properly, contact Rheem Service or their nearest Accredited Service Agent / Centre.
- When satisfied everything is working properly instruct the user in the correct method of operation.

### AIR SHUTTER

The air shutter is a hinged flap in the burner aeration tube. It may require adjustment on installation.

- For a Propane model, the air shutter should be fully open.
- The shutter is held in place by a screw on the side of the burner aeration tube.

**Note:** A Natural gas model does not have an air shutter.

### CLOSE DOWN PROCEDURE

1. Turn the gas control knob to the "★" position (pilot). This setting will leave the pilot flame alight however the main burner will not be able to light.
2. Turn the gas control knob to the "●" (off) position. This setting shuts the gas control down completely.

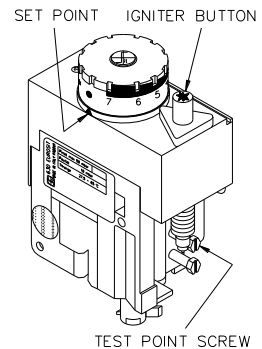

---

## DRAINING THE WATER HEATER

---

 **Warning:** Exercise care, as water discharged from the water heater may be of a very high temperature.

To drain the water heater:

- Turn off the water heater (refer to [“To Turn Off The Water Heater”](#) on page 36).
- Close all hot water taps.
- Operate the relief valve lever - do not let the lever snap back or you will damage the valve seat. **It is very important the lever is raised and lowered gently.**

Operating the lever will release the pressure in the water heater.

- Attach a hose to the water heater drain cock.

Let the other end of the hose go to a drain.

- Open the drain cock.
- Open the relief valve by holding the lever in the raised position.

This will let air into the water heater and allow the water to drain through the hose.

