



RHEEM MPI-325 SERIES II HEAT PUMP

EFFICIENT HEAT PUMP
WITH POWERFUL
BOOST ELEMENT

RHEEM MPI-325 SERIES II HEAT PUMP

The Rheem MPI-325 Heat Pump is recommended for replacement of small to medium electric water heaters in Zone 1 to 4. It utilises environmental heating technology to efficiently heat water. Free, renewable heat energy is absorbed and processed through a refrigeration system, resulting in hot water using a third of the energy of an electric water heater.



FEATURES

- Multi-pass heating – Heats the water ‘isothermally’ by passing the water through the heat exchanger multiple times
- Constant recovery – Minimises energy use by heating at a ‘constant’, optimised rate
- One plumber installation – Two piece system configuration allows single plumber installation
- Energy efficient – Can save up to 65% on your water your water heating energy consumption compared to an electric water heater in Zone 3^{2,3}
- No Solar Panels – No structural load on your roof and looks better too
- Back-up element – 3.6 kW boost element provides frost protection. Designed to be activated only during very cold conditions, this feature ensures you have hot water available when required
- Whisper technology – Enables quieter operation
- LED Display – Enables you to easily check the operating status of the water heater
- Eligible for STCs (may be eligible for additional incentives in some states)
- 5 year cylinder warranty⁴

WHY CHOOSE A RHEEM HEAT PUMP?

- Works day and night, as they don’t rely on sunlight to operate
- Similar efficiency to traditional electric boosted solar systems
- Frost protected
- Offers a back-up element as standard, delivering hot water, even on the coldest winter nights
- Manufactured in Australia

COP¹ – The Coefficient of Performance for a Heat Pump is the ratio of how much useful heat it produces for water heating to the power input into the water heater. The higher the COP number, the more efficient the Heat Pump is.

Ambient Air Temperature and Humidity – The performance of a Heat Pump changes with ambient air temperature, humidity and incoming water temperature. The warmer the air temperature, the higher the Relative Humidity and the cooler the water temperature, the higher is the heating rate of the Heat Pump. Performance specifications stated in relation to the Heat Pump are measured at predefined conditions during its testing.

Average Heating Capacity (kW) – This is how much heating power is put into the water during the heating cycle. It is expressed as an average due to the changes in heating power from the refrigeration cycle as the water is being heated and its temperature increases during the heating cycle.

Hot water Recovery Rate @ 45°C rise (L/hr) – Is the number of litres of water that can be heated through a 45°C temperature rise in one hour, e.g. when the air temperature is 19°C, the Heat Pump can heat 56 litres / hours of water @ 45°C rise.



**RHEEM MPI-325
SERIES II HEAT PUMP**





RHEEM MPI-325 SERIES II HEAT PUMP

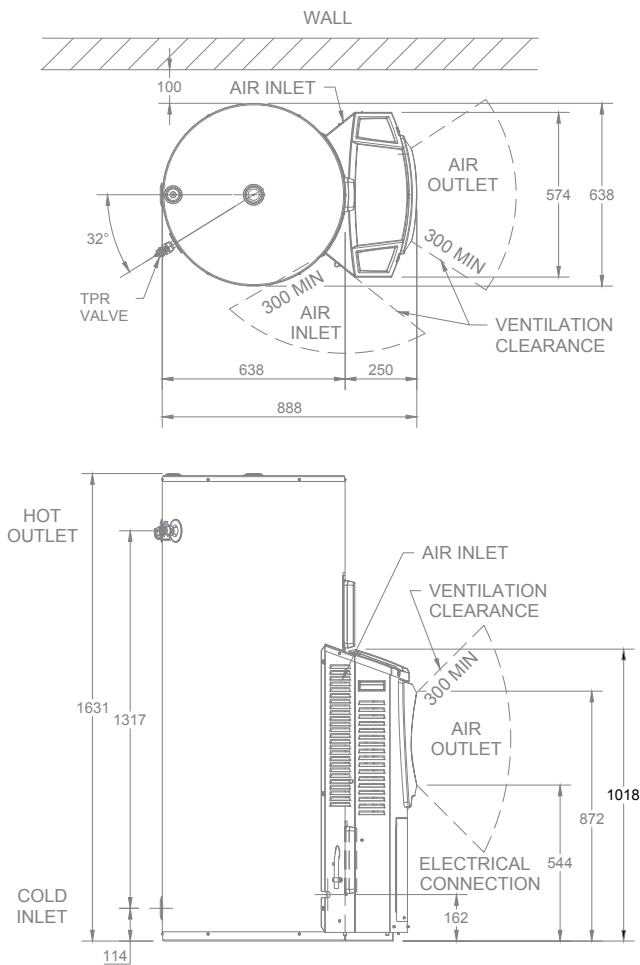

RHEEM MPI-325 SERIES II HEAT PUMP

MODEL	UNIT	551325
Storage capacity	Litres	325
Boost capacity	Litres	180
Rated Heat Pump Power input	Watts	800
Element rating	kW	3.6
Recommended electrical circuit	Amps	15
Coefficient of Performance (@ 19°C) ¹	COP	3.6
Noise Level @ 1 metre ⁵	dB(A)	52
People per household ⁶		Up to 5

Dimensions & specifications		
Tank height	mm	1631
Tank width	mm	863
Tank depth	mm	638
Heat Pump Module weight	kg	42
Tank weight – empty	kg	88
Refrigerant		R134a

Water connections & Pressure settings		
Inlet & Outlet	RP	3/4/20
Temperature Press Relief (TPR) Valve setting	kPa	1000
Expansion Control Valve (ECV) setting	kPa	850
Maximum mains supply pressure		
With Expansion Control Valve	kPa	680
Without Expansion Control Valve	kPa	800

HEAT PUMP PERFORMANCE SPECIFICATIONS 551325

Ambient air temperature	Relative Humidity	Average heating capacity (kW)	Recovery Rate @ 45°C rise (L/hr)	Average Coefficient of Performance (COP) ¹
7°C	86%	1.5	28	2.8
19°C	65%	1.9	36	3.6
33°C	35%	2.5	47	4.2
33°C	59%	2.6	50	4.5

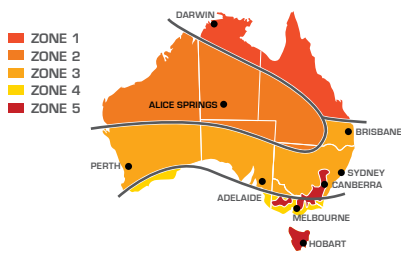

STCs

Small-scale Technology Certificates (STCs) provide a financial incentive to encourage the installation of Solar and Heat Pump water heaters provided under a Federal Government legislated scheme.

This map shows the climate Zones within Australia which will define the number of STCs allocated to an approved Heat Pump water heater. Your installation may be eligible for additional incentives in some states. See website for details.

For more information on STCs visit www.rheem.com.au/rheem/help/offers-and-incentives/stcs

- The COP of 3.6 is the average value in the AS/NZS5125 performance test at 19°C ambient temperature over the entire heat-up process. Note that the actual COP of the product at any given time will be impacted by a number of factors, including the ambient and cold-water inlet temperatures at the place of installation and time of day/season of operation.
- Energy savings of up to 65% are based on Australian Government approved TRNSYS simulation modelling using a medium load in Zone 3 and apply when replacing an electric water heater of similar size with a Rheem 551325 Heat Pump water heater. Any savings will vary depending upon your location, type of water heater being replaced, hot water consumption and fuel tariff. Before installation - seek advice as to suitability to household usage and tariffs. The impact on an electricity account will depend on the tariff arrangement of the water heater being replaced and where you live.
- This Heat Pump water heater (climate dependent) is recommended for connection to either a 24 hour continuous tariff or an extended off-peak (min. 16 hours/day). If replacing an electric water heater greater than 160 litres, Heat Pump connection to a 24 hour continuous tariff is recommended. Before purchase consult your energy provider for more information on cost comparisons.
- Warranty Periods: 5 years supply on cylinder, 3 years labour on cylinder, 2 years supply on sealed system including labour, 1 year supply and labour on all other parts. Applies to a single-family domestic dwelling only. Conditions apply. See the Rheem warranty set out in the Owner's Guide and Installation Instructions or view at www.rheem.com.au/warranty
- Noise Level – A noise level of 52 dB(A) was measured at 1 m from the water heater during a Noise Test conducted to Standard GB/T 23137-2008 in a hemi-anechoic chamber within a laboratory. The noise level when installed may be higher due to sound reflections from adjacent walls and structures.
- No. of people recommended based on 7 min showers @ 42°C. Appliances using hot water should be counted as one (1) person.

®Registered Trade mark of Rheem Australia Pty Ltd. ™ Trade mark of SAI Global. A Greater Degree of Good is a Trade mark of Rheem Manufacturing Company. Materials and specifications are subject to change without notice.



A Greater Degree of Good™ represents our global commitment to sustainability.



Rheem Australia Pty Ltd.
1 Alan Street, Rydalmere,
NSW 2116 Australia
PO Box 7508, Silverwater
NSW 2128 Australia
www.rheem.com.au



RHE536-MAY2024-BELONG

COMES ON STEADY, HOT AND STRONG

INSTALL A

