

TOP VIEW

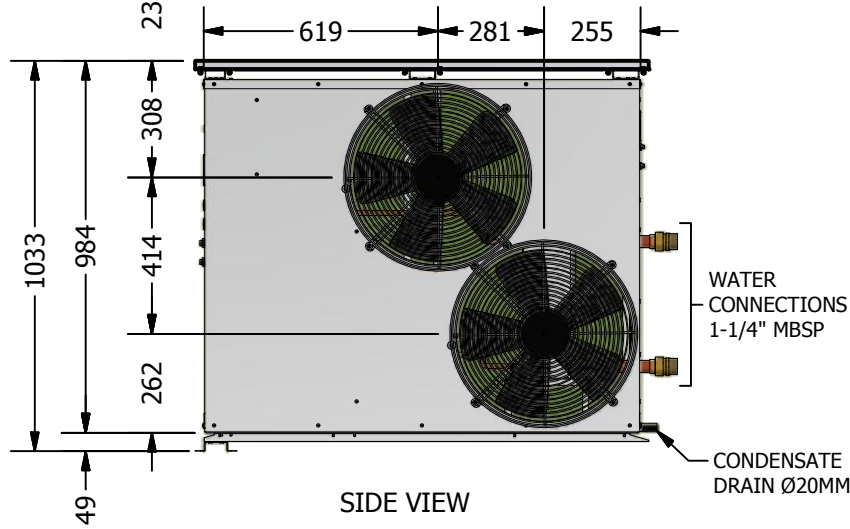

SIDE VIEW

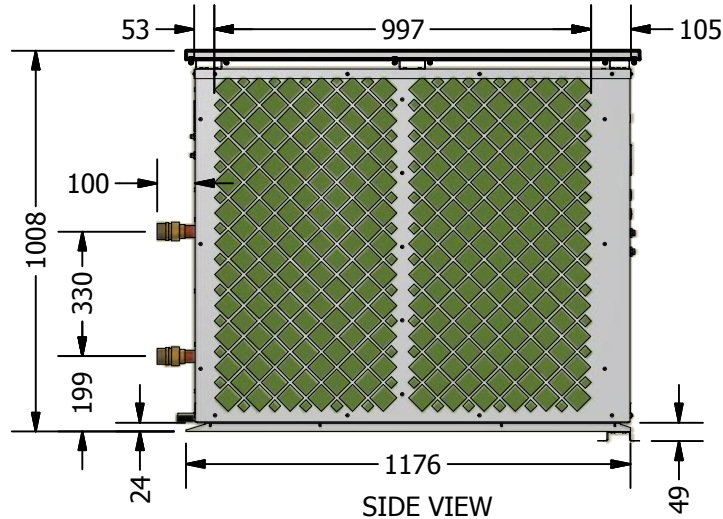

SIDE VIEW

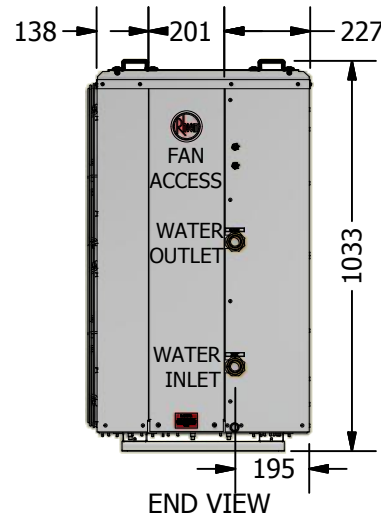

END VIEW



END VIEW

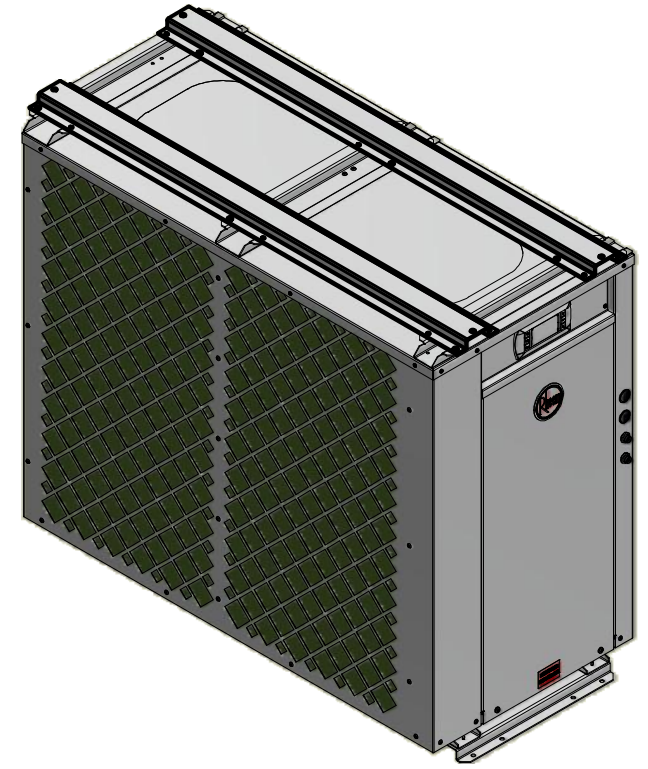

REV	ECN	DESCRIPTION	DATE
1	0326	WATER CONNECTIONS DIM 195 WAS 123. ITEM 1,2,3 UPDATED	18/12/18
2	0336	WATER CONNECTIONS DESCRIPTION CORRECTED	02/04/19
3	0345	ITEM 1 & 3 S/M AND ELEC BOX UPDATED	14/06/19

 Rheem THERMAL SYSTEMS GROUP		SHEET 1 OF 3	
Description:	RHEEM HP COMM EXT 16kW R134A		
Part No:	953016HS	Rev.	3
Material:		Date:	13/09/2018
Drawn By:	jbates	Checked By:	
General Tolerance:	Sheetmetal - Cut Size - ± 0.5mm, Angle - ± 0.5°, Bend size - ± 0.3mm Tubes - Dimensions ± 2, Angle ± 2°		Scale: N.T.S

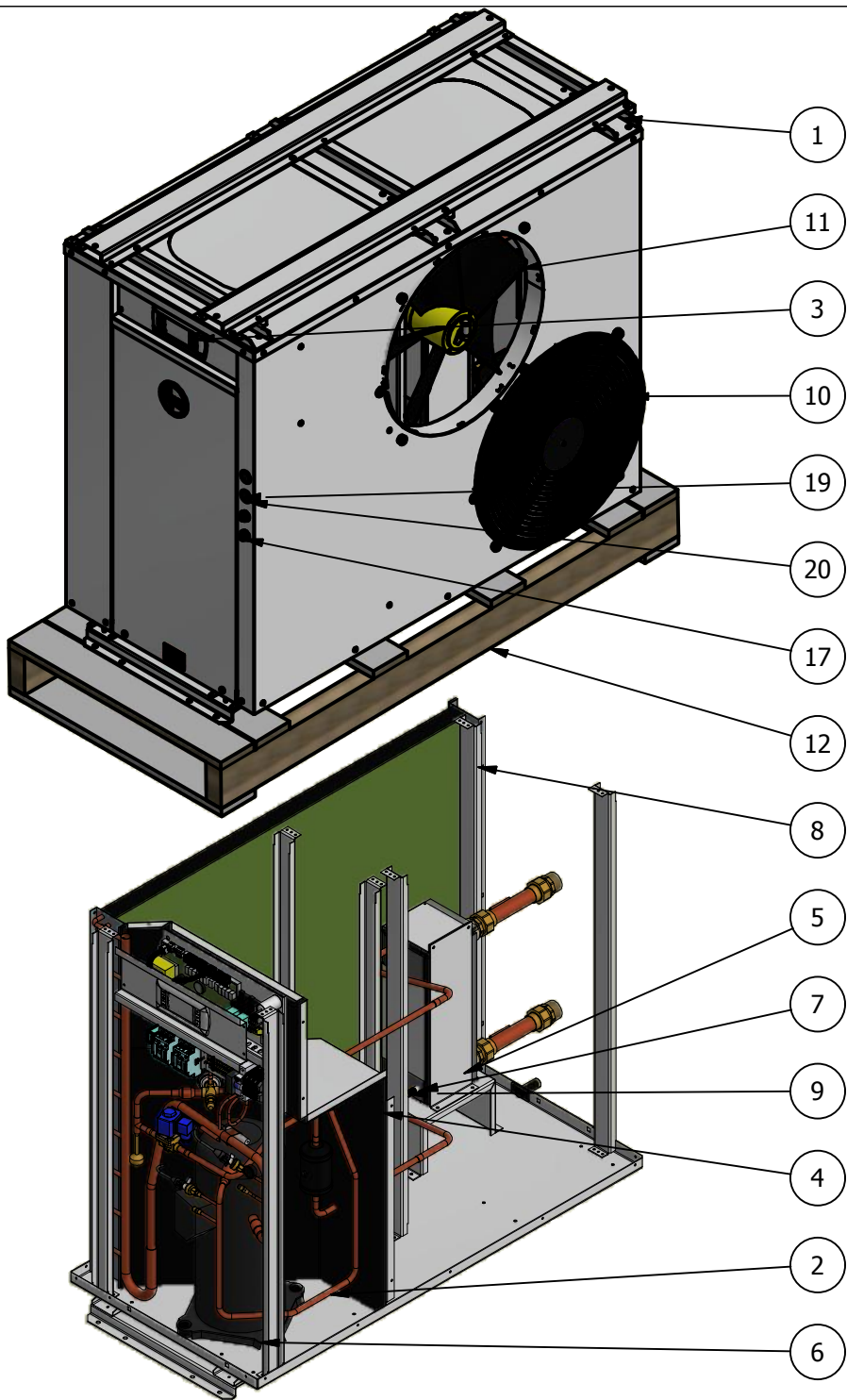

ITEM	QTY	PART NUMBER	DESCRIPTION
			ASSEMBLIES
1	1	45053	SHEET METAL ASSEMBLY- 953016HS
2	1	46055	PIPE ASSY - 95#016H#
3	1	47062	ELECTRICAL ASSY - 953016H0/953016HS
4	1	48007	INSULATION ASSEMBLY - 95#016##
5	1	26426	Pre-Cut Insulation H/Exchan
			MAIN PARTS
6	1	20014	ZR81KCE-TFD-522 22kW 3 phase R22/R407c
7	1	16835	B16HDWx52/1P-SC-M Heat Exchang
8	1	16926	Condenser Coil E7-3493 AC18 LH
9	1	16834	Pressure Relief Valve 04-38888-00
10	2	16116P	Fan Guard 450mm #Painted
11	2	21018	A6E450-AJ08-11 450mm flat fan no guard
12	1	16372	Pallet 1360 x 630mm
13	1	17291	0-17.3B Ratiometric Press. Sensor
14	1	17407	0-34 bar 0-5 v Ratiometric Press.
15	2	17292	Sensor Cable 2m SPKC002310
16	1	16906	Solenoid valve coil MQ-A0322G-000001
17	1	17467	Amphenol Mini Screw 2 by 3Pin F Socket with 1M
18	2	17465	Amphenol Mini Screw 2Pin F Socket with 1M Cable
19	2	26429	Dome Plug, DP-750
20	2	26570	Snap Bush, 25mm, SB-1.00-12
21	2	26048	Grommet,MO101 Suits 3/4" - 7/8"
			SENSORS AND BULBS
22	1	16746	TXV 13kW/3.5T BULB
23	4	17289	NTC Temp. Sensor 1.5m NTC015HP00





Rheem

THERMAL SYSTEMS GROUP

SHEET 2 OF 3

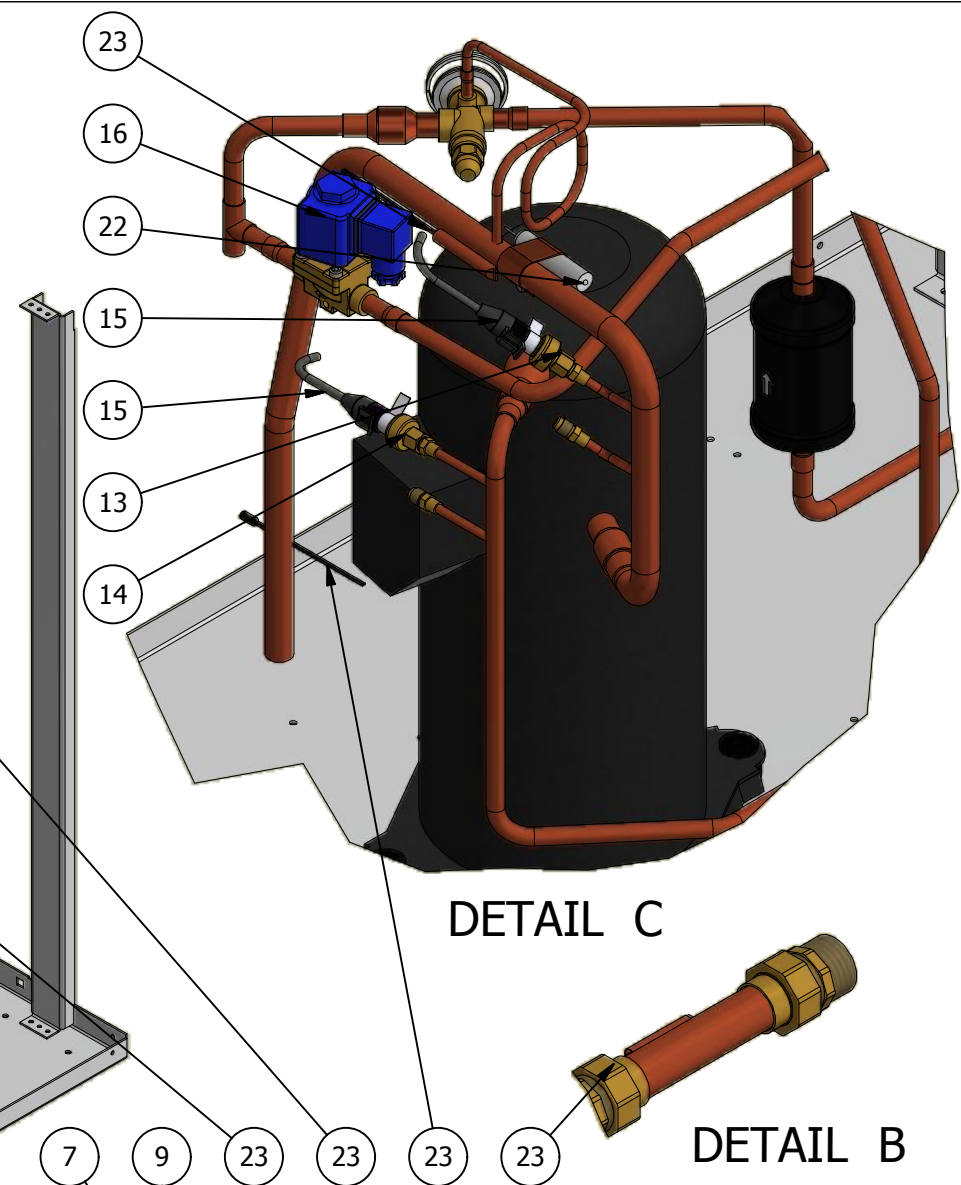
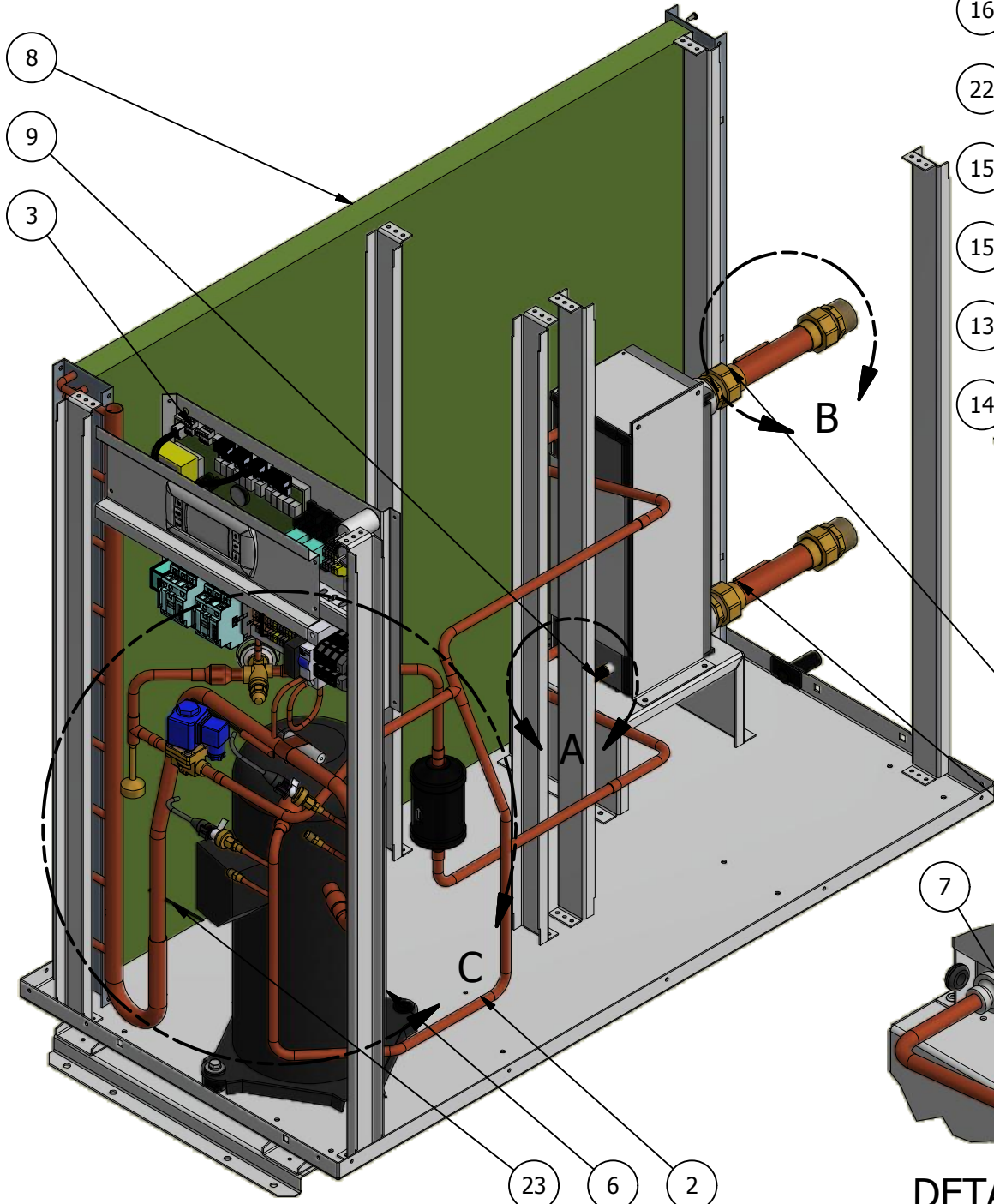
Description:	RHEEM HP COMM EXT 16kW R134A		
Part No:	953016HS	Rev.:	3
Material:		Date:	13/09/2018
Drawn By:	jbbates	Checked By:	
General Tolerance:	Sheetmetal - Cut Size - ± 0.5mm, Angle - ± 0.5°, Bend size - ± 0.3mm Tubes - Dimensions ± 2, Angle ± 2°		Scale: N.T.S



 Rheem THERMAL SYSTEMS GROUP		SHEET 3 OF 3	
		Description: RHEEM HP COMM EXT 16kW R134A	
Part No:	953016HS	Rev.	3
Material:		Date:	13/09/2018
Drawn By:	jbbates	Checked By:	
General Tolerance:	Sheetmetal - Cut Size - $\pm 0.5\text{mm}$, Angle - $\pm 0.5^\circ$, Bend size - $\pm 0.3\text{mm}$		Scale: N.T.S
	Tubes - Dimensions ± 2 , Angle $\pm 2^\circ$		