

Features & Benefits

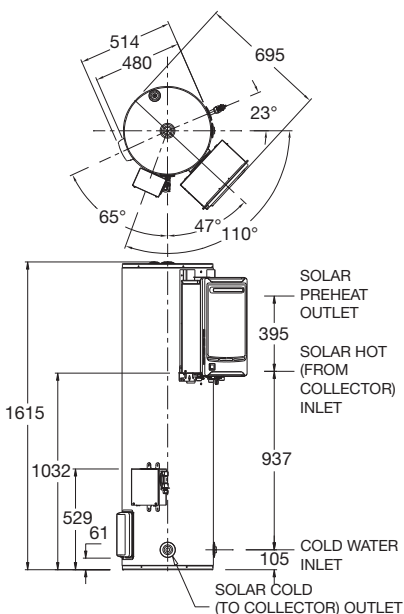

- Split system design – vitreous enamel lined cylinder installed at ground level
- Limited frost protection⁴
- 26 L/min in-series gas booster site integrated or Rheem 27L/min in-series gas booster installed remotely
- Suitable with CSA2612 collector (VIC & SA) or 2 LCS collectors (VIC only)
- Eligible for STCs⁵
- 5 year cylinder warranty¹



MODEL	511161
Storage Capacity (L)	165
Solar Collectors (VIC or SA)	1 CSA2612
Solar Collectors (VIC only)	2 LCS
Booster Type	Gas
Weight Empty (kg)- Tank without booster	62
Weight Empty (kg)- Tank with booster	81
Tank Water Connections	Rp ³ / ₄
Gas Booster Water Connections	R ³ / ₄
Gas Connection	R ³ / ₄



Scan code for details & installation instructions

