



RHEEM PREMIER® LOLINE SOLAR WATER HEATER

	1 - 5	270L	5 YEAR
SOLAR	PEOPLE <small>(See Table)</small>	CAPACITY	WARRANTY*



MODEL NO.
596270/2S

FEATURES

- **Complete Frost Protection** – Unique Drain-Back™ heat exchange technology protects in any weather extreme
- Available in a 270L capacity
- **Hard Water Tolerance** – suitable for use with most water quality types
- **Visual Appeal** – split systems only require slimline panels to be mounted on the roof and feature a ground mounted tank. This reduces structural load on your roof, and looks better too
- **Energy Efficient** – cuts energy use by up to 70%^{1,2}
- **Booster** – choice of 5 star continuous flow gas boost or electric element back up to provide hot water in any weather condition
- Full Mains Pressure for multiple outlets simultaneously³
- Internally mounted pump and controller
- Low maintenance ground level tank
- **LED Display** – enables you to easily check the operating status of the water heater
- Top mounted solar connections are located safely out of reach of children
- Eligible for RECs, and State and Federal Government Rebates**
- 5 year warranty*



MODEL NO.
591270/2S



FROST PROTECTION

Specifically designed for environments prone to frost, the Rheem Premier Loline incorporates Drain-Back™ heat exchange technology to maximise solar gain and protect against all weather extremes. The Premier Loline replaces water in the panels with a special heat exchange fluid with anti-freeze properties. The design is both safe and efficient, as fluid drains out of the panels to prevent freezing and heat loss in cold conditions, and overheating in hot climates.

BOOSTER OPTIONS

The 270 litre Premier Loline offers on-site integrated and remote gas boosting or in-tank electric boost options.

Gas boost models incorporate a 27L/min 5 star continuous flow water heater providing outstanding backup on cloudy days.

The electric model is suitable for connection to a continuous tariff and features automatic electronic controls.



INSTALL A RHEEM®





RHEEM PREMIER LOLINE SOLAR WATER HEATER

GAS

ELECTRIC

MODEL		596270/1S	596270/2S	590270/1S-G	590270/2S-G	591270/2S	591270/3S
Storage Capacity	L	270	270	270	270	270	270
Solar Panels	S200	1	2	1	2	2	3
Booster Type		Gas – Integrated	Gas – Integrated	Gas – Remote	Gas – Remote	Electric	Electric
Boost Capacity	L	27L/min	27L/min	27L/min	27L/min	125	125
People Per Household		2-5	2-5	2-5	2-5	1-3	2-4
Dimensions & Specifications							
Height (A)	mm	1775	1775	1775	1775	1775	1775
Width (B)	mm	648	648	648	648	648	648
Depth (C)	mm	888	888	682	682	682	682
Weight Empty – Tank	kg	165	165	145	145	146	146
Weight Full – Tank	kg	435	435	415	415	416	416
Weight Empty – Solar Panels	kg	35	70	35	70	70	105
Weight Full – Solar Panels	kg	37	74	37	74	74	111

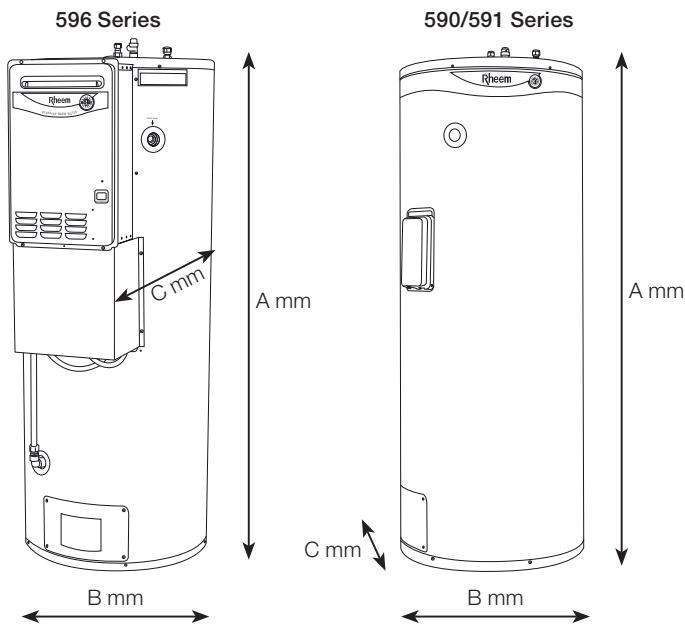

SOLAR PANEL	A	B	C
S200 & T200	1022	1937	65

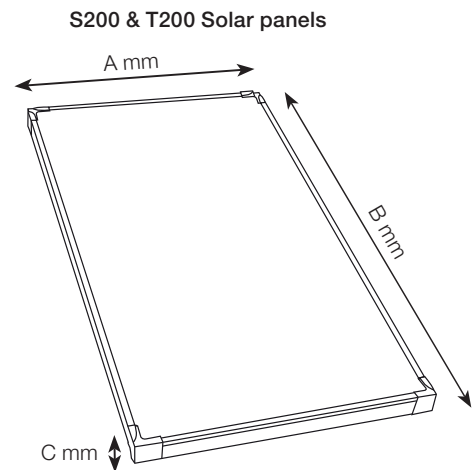

RECs

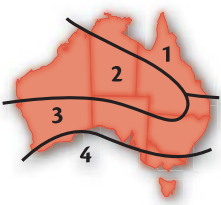

Renewable Energy Certificates (RECs) are a financial incentive to encourage the installation of solar water heaters that is provided under a Federal Government operated scheme.

The table shows the number of RECs that Rheem Premier Loline is eligible for in each of the four zones across Australia. To claim your REC entitlement, simply complete the REC assignment form that can be downloaded from the Rheem SolarSavers™ Website, www.rheemsolarsavers.com.au



Other Federal and State Government rebates may also apply.

* **Warranty Conditions.** 5 year cylinder, heat exchanger and solar panels, 3 year labour on cylinder and heat exchanger, 1 year parts including labour. Applies to domestic installations only.

† 591270 should be used with T200 solar panels in Victoria and South Australia.

‡ Energy reduction of up to 70% based on Australian Government Approved TRNSYS simulation modelling and apply when replacing an electric water heater with a Rheem solar water heater in zone 3.

§ Any financial savings will vary depending upon type of Rheem Solar system installed, orientation and inclination of the solar collectors, type of water heater being replaced, hot water consumption and fuel tariff. Maximum financial savings off your hot water bill are achievable when replacing an electric water heater on continuous tariff.

¶ Electric boost models only.

**Eligibility criteria apply.

Materials and specifications are subject to change without notice.

†† Registered Trademark of Rheem Australia Pty Ltd.

††† Trademark of Rheem Australia Pty Ltd.

RECs	Zone 1	Zone 2	Zone 3	Zone 4
596270/1S	25	27	25	20
596270/2S	35	38	35	29
590270/1S-G	25	27	25	20
590270/2S-G	35	38	35	29
591270/2S	26	27	26	20
591270/3S	29	30	29	23
591270/2T†	29	30	29	24
591270/3T†	32	31	32	27

Additional systems also available. See rheemsolarsavers.com.au for more information.



Rheem Australia Pty Ltd.

1 Alan Street, Rydalmere, New South Wales 2116, Australia
PO Box 6, Rydalmere, New South Wales 2116, Australia.

