



# RHEEM PREMIER® HILINE SOLAR WATER HEATER

	1 - 5	180 - 300 L	6 YEAR
SOLAR	PEOPLE <small>[see table]</small>	CAPACITY	WARRANTY*



MODEL NO. 52H300K/2S



## FEATURES

- **Complete frost protection** – Heat exchange technology protects the system down to freezing -17°C temperatures
- Available in 180L & 300L tank capacities
- **Hard Water Tolerance** – suitable for use with most water quality types
- **Space saving design** – a complete roof mounted installation featuring a durable, lightweight stainless steel tank
- **Energy Efficient** – cuts energy use by up to 70%<sup>1,2</sup>
- **Booster** – choice of 5 star continuous flow gas boost or electric element back up to provide hot water in any weather condition
- **Low maintenance** – with no electronics or pumps required, Premier Hiline will reliably produce efficient hot water day in and day out, in any weather extreme
- Mains Pressure delivers full water pressure to all taps at the same time<sup>3</sup>
- Eligible for RECs, and State and Federal Government Rebates\*\*
- 6 year warranty\*

## WHY CHOOSE PREMIER HILINE?

Rheem Premier Hiline is an indirect solar water heater specifically designed for environments prone to frost and is suitable for use with most water qualities. By using the sun's energy as its primary heating source and heating via the *thermosiphon* principle, it avoids potential maintenance issues with circulating pumps and electronic controllers found on split solar models. Premier Hiline models can also reduce water heating energy consumption by up to 70%<sup>1</sup>.

The range includes both 180L and 300L models, using high efficiency S200 solar panels. The whole system is installed on your roof, saving space and keeping hot pipework well out of reach of young children.

## FROST PROTECTION

Premier Hiline models feature heat exchange technology, maximising solar gain whilst providing frost protection. Rather than directly heating water, special heat exchange fluid flows through the solar panels to capture the sun's energy. With its anti-freeze properties, this fluid will prevent freezing in the solar panels down to -17°C.





# RHEEM PREMIER® HILINE SOLAR WATER HEATER

GAS

ELECTRIC

MODEL		52H180K/1S-G	52H300K/2S-G	52H180K/1S	52H300K/2S
Storage Capacity	L	180	300	180	300
Solar Panels	S200	1	2	1	2
Booster Type		Gas – Remote	Gas – Remote	Electric	Electric
Boost Capacity	L	27L/min	27L/min	90	150
People Per Household		1-3	2-5	1-2	2-5
<b>Dimensions &amp; Specifications</b>					
Height (A)	mm	2490	2490	2490	2490
Width (B)	mm	1220	2030	1220	2030
Depth (C)	mm	620	620	620	620
Weight Empty – Tank	kg	48	68	48	68
Weight Full – Tank	kg	237	386	237	386
Weight Empty – Solar Panels	kg	35	70	35	70
Weight Full – Solar Panels	kg	37	74	37	74

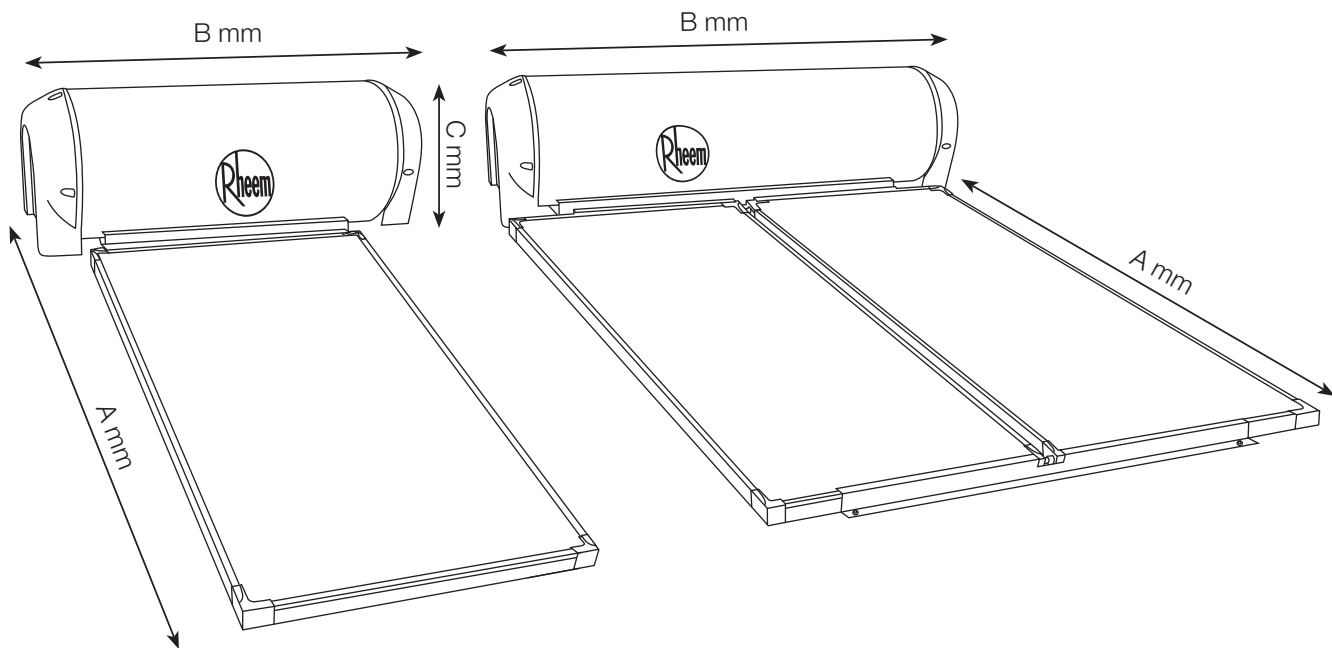

## RECs

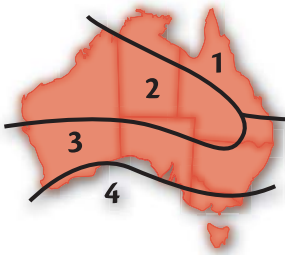

Renewable Energy Certificates (RECs) are a financial incentive to encourage the installation of solar water heaters that is provided under a Federal Government operated scheme.

The table shows the number of RECs that Rheem Premier Hiline is eligible for in each of the four zones across Australia. To claim your REC entitlement, simply complete the REC assignment form that can be downloaded from the Rheem SolarSavers™ Website, [www.rheemsolarsavers.com.au](http://www.rheemsolarsavers.com.au)



Other Federal and State Government rebates may also apply.

RECs	Zone 1	Zone 2	Zone 3	Zone 4
52H180K/1S-G	24	24	24	20
52H300K/2S-G	35	37	35	28
52H180K/1S	16	17	16	12
52H300K/2S	27	28	27	22

\* **Warranty Conditions.** 6 year cylinder, 5 year solar panels, 1 year labour on cylinder, 1 year parts including labour. Amended warranty may apply where a government rebate has been received for the solar water heater. Phone 131 031 for details.

<sup>1</sup> Energy reduction of up to 70% based on Australian Government Approved TRNSYS simulation modelling and apply when replacing an electric water heater with a Rheem solar water heater in zone 3.

<sup>2</sup> Any financial savings will vary depending upon type of Rheem Solar system installed, orientation and inclination of the solar collectors, type of water heater being replaced, hot water consumption and fuel tariff. Maximum financial savings off your hot water bill are achievable when replacing an electric water heater on continuous tariff.

<sup>3</sup> Electric boost models only.

\*\*Eligibility criteria apply.

Materials and specifications are subject to change without notice.

<sup>o</sup> Registered Trademark of Rheem Australia Pty Ltd.

<sup>™</sup> Trademark of Rheem Australia Pty Ltd.

**Rheem Australia Pty Ltd.**

1 Alan Street, Rydalmere,  
New South Wales 2116, Australia  
PO Box 6, Rydalmere,  
New South Wales 2116, Australia



Australian Standard  
AS 2712 LC157  
S41 Global



Quality  
ISO 9001



AS 3498  
WMKA00153

