



RHEEM HILINE SOLAR WATER HEATER

	1 - 5	160 - 300 L	5 YEAR
SOLAR	PEOPLE (See Table)	CAPACITY	WARRANTY*



MODEL NO.
52S300/2NPT



Using the sun's
FREE energy is the
most efficient way
to heat water ...
naturally



FEATURES

- **Space saving design** – a complete roof mounted installation featuring a proven, glass enamel lined tank
- Available in 160L and 300L capacities
- **Energy Efficient** – cuts energy use by up to 70%^{1,2}
- **Booster** – choice of 5 star continuous flow gas boost or electric element back up to provide hot water in any weather condition
- Mains Pressure delivers full water pressure to all taps at the same time³
- **Low maintenance** – with no electronics or pumps required, Rheem Hiline will reliably produce efficient hot water day in and day out.
- Eligible for RECs, and State and Federal Government Rebates**
- 5 year warranty*

WHY CHOOSE HILINE?

Rheem Hiline is a streamlined roof mounted solar system with proven reliability. Designed and manufactured in Australia, the product works via the thermosiphon principal or what we call 'ThermoTech'. This relies on water moving through the solar panel(s) and into the tank using energy absorbed from the sun. As such, it doesn't require a pump and solar controller. And with everything conveniently located on the roof, it frees up usable space at ground level while keeping hot pipe work out of reach of young children.

BOOSTER OPTIONS

The Rheem Hiline range is available with both in-tank electric, and continuous flow gas boosting. Boosting is a back-up feature that provides hot water during poor weather periods.

The electric boosted models will provide a specified boost volume (see table), with larger models designed to suit larger hot water loads. The gas boosted models feature an inline 24L/min continuous flow gas booster, which only turns on to heat water when the water temperature flowing through it is less than 60°C.

INSTALL A RHEEM®





RHEEM HILINE SOLAR WATER HEATER

GAS

ELECTRIC

MODEL		52S160/1NPT-G	52S300/2NPT-G	52S160/1NPT	52S300/2NPT
Storage Capacity	L	160	300	160	300
Solar Panels	NPT200	1	2	1	2
Booster Type		Gas – Remote	Gas – Remote	Electric	Electric
Boost Capacity	L	24L/min	24L/min	80	160
People Per Household		1-3	2-5	1-2	2-5
Dimensions & Specifications					
Height (A)	mm	2452	2452	2452	2452
Width (B)	mm	1070	1865	1070	1865
Depth (C)	mm	540	540	540	540
Weight Empty – Tank	kg	70	95	70	95
Weight Full – Tank	kg	230	395	230	395
Weight Empty – Solar Panels	kg	34	68	34	68
Weight Full – Solar Panels	kg	40	80	40	80

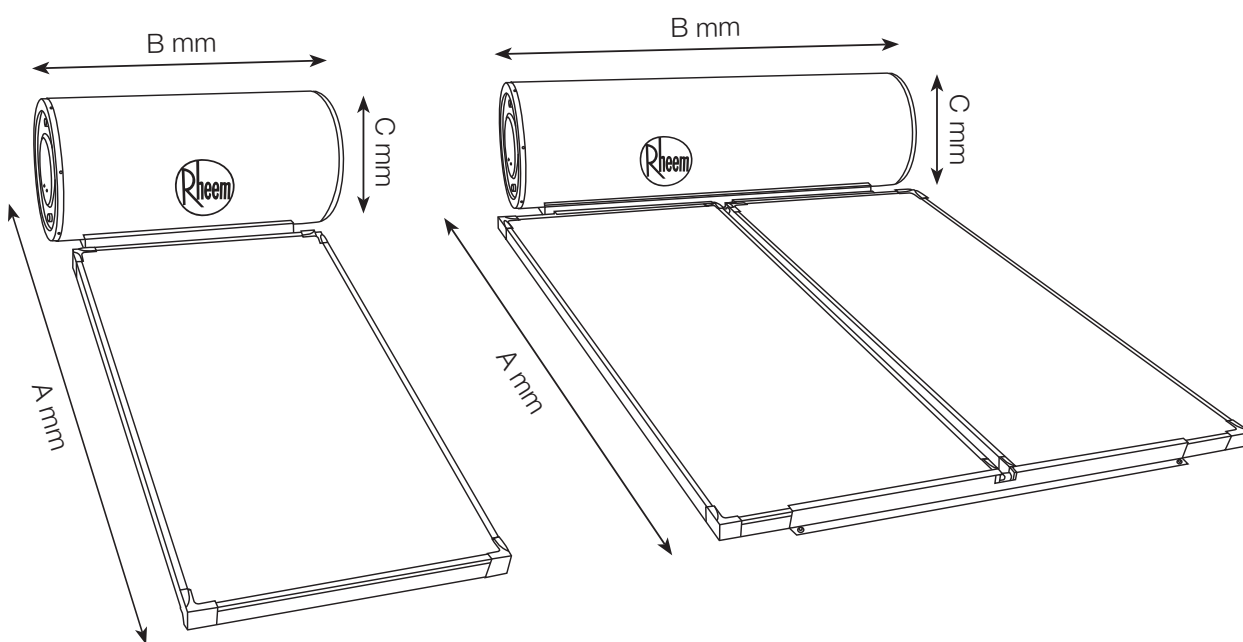

RECs

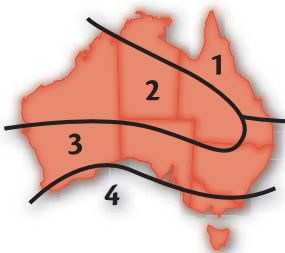

Renewable Energy Certificates (RECs) are a financial incentive to encourage the installation of solar water heaters that is provided under a Federal Government operated scheme.

The table shows the number of RECs that Rheem Hiline is eligible for in each of the four zones across Australia. To claim your REC entitlement, simply complete the REC assignment form that can be downloaded from the Rheem SolarSavers™ Website, www.rheemsolarsavers.com.au



Other Federal and State Government rebates may also apply.

RECs	Zone 1	Zone 2	Zone 3	Zone 4
52S160/1NPT-G	25	24	25	21
52S300/2NPT-G	38	39	38	32
52S160/1NPT	15	16	15	11
52S300/2NPT	28	28	28	22

* **Warranty Conditions.** 5 year cylinder and solar panels, 3 year labour on cylinder, 1 year parts including labour. Applies to domestic installations only.

¹ Energy reduction of up to 70% based on Australian Government Approved TRNSYS simulation modelling and apply when replacing an electric water heater with a Rheem solar water heater in zone 3.

² Any financial savings will vary depending upon type of Rheem Solar system installed, orientation and inclination of the solar collectors, type of water heater being replaced, hot water consumption and fuel tariff. Maximum financial savings off your hot water bill are achievable when replacing an electric water heater on continuous tariff.

³ Electric boost models only.

**Eligibility criteria apply.

Materials and specifications are subject to change without notice.

[®] Registered Trademark of Rheem Australia Pty Ltd.

[™] Trademark of Rheem Australia Pty Ltd.



Rheem Australia Pty Ltd.

1 Alan Street, Rydalmere, New South Wales 2116, Australia
PO Box 6, Rydalmere, New South Wales 2116, Australia.

