

Owner's Guide and Installation Instructions

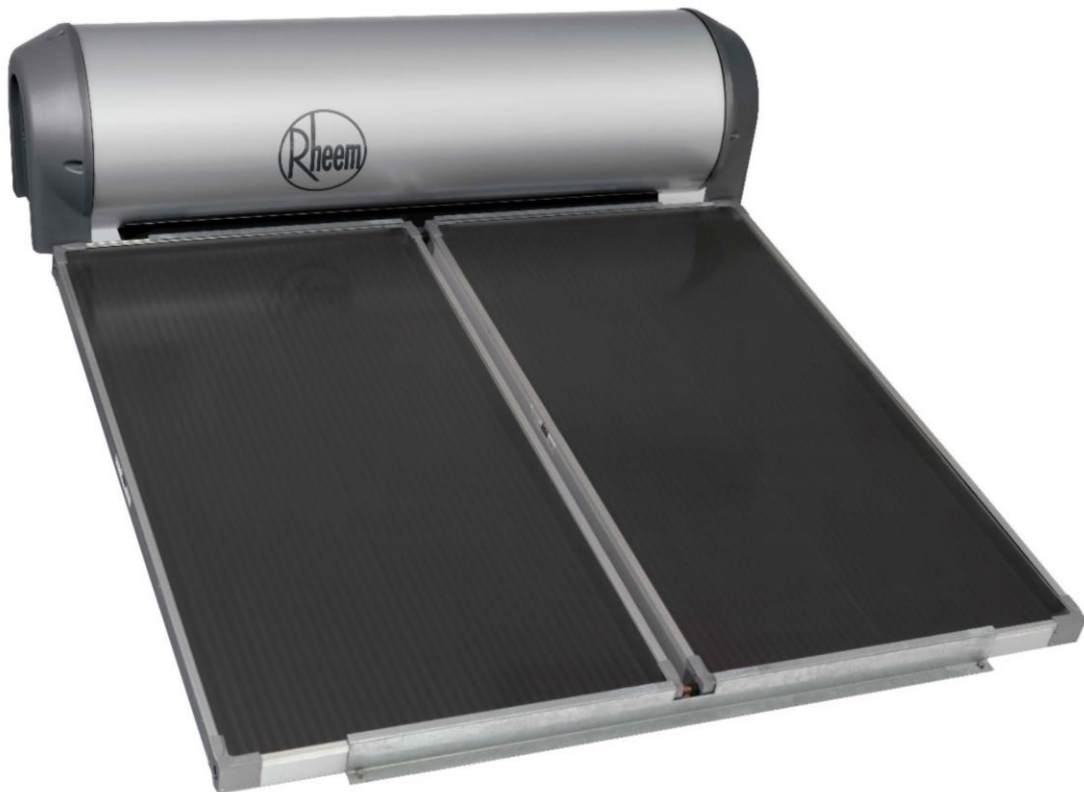

Solar Thermosiphon Water Heater Stainless Steel Tanks



WARNING: Plumber – Be Aware

Use copper pipe ONLY. Plastic pipe MUST NOT be used.

It is a requirement of a solar water heater installation that all pipe work be in copper and not plastic, due to the effects of high water temperatures.

*This water heater must be installed and serviced by a qualified person.
Please leave this guide with the householder or responsible officer.*



WARNING: Plumber – Be Aware

- The solar hot and solar cold pipe work between the thermosiphon solar storage tank and the solar collectors are supplied in the parts kit. The supplied copper solar hot and solar cold pipes **MUST BE** used.
- If the solar water heater is installed either on a metal roof or in a trafficable area, such as on an accessible roof, then the solar hot and solar cold pipes must be insulated. The solar hot and solar cold pipes may be required to be insulated to comply with local regulations.

If insulation is required, the full length of the solar hot and solar cold pipes **MUST BE** insulated.

The insulation must:

- be of a closed cell type or equivalent, suitable for a solar water heating application and capable of withstanding the temperature of the water or closed circuit fluid generated by the solar collectors under stagnation conditions

The specification of the chosen insulation material should be checked with the insulation manufacturer prior to installation as different materials may vary in temperature tolerance.

- be at least 13 mm thick
- be weatherproof and UV resistant
- be fitted up to and cover the connections on both the solar storage tank and the solar collectors.

The insulation will offer protection to a metal roof against corrosion due to water running off the copper pipes, assist in avoiding accidental contact with the solar pipe work as very high temperature water can flow from the solar collectors to the solar storage tank, and also reduce pipe heat losses.

- Plastic pipe **MUST NOT** be used, as it will not withstand the high temperature and pressure of the closed circuit fluid (indirect system) and water (direct system) generated by the solar collectors under stagnation conditions. Failure of plastic pipe can lead to the release of high temperature closed circuit fluid and water and cause severe water damage and flooding.
- There **MUST BE** a continuous fall of a minimum 10° in the pipe work from the thermosiphon solar storage tank to the solar collectors. The highest point of the solar cold pipe and solar hot pipe must be where they connect to the thermosiphon solar storage tank, otherwise thermosiphoning will not occur.
- The solar water heater is to be isolated during the testing and commissioning of the heated water reticulation system in a building, in accordance with Clause 9.3 (a) of AS/NZS 3500.4:2021.

An electronic copy of these Owner's Guide and Installation Instructions can be downloaded from rheem.com.au.

PATENTS

This water heater may be protected by one or more patents or registered designs in the name of Rheem Australia Pty Ltd.

TRADE MARKS

© Registered trademark of Rheem Australia Pty Ltd.
™ Trademark of Rheem Australia Pty Ltd.

Note: Every care has been taken to ensure accuracy in preparation of this publication. No liability can be accepted for any consequences, which may arise as a result of its application.

CONTENTS

HOUSEHOLDER

This booklet contains important information about your new water heater, including terms of the Rheem warranty.

We recommend you read pages 8 to 24,
and the terms of the Rheem warranty on pages 4 to 7.

The other pages are intended for the installer but may be of interest.

Warranty	4
Safety, Warnings, Installation Notes	8
About Your Water Heater	11
Maintenance Requirements.....	17
Water Supplies.....	19
Save A Service Call	22
Installation.....	25
Installation – Solar Collectors	40
System Assembly.....	43
Connections – Plumbing	56
Connections – Electrical.....	60
Multiple Installations	63
Commissioning.....	65
Draining The Closed Circuit Fluid – 52H Series.....	70
Draining and Flushing the Solar Storage Tank	71
Installation Report.....	77

RHEEM AUSTRALIA PTY LTD, A.B.N. 21 098 823 511, www.rheem.com.au
For Service Telephone 131 031 AUSTRALIA

RHEEM SOLAR THERMOSIPHON WATER HEATER WARRANTY – AUSTRALIA ONLY

SOLAR THERMOSIPHON WATER HEATER SYSTEMS – 52L, 52H

1. THE RHEEM WARRANTY – GENERAL

- 1.1 This warranty is given by Rheem Australia Pty Limited ABN 21 098 823 511 of 1 Alan Street, Rydalmere New South Wales.
- 1.2 Rheem offer a trained and qualified national service network who will repair or replace components at the address of the water heater subject to the terms of the Rheem warranty. Rheem Service, in addition can provide preventative maintenance and advice on the operation of your water heater. The Rheem Service contact number is 131031, with Contact Centre personnel available 24 hours, 7 days a week to take your call and if necessary to arrange a service call for during normal working hours Monday to Friday (hours subject to change).
- 1.3 For details about this warranty, you can contact us on 131031 or by email at warrantyenquiry@rheem.com.au (not for service bookings).
- 1.4 The terms of this warranty and what is covered by it are set out in sections 2 and 3 and apply to water heaters manufactured after 1st September 2014.
- 1.5 If a subsequent version of this warranty is published, the terms of that warranty and what is covered by it will apply to water heaters manufactured after the date specified in the subsequent version.

2. TERMS OF THE RHEEM WARRANTY AND EXCLUSIONS TO IT

- 2.1 The decision of whether to repair or replace a faulty component is at Rheem's sole discretion.
- 2.2 If you require a call out and we find that the fault is not covered by the Rheem warranty, you are responsible for our standard call out charge. If you wish to have the relevant component repaired or replaced by Rheem, that service will be at your cost.
- 2.3 Where a failed component or cylinder is replaced under this warranty, the balance of the original warranty period will remain effective. The replacement does not carry a new Rheem warranty.
- 2.4 Where the water heater is installed outside the boundaries of a metropolitan area as defined by Rheem or further than 25 km from either a regional Rheem branch office or an Accredited Rheem Service Agent's office, the cost of transport, insurance and travelling between the nearest branch office or Rheem Accredited Service Agent's office and the installed site shall be the owner's responsibility.
- 2.5 Where the water heater is installed in a position that does not allow safe or ready access, the cost of that access, including the cost of additional materials handling and/or safety equipment, shall be the owner's responsibility. In other words, the cost of dismantling or removing cupboards, doors or walls and the cost of any special equipment to bring the water heater to floor or ground level or to a serviceable position is not covered by this warranty.
- 2.6 This warranty only applies to the original and genuine Rheem water heater in its original installed location and any genuine Rheem replacement parts.
- 2.7 The Rheem warranty does not cover faults that are a result of:
 - a) Accidental damage to the water heater or any component (for example: (i) Acts of God such as floods, storms, fires, lightning strikes and the like; and (ii) third party acts or omissions).
 - b) Misuse or abnormal use of the water heater.
 - c) Installation not in accordance with the Owner's Guide and Installation Instructions or with relevant statutory and local requirements in the State or Territory in which the water heater is installed.
 - d) Connection at any time to a water supply that does not comply with the water supply guidelines as outlined in the Owner's Guide and Installation Instructions.

RHEEM SOLAR THERMOSIPHON WATER HEATER WARRANTY – AUSTRALIA ONLY

SOLAR THERMOSIPHON WATER HEATER SYSTEMS – 52L, 52H

- e) Repairs, attempts to repair or modifications to the water heater by a person other than Rheem Service or a Rheem Accredited Service Agent.
 - f) Faulty plumbing or faulty power supply.
 - g) Failure to maintain the water heater in accordance with the Owner's Guide and Installation Instructions.
 - h) Transport damage.
 - i) Fair wear and tear from adverse conditions (for example, corrosion).
 - j) Cosmetic defects.
 - k) Breakage of collector glass for any reason including hail damage (we suggest that the collector glass be covered by your home insurance policy).
 - l) Ice formation in the waterways of a: direct open circuit thermosiphon system; or an indirect closed circuit thermosiphon system due to non Rheem approved or incorrectly mixed closed circuit fluid being used.
 - m) Non Rheem approved or incorrectly mixed closed circuit fluid being used or incorrect or insufficient filling of the closed circuit system with the closed circuit fluid.
- 2.8 Subject to any statutory provisions to the contrary, this warranty excludes any and all claims for damage to furniture, carpet, walls, foundations or any other consequential loss either directly or indirectly due to leakage from the water heater, or due to leakage from fittings and/ or pipe work of metal, plastic or other materials caused by water temperature, workmanship or other modes of failure.
- 2.9 If the water heater is not sized to supply the hot water demand in accordance with the guidelines in the Rheem water heater literature, any resultant fault will not be covered by the Rheem warranty.

3. WHAT IS COVERED BY THE RHEEM WARRANTY FOR THE WATER HEATERS DETAILED IN THIS DOCUMENT

- 3.1 Rheem will repair or replace a faulty component of your water heater if it fails to operate in accordance with its specifications as follows:

RHEEM SOLAR THERMOSIPHON WATER HEATER WARRANTY – AUSTRALIA ONLY

SOLAR THERMOSIPHON WATER HEATER SYSTEMS – 52L, 52H

What components are covered	The period from the date of installation in which the fault must appear in order to be covered	What coverage you receive
-----------------------------	--	---------------------------

All Systems (all installations)

All components	Year 1	Repair and/or replacement of the faulty component, free of charge, including labour.
----------------	--------	--

52H/SP Series Systems

The cylinder (if the water heater is installed in a single-family domestic dwelling)	Years 2 to 7	Replacement cylinder, free of charge. Installation and repair labour costs are the responsibility of the owner.
The cylinder (if the water heater is <u>not</u> installed in a single-family domestic dwelling)	Years 2 & 3	Replacement cylinder, free of charge. Installation and repair labour costs are the responsibility of the owner.
The solar collector (all installations)	Years 2 to 5	Replacement solar collector, free of charge. Installation and repair labour costs are the responsibility of the owner.

52L/NPT, 52H/NPT Series Systems

(if the water heater is installed in a single-family domestic dwelling)

The cylinder and solar collector(s)	Years 2 & 3	Replacement cylinder or solar collector, free of charge, including labour.
	Years 4 to 7	Replacement cylinder or solar collector, free of charge. Installation and repair labour costs are the responsibility of the owner.

52L, 52H / L & CS07 Series Systems

(if the water heater is installed in a single-family domestic dwelling)

All components	Year 2 to 5	Repair and/or replacement of the faulty component, free of charge, including labour.
The cylinder and solar collector(s)	Years 6 to 10	Replacement cylinder or solar collector, free of charge. Installation and repair labour costs are the responsibility of the owner.

52L, 52H / NPT, L & CS07 Series Systems

(if the water heater is not installed in a single-family domestic dwelling)

The cylinder and solar collector(s)	Years 2 & 3	Replacement cylinder or solar collector, free of charge. Installation and repair labour costs are the responsibility of the owner.
	Year 4	Replacement cylinder or solar collector, supplied at 75% of list price. Installation and repair labour costs and 25% of cylinder or solar collector list price are the responsibility of the owner.
	Year 5	Replacement cylinder or solar collector, supplied at 50% of list price. Installation and repair labour costs and 50% of cylinder or solar collector list price are the responsibility of the owner.

RHEEM SOLAR THERMOSIPHON WATER HEATER WARRANTY – AUSTRALIA ONLY

SOLAR THERMOSIPHON WATER HEATER SYSTEMS – 52L, 52H

- 3.2 Without limiting the periods shown in the table in Clause 3.1 for a 52H/SP series system, a 5-year whole-of-product warranty applies where a rebate has been received under Solar Victoria's Solar Homes Program for a water heater installed from the 1st July 2023. For further details, call 131 031. Proof of receipt of the rebate is required to be produced at the time of the service call.

4. ENTITLEMENT TO MAKE A CLAIM UNDER THIS WARRANTY

- 4.1 To be entitled to make a claim under this warranty you need to:
- a) Be the owner of the water heater or have consent of the owner to act on their behalf.
 - b) Contact Rheem Service without undue delay after detection of the defect and, in any event, within the applicable warranty period.
- 4.2 You are not entitled to make a claim under this warranty if your water heater:
- a) Does not have its original serial numbers or rating labels.
 - b) Is not installed in Australia.

5. HOW TO MAKE A CLAIM UNDER THIS WARRANTY

- 5.1 If you wish to make a claim under this warranty, you need to:
- a) Contact Rheem on 131031 and provide owner's details, address of the water heater, a contact number and date of installation of the water heater or if that's unavailable, the date of manufacture and serial number (from the rating label on the water heater).
 - b) Rheem will arrange for the water heater to be tested and assessed on-site.
 - c) If Rheem determines that you have a valid warranty claim, Rheem will repair or replace the water heater in accordance with this warranty.
- 5.2 Any expenses incurred in the making of a claim under this warranty will be borne by you.

6. THE AUSTRALIAN CONSUMER LAW

- 6.1 Our goods come with guarantees that cannot be excluded under the Australian Consumer Law. You are entitled to a replacement or refund for a major failure and for compensation for any other reasonably foreseeable loss or damage. You are also entitled to have the goods repaired or replaced if the goods fail to be of acceptable quality and the failure does not amount to a major failure.
- 6.2 The Rheem warranty (set out above) is in addition to any rights and remedies that you may have under the Australian Consumer Law.

SAFETY, WARNINGS, INSTALLATION NOTES

It is important you read the following [Safety and Warnings](#), and [Relief Valves](#) information.

If the solar water heater is installed with an in-series booster water heater, it is also important you read the Safety and Warnings, and Relief Valves information relating to the function and operation of the in-series water heater. Refer to the Owner's Guide and Installation Instructions supplied with the in-series water heater.

SAFETY AND WARNINGS

- The water heater under normal use and summer solar conditions should heat the water in the solar storage tank to 60°C to 75°C. This water temperature can be exceeded and reach up to around 90°C during periods of high solar radiation conditions and reduced hot water usage.

During times of low solar energy gain or if boosting of the water temperature is required, an electric heating unit will heat the water temperature to 60°C or up to 70°C depending upon the thermostat setting. If this water heater is installed with an in-series booster water heater, then this temperature can be 70°C or higher if the booster water heater is a continuous flow gas booster or 60°C or higher if the booster water heater is a storage water heater.

These temperatures are sufficiently hot to cause severe scalding. Water at this temperature may have been plumbed to fixtures where water hotter than 50°C is allowed, such as the kitchen and laundry.

Refer to:

- [“How Hot Should the Water Be?”](#) on page 12, and
 - [“Hotter Water Increases the Risk of Scald Injury”](#) on page 12, and
 - [“Temperature Adjustment”](#) on page 13.
- This water heater is only intended to be operated by persons who have the experience or the knowledge and the capabilities to do so.
 - This water heater is not intended to be operated by persons with reduced physical, sensory or mental capabilities i.e. the infirm, or by children. Children should be supervised to ensure they do not interfere with or play with or at the water heater.
 - Do not touch any exposed pipe work or fittings connecting the solar storage tank and the solar collectors, as this may result in a burn injury. Very high temperature closed circuit fluid or hot water and in some circumstances high temperature steam can be generated by the solar collectors under certain conditions and this flows through the pipe work from the solar collectors to the solar storage tank.

Note: Any exposed pipe work or fittings in the collector circuit where the installation is in a trafficable area, such as on an accessible roof, should be attended to and covered with insulation. Phone Rheem Service or their nearest Accredited Service Agent to arrange for an inspection.

- If the electrical conduit to the solar storage tank is damaged, it must be replaced by a qualified person in order to avoid a hazard. Phone Rheem Service or their nearest Accredited Service Agent to arrange for an inspection.
- This water heater uses 220 V - 240 V a.c. electrical power for operation of the control systems and the electrically operated components. The removal of the side cover will expose 220 V - 240 V a.c. wiring. It must only be removed by a qualified person. Do not operate the water heater with the cover removed.
- This water heater is supplied with a thermostat, over-temperature cut-out, a combination temperature pressure relief valve and a 52H series model also has a closed circuit pressure relief valve. These devices must not be tampered with or removed. The water heater must not be operated unless each of these devices is fitted and is in working order.

The Rheem warranty may not cover faults if relief valves or other safety devices are tampered with or if the installation is not in accordance with these instructions.

- **DANGER:** The operation of the over-temperature cut-out on a thermostat indicates a possibly dangerous situation. If the over-temperature cut-out operates, it must not be reset and the water heater must be serviced by a qualified person.
- For continued safety of this water heater, it must be installed, operated, and maintained in accordance with the Owner's Guide and Installation Instructions.

- Do not remove the closed circuit relief valve (52H series model) as there may be a very high scalding risk present. When operating in daylight, the heat exchange circuit will be pressurised and can contain superheated fluid and may contain steam. At other times, the circuit may be pressurised and contain high temperature fluid.
- Should the water from a 52H series water heater appear blue or if blue closed circuit fluid is noticed around the base of the water heater or solar collectors, this indicates a leak of the closed circuit fluid from the heat exchanger or the solar collectors. The closed circuit fluid is non-toxic and not hazardous to health. Phone Rheem Service or their nearest Accredited Service Agent to arrange for an inspection.
- The 52H closed circuit system has freeze protection. The amount of closed circuit concentrate supplied with this water heater provides protection in frost prone areas to a certain temperature. The [table on page 66](#) lists the percentage of Coolblend concentrate fluid in the closed circuit of each system and the recommended minimum ambient temperature for the system, for the number of bottles supplied with each system.

Refer to [“Freeze Protection”](#) on page 13.

- The 52L open circuit system does not have freeze protection. The system is not suitable for installation in areas subject to frost or freeze conditions.
- The lever on the temperature pressure relief valve and expansion control valve requires to be operated every six (6) months to clear any deposits and to ensure the valve and its drain line are not blocked.

Refer to:

- [“Relief Valves”](#) on page 9, and
- [“Minor Maintenance Every Six Months”](#) on page 17.
- Servicing of a water heater must only be carried out by qualified personnel. Phone Rheem Service or their nearest Accredited Service Agent.
- Only a person qualified to install or service a water heater can drain the water heater if this is required.
- Do not modify this water heater.

RELIEF VALVES

Temperature Pressure Relief Valve

This water heater incorporates a temperature pressure relief valve located near the top of the solar storage tank. This valve is essential for the water heater's safe operation.

It is possible for the valve to discharge a quantity of water through the drain line during each heating period. This quantity should be equal to approximately 1/50 of the hot water used, as water expands by this volume when heated.

Expansion Control Valve

In many areas, including South Australia and scaling water areas, it is mandatory an expansion control valve is fitted to the cold water line to the water heater.

The expansion control valve will discharge the quantity of water from its drain line during the heating period instead of the temperature pressure relief valve as it has a lower pressure rating.

Valve Operation

Continuous leakage of water from either valve and its drain line may indicate a problem with the water heater. Refer to [“Temperature Pressure Relief Valve or Expansion Control Valve Running”](#) on page 23.

⚠ Warning: Never block the outlet of either valve or their drain lines for any reason. A relief valve drain must be left open to atmosphere, and be installed in a continuously downward direction.

In locations where water pipes are prone to freezing, the relief valve drain line must be insulated and not exceed 300 mm in length before discharging into a tundish through an air gap.

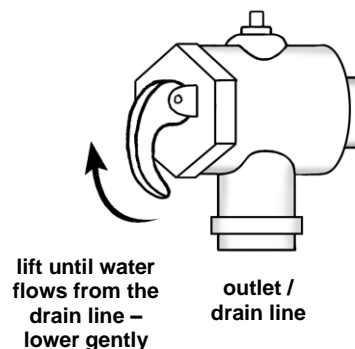
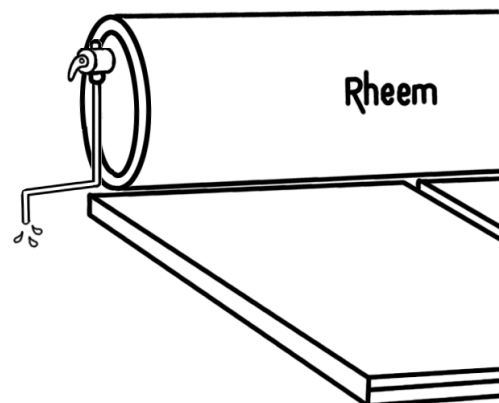

The easing lever on the temperature pressure relief valve and expansion control valve should be operated once every six (6) months to clear any deposits and ensure the valve and its drain line are not blocked. **It is very important the lever is raised and lowered gently.** Refer to “[Minor Maintenance Every Six Months](#)” on page 17.

If the relief valve easing lever is not readily and safely accessible, contact Rheem Service or their nearest Accredited Service Agent. Do not attempt to climb onto a non-trafficable roof to operate the relief valve lever.

⚠ Warning: Water discharged from the temperature pressure relief valve drain line will be hot. Exercise care to avoid any splashing of water by standing clear of the drain line’s point of discharge when operating either valve’s easing lever.

⚠ DANGER: Failure to operate the easing lever on the relief valve once every six (6) months may result in the solar storage tank cylinder failing, or under certain circumstances, exploding.

If water does not flow freely from the drain line when the lever is lifted, then the water heater must be checked. Phone Rheem Service or their nearest Accredited Service Agent to arrange for an inspection.

The temperature pressure relief valve should be replaced at intervals not exceeding five (5) years and the expansion control valve should be checked for performance or replaced at intervals not exceeding five (5) years. The checking of the valves performance or replacement should occur more frequently in areas where there is a high incidence of water deposits. Refer to “[Water Supplies](#)” on page 19.

INSTALLATION NOTES

This water heater must be installed:

- by a qualified person,
- in accordance with the installation instructions,
- in compliance with the Plumbing Code of Australia (PCA) and Plumbing Standard AS/NZS 3500.4,
 - This water heater is designed for outdoor installation.
 - This water heater is intended to be permanently connected to the water mains and not connected by a hose-set. A braided flexible hose or semi-flexible connector may be used for connection to the water heater, where permitted by AS/NZS 3500.4.
- in compliance with the Australian / New Zealand Wiring Rules AS/NZS 3000,
 - An isolation switch must be installed at the switchboard in the electrical circuit to the water heater in accordance with the Wiring Rules, so the water heater can be switched off. Refer to “[Connections – Electrical](#)” on page 60.
 - The power supply wires are to be directly connected to the terminal block and earth tab connection, with no excess wire loops inside the front cover. The temperature rating of the power supply wires insulation must suit this application, or the wiring protected by insulating sleeving with an appropriate temperature rating if it can make contact with the internal storage cylinder. The temperature of the internal storage cylinder can reach 95°C during its operation.
- in compliance with all local codes and regulatory authority requirements.

Installation and commissioning requirements and details for the installing plumber and licensed electrical worker are contained on [pages 25 to 69](#).

Mains pressure water supply

The water heater is designed to operate at mains pressure by connecting directly to the mains water supply.

The water heater is supplied with a temperature pressure relief valve with a pressure rating of 850 kPa and an expansion control valve with a pressure rating of 700 kPa.

The maximum mains water supply pressure for the water heater is 680 kPa when an expansion control valve is installed. If the mains supply pressure in your area exceeds this value, a pressure limiting valve must be installed.

The supply pressure should be greater than 350 kPa for true mains pressure operation to be achieved.

ABOUT YOUR WATER HEATER

WATER HEATER APPLICATION

This water heater is designed for use in a single family domestic dwelling for the purpose of heating potable water. Its use in an application other than this may shorten its life.

MODEL TYPE

Your Rheem® thermosiphon solar water heater is designed for both the solar collectors and the solar storage tank to be roof mounted. The solar storage tank has a Colorbond® jacket. The 52L tank (direct system) is suitable for installation with NPT200, L or CSA2007 solar collectors and the 52H tank (indirect system) is suitable for installation with SPA2000, NPT200, L or CSA2007 solar collectors.

The 52L series systems do not have freeze protection. These systems are not suitable for installation in areas subject to frost or freeze conditions. Freeze conditions occur below 6°C. These systems have NO WARRANTY for freeze damage (refer to “[Terms of the Rheem Warranty](#)” on page 4).

The 52H series systems are suitable for installation in areas subject to frost or freeze conditions. Freeze conditions occur below 6°C. These systems have NO WARRANTY for freeze damage if non Rheem approved closed circuit fluid has been used or if the closed circuit fluid has been incorrectly mixed (refer to “[Terms of the Rheem Warranty](#)” on page 4).

This water heater is designed to be installed as an electric boosted solar water heater with its booster heating unit connected to a power supply, however it may be installed with an in-series continuous flow or storage booster.

If this water heater is installed with an in-series booster, then the electric booster heating unit will not be connected to a power supply and the references to the electric booster heating unit, thermostat and boosting controls in this Guide will not be applicable to the installation. For information relating to the function and operation of the in-series booster, refer to the Owners Guide and Installation Instructions supplied with the booster water heater.

SOLAR OPERATION

The Rheem solar thermosiphon system has its stainless steel solar storage tank installed on the roof directly coupled to the solar collectors. The 52L series are direct solar hot water systems and the 52H series are indirect solar hot water systems with a heat exchanger in the solar storage tank.

The solar water heater uses the thermosiphon principle, without the need for a pump, circulator or sensors. It works on the simple scientific fact that hot fluid rises. The solar collector's low-iron content solar glass allows more solar energy from the sun to pass through and be used to heat the collector's absorber plate than conventional glass. As the sun heats the water or closed circuit fluid in the solar collectors, the increase in temperature causes the fluid to rise through a copper pipe into the storage tank (52L series) or heat exchanger (52H series) where it transfers its heat into the water in the solar storage tank. This allows cooler fluid from the storage tank or heat exchanger to flow into the solar collectors to be heated by the sun's energy. This process continues while solar energy is available.

52L series: The solar storage tank and solar collectors are connected by copper pipe work and form an open circuit which is filled with potable water.

52H series: The heat exchanger and solar collectors are connected by copper pipe work and form a closed circuit which is filled with closed circuit fluid. The closed circuit fluid is a solution of a blue, non-toxic food grade propylene glycol concentrate mixed with water. The closed circuit concentrate is used to lower the freezing temperature of the closed circuit fluid and provides protection against freezing. The closed circuit also provides protection to the solar collectors and solar pipe work against harsh water chemistry.

Automatic safety controls are fitted to the water heater to provide safe and efficient operation.



ELECTRIC BOOSTING

Water stored in the solar storage tank can be heated by an electric booster heating unit. The booster heating unit is for heating the water at times of low solar energy gain, such as during very cloudy or rainy weather, or during the colder months.

The amount of water heated by the raised booster heating unit of the thermosiphon solar storage tank is 90 litres (180 tank) or 150 litres (300 tank).

The thermosiphon solar water heater is most suited for the booster heating unit to be connected to either a continuous, or a time of use, or an extended Off-Peak (overnight and day) electricity supply. A timer can also be used to control the boosting periods and help maximise solar savings. Refer to “Booster Control” on page 14.

The booster heating unit may be connected to an Off-Peak (overnight) electricity supply, however this will only allow the booster to heat the water overnight. If this type of connection is considered, care must be taken to ensure there is sufficient boost capacity to meet the household’s full day and night’s hot water supply during periods of no or low solar gain, particularly in cold weather. There is also an increased risk of temperature run down occurring, particularly in cooler weather (refer to “Temperature Redistribution” on page 23).

The booster heating unit is controlled by an electric thermostat. The thermostat and its over temperature energy cut out are mounted on the solar storage tank behind the front cover. The water temperature is automatically controlled to the thermostat setting when the booster heating unit is energised.

HOW HOT SHOULD THE WATER BE?

The temperature the system will operate at under solar radiation will depend upon the level of solar radiation available, orientation and inclination of the solar collectors, incoming cold water temperature and volume of hot water used.

Under normal household use and average operating conditions, the system may achieve a water temperature of approximately twice the maximum daily outside air temperature. In summer solar conditions this can be up to 60°C to 75°C. This water temperature can be exceeded and reach up to around 90°C during periods of high solar radiation conditions and reduced hot water usage.

During periods of low solar energy gain, the water temperature can be boosted by the thermostatically controlled electric booster heating unit. Refer to “Booster Control” on page 14. Rheem recommends the thermostat is set at 60°C to maximise solar contribution.

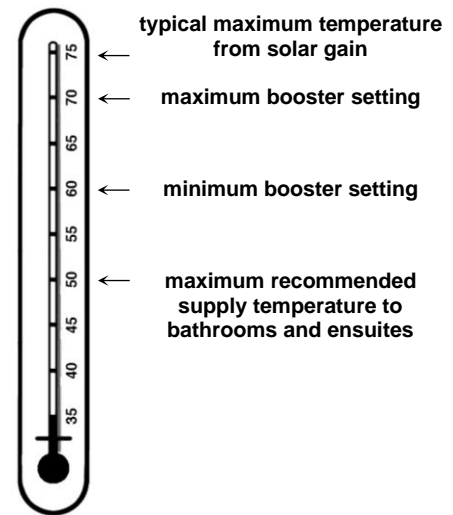

Note: AS 3498 requires that a water heater provides the means to inhibit the growth of Legionella bacteria in potable water. This water heater can satisfy this AS 3498 requirement provided the electric booster is energised for a sufficient period each day and the electric booster thermostat setting is 60°C or higher.

If this water heater is installed with an in-series continuous flow gas booster, then this requirement of AS 3498 can be satisfied provided the booster is energised, its preset outlet temperature setting is 70°C or higher and a remote temperature controller is not used.

If this water heater is installed with an in-series storage booster, then this requirement of AS 3498 can be satisfied provided the storage booster is energised and its thermostat setting is 60°C or higher.

HOTTER WATER INCREASES THE RISK OF SCALD INJURY

⚠ Warning: The water heater can deliver hot water under normal use and summer solar conditions at a temperature of 60°C to 75°C. This water temperature can be exceeded and reach up to around 90°C during periods of high solar radiation conditions and reduced hot water usage. These temperatures are sufficiently hot to cause severe scalding. Water at this temperature may have been plumbed to fixtures where water hotter than 50°C is allowed, such as the kitchen and laundry.

Check the water temperature before use, such as when entering a shower or filling a bath or basin, to ensure it is suitable for the application and will not cause scald injury.

We recommend and it may also be required by regulations that an approved temperature limiting device be fitted into the hot water pipe work to the bathroom and ensuite when this water heater is installed. This will keep the water temperature below 50°C at the bathroom and ensuite. The risk of scald injury will be reduced and still allow hotter water to the kitchen and laundry.

TEMPERATURE ADJUSTMENT

The water heater features a tradesperson adjustable thermostat. This requires a licensed electrical worker to make any temperature adjustments. The thermostat has a maximum temperature setting of 70°C and a minimum temperature setting of 60°C.

We advise you to have a licensed electrical worker adjust the thermostat to the lowest setting which meets your needs, especially if there are young children or elderly people in the home. Refer to [“Hotter Water Increases the Risk of Scald Injury”](#) on page 12.

PRECAUTIONS

The water heater must be maintained in accordance with the Owner's Guide and Installation Instructions. Refer to [“Maintenance Requirements”](#) on page 17.

If this water heater is to be used where an uninterrupted hot water supply is necessary for your application or business you should ensure that you have back up redundancy within the hot water system design. This should ensure the continuity of hot water supply in the event that this water heater were to become inoperable for any reason. We recommend you seek advice from your plumber or specifier about your needs and building back up redundancy into your hot water supply system.

FREEZE PROTECTION

The 52H series solar water heaters are an indirect closed circuit solar hot water system with a heat exchanger in the solar storage tank. The heat exchanger and solar collectors form a closed circuit and are filled with closed circuit fluid. The closed circuit fluid is a solution of a blue, non-toxic food grade propylene glycol concentrate mixed with water. The closed circuit concentrate is used to lower the freezing temperature of the closed circuit fluid and provides protection against freezing.

During installation, the closed circuit concentrate is blended with water. The amount of closed circuit concentrate supplied with this water heater provides protection in frost prone areas to a certain temperature. The [table on page 66](#) lists the percentage of Coolblend concentrate fluid in the closed circuit of each system and the recommended minimum ambient temperature for the system, for the number of bottles supplied with each system. If a lower temperature protection is anticipated, additional Coolblend concentrate will be required to provide a greater concentration in the closed circuit fluid.

The system has NO WARRANTY for freeze damage if non Rheem approved closed circuit fluid has been used or if the closed circuit fluid has been incorrectly mixed (refer to [“Terms of the Rheem Warranty”](#) on page 4).

Note: The 52L series systems do not have freeze protection. The system is not suitable for installation in areas subject to frost or freeze conditions. Freeze conditions occur below 6°C. The system has NO WARRANTY for freeze damage (refer to [“Terms of the Rheem Warranty”](#) on page 4).

CLOSED CIRCUIT JACKET RELIEF VALVE

The tank's closed circuit heat exchange jacket has a relief valve located in the vent pipe of the jacket. This relief valve is to prevent over-pressurisation of the closed circuit either due to incorrect filling or abnormal operating conditions.

During the water heater's first few months of operation, a small amount of fluid may discharge from the relief valve until the ideal closed circuit fluid volume is established. Discharges from the valve after this time could indicate the water heater is not operating efficiently. Under these circumstances phone Rheem Service or their nearest Accredited Service Agent to arrange for an inspection. Do not attempt to service the water heater yourself.

Do not remove the closed circuit relief valve as there may be a very high scalding risk present. When operating in daylight, the heat exchange circuit will be pressurised and can contain superheated fluid and may contain steam. At other times, it may be pressurised and contain high temperature fluid.

BOOSTER CONTROL

An isolating switch is installed in the electrical meter box for an electrically in-tank boosted solar storage tank. This should be left switched on to allow the booster heating unit to operate if required. The booster heating unit is for heating the water at times of low solar energy gain, such as during very cloudy or rainy weather, or during the colder months. The booster heating unit will only activate if heating is required and power is available from the switchboard. When the water is below the thermostat setting, the booster heating unit will turn on and heat the water. The booster heating unit will automatically turn off when the temperature of the water reaches the thermostat setting.

Leaving the isolating switch switched on will also provide a sufficient period of time each day for the booster heating unit to operate, if required, to satisfy the requirements of AS 3498.

The amount of water heated by the raised booster heating unit of the solar storage tank will be 150 litres (300 litre model), or 90 litres (180 litre model).

Timer Control Switch

A suitably rated timer control switch can be installed and will help maximise energy savings with an electrically boosted solar water heater connected to a **continuous, time of use or extended Off-Peak (overnight and day)** electricity supply. Further information for a licenced electrical worker on the recommended methods of wiring the timer are outlined in **“Booster Control”** on page 61.

Programming the Timer

Power must be available to the timer control switch before the booster heating unit can be activated. The timer should be programmed:

- to suit the hot water consumption pattern of the household,
- with the end of the period to coincide with the commencement of the evening hot water usage,
A second period, such as prior to the morning hot water usage, may be necessary.
- to enable a boosting period of not less than the recommended continuous length of time for boosting, and
- for a period when power will be available to the timer.

Note: When daylight saving time applies, you may consider resetting the timer accordingly.

The recommended continuous length of time for boosting is:

Model	Minimum winter cold water temperature		Temperature rise	Booster heating unit size		
				2.4 kW	3.6 kW	4.8 kW
180	Cool / temperate climate	10°C	50°C	2 ¼ hours	1 ½ hours	1 ¼ hours
	Temperate / sub-tropical climate	15°C	45°C	2 hours	1 ½ hours	1 hour
	Tropical climate	20°C	40°C	1 ¾ hours	1 ¼ hours	1 hour
300	Cool / temperate climate	10°C	50°C	3 ¾ hours	2 ½ hours	2 hours
	Temperate / sub-tropical climate	15°C	45°C	3 ½ hours	2 ¼ hours	1 ¾ hours
	Tropical climate	20°C	40°C	3 hours	2 hours	1 ½ hours

The recommended boosting periods are sufficient to allow the booster heating unit to heat up the boost volume of the solar storage tank to 60°C where the winter cold water temperatures do not fall below those shown. This may be necessary during periods of very low solar energy gain through the solar collectors, such as during constant rain or extremely cloudy weather, particularly in winter when the incoming cold water temperature is lower. The period will also provide a sufficient heat up time for the electric booster to operate, if required, to satisfy the requirements of AS 3498.

The booster heating unit will only activate if heating is required and power is available from the timer. When the water is below the thermostat setting, the booster heating unit will turn on and heat the water. The booster heating unit will automatically turn off either when the temperature of the water reaches the thermostat setting or at the end of the timer period, whichever comes first.

RAINWATER COLLECTION SYSTEM

If the 52H series solar water heater is installed on a section of roof which is part of a rainwater collection system, then it is recommended this section of roof and its gutter be isolated from the rainwater collection system.

The closed circuit fluid acts as an anti-freeze agent and rust inhibitor, is non-toxic to humans and is harmless to the environment. However it does have an adverse effect on water stored in rainwater tanks. It will kill microscopic algae typically present in rainwater tanks and cause an unpleasant odour to develop. This will result in the rainwater tank having to be drained and cleaned.

If a rainwater tank does become contaminated with closed circuit fluid, then the following actions should be undertaken by a qualified person. Additional actions may be necessary to return the water supply to a consumable state.

- Correct the leak or spillage.
- Wash down the roof area where the spill or leak has occurred.
- Flush out the gutters and down pipes.
- Determine how the closed circuit fluid made its way into the rainwater tank. If the section of roof supporting the solar water heater is not isolated from the rainwater collection system, then this should be remedied.
- Empty the rainwater tank and clean out all algae from the inside of the tank.
- Refill the rainwater tank with fresh water.

Refer to ["Rainwater Collection System"](#) on page 28 for additional information.

TO TURN OFF THE WATER HEATER

If you plan to be away from home for a few nights, we suggest you leave the water heater switched on.

If it is necessary to turn off the water heater:

- Switch off the electrical supply to the solar storage tank at the hot water isolating switch on the switch board.
- Close the cold water isolation valve at the inlet to the water heater.

TO TURN ON THE WATER HEATER

- Open the cold water isolation valve fully at the inlet to the water heater.
- Switch on the electrical supply to the solar storage tank at the hot water isolating switch on the switch board.
- Check and if required reset the timer, if one is installed.

GOING ON HOLIDAYS

If you plan to be away from home, conserve energy by switching the booster switch "OFF". Refer to ["To Turn Off the Water Heater"](#) on page 15. Also if the system is not used for a period in excess of 2 weeks it is recommended the solar collectors be covered.

Care should be taken when returning from holidays and the collectors have not been covered. The water in the storage tank can be very hot.

VICTORIAN CUSTOMERS

Notice to Victorian Customers from the Victorian Building Authority. This water heater must be installed by a licensed person as required by the Victorian Building Act 1993.

Only a licensed person will give you a Compliance Certificate, showing that the work complies with all the relevant Standards. Only a licensed person will have insurance protecting their workmanship for 6 years. Make sure you use a licensed person to install this water heater and ask for your Compliance Certificate.

DOES THE WATER CHEMISTRY AFFECT THE WATER HEATER?

The water heater is suitable for most public water supplies, however some water chemistries may have detrimental effects on the water heater, its components and fittings. Refer to [“Water Supplies”](#) on page 19.

If you are in a known harsh water area or you are not sure of your water chemistry, have your water checked against the conditions [described on pages 19 to 21](#).

HOW LONG WILL THE WATER HEATER LAST?

The water heater is supported by a manufacturer’s warranty ([refer to page 4](#)). There are a number of factors that will affect the length of service the water heater will provide. These include but are not limited to the water chemistry, the water pressure, the water temperature (inlet and outlet) and the water usage pattern. Refer to [“Precautions”](#) on page 13.

MAINTENANCE REQUIREMENTS

MINOR MAINTENANCE EVERY SIX MONTHS

It is recommended minor maintenance be performed every six (6) months. Minor maintenance can be performed by the dwelling occupant.

The minor maintenance includes:

- If readily and safely accessible, operate the easing lever on the temperature pressure relief valve. **It is very important the lever is raised and lowered gently.** Refer to “Relief Valves” on page 9.

If the relief valve lever is not readily and safely accessible, contact Rheem Service or their nearest Accredited Service Agent. Do not attempt to climb onto a non-trafficable roof to operate the relief valve lever.

⚠ Warning: Water discharged from the temperature pressure relief valve drain line will be hot. Exercise care to avoid any splashing of water by standing clear of the drain line's point of discharge when operating the valve's easing lever.

- If readily and safely accessible, operate the easing lever on the expansion control valve. **It is very important the lever is raised and lowered gently.** Refer to “Relief Valves” on page 9.

If the relief valve lever is not readily and safely accessible, contact Rheem Service or their nearest Accredited Service Agent. Do not attempt to climb onto a non-trafficable roof to operate the relief valve lever.

MAJOR SERVICE EVERY FIVE YEARS

It is recommended a major service be conducted on the water heater every five (5) years.

⚠ Warning: Servicing of a water heater must only be carried out by a qualified person. Phone Rheem Service or their nearest Accredited Service Agent.

Note: The major service and routine replacement of any components, such as the relief valves, are not included in the Rheem warranty. A charge will be made for this work. Only genuine replacement parts should be used on this water heater.

The major service includes the following actions:

- Replace the temperature pressure relief valve.
- Inspect and flush the expansion control valve. If required, replace the valve.
- Check the booster heating unit for excessive calcium build up or corrosion and replace if necessary.
- Drain, check and refill or replace (if required) the closed circuit fluid (52H series).
- Flush and bleed the solar collectors (52L series).
- Drain and flush the solar storage tank of sediment build-up if required.
- Clean the collector glass.
- Visually check the unit for any potential problems, e.g. broken glass, excessive dust and dirt build-up, shading.
- Check the condition of the pipe insulation, if fitted, on the solar hot and solar cold pipes. Replace or make good if required.
- Inspect all connections.

Note: The solar storage tank may need to be drained during this service. After the completion of the service, the solar storage tank will take some time to reheat the water by solar gain. Depending upon the power supply connection to the booster heating unit, hot water may not be available until the next day.

If a temperature limiting device, water filter or a water softener are installed, their operation should be checked at this time. These checks are not covered within the major service. Components, devices and valves which are not part of the water heater, such as a temperature limiting device, pipe insulation, water filter and water softener are not covered by the Solahart warranty.

COLLECTOR GLASS

Ensure the glass on your solar collectors is free of dust, salt spray or any other matter which may reduce the effectiveness of the solar collectors. Rainfall should keep the collector adequately clean. It is recommended the collector glass be washed clean at least every three months should adequate rain not have fallen in this period.

Collector glass can be hosed down or if the solar collectors are accessible such as on a trafficable roof, wash the collector glass with water and a soft brush when the solar collectors are cool, such as early in the morning. In extremely dusty areas, such as mining towns and locations adjacent to dust forming plants, extra attention may need to be given to keeping the collector glass clean.

Have any trees trimmed which may shade the solar collectors.

Rheem solar collectors have passed the AS/NZS 2712 requirements for resistance to hailstone damage, so it is not normally necessary to fit a guard to a collector. Stone Guards are available to provide a level of protection to the collectors against vandalism or accidental damage. Contact Rheem or your local Rheem Solar Water Heater Distributor for details.

WATER SUPPLIES

This water heater must be installed in accordance with this advice to be covered by the Rheem warranty.

This water heater is manufactured to suit the water conditions of most public reticulated water supplies. However, there are some known water chemistries which can have detrimental effects on the water heater and its operation and/or life expectancy. If you are unsure of your water chemistry, you may be able to obtain information from your local water supply authority. This water heater should only be connected to a water supply which complies with these guidelines for the Rheem warranty to apply.

CHANGE OF WATER SUPPLY

The changing or alternating from one water supply to another can have a detrimental effect on the operation and / or life expectation of a water heater cylinder, a heat exchanger in an indirect solar water heater system, a temperature pressure relief valve, a heating unit and a solar collector in a direct solar water heater system.

Where there is a changeover from one water supply to another, e.g. a rainwater tank supply, bore water supply, desalinated water supply, public reticulated water supply or water brought in from another supply, then water chemistry information should be sought from the supplier or it should be tested to ensure the water supply meets the requirements given in these guidelines for the Rheem warranty to apply.

CHLORIDE AND PH

In a high chloride water supply, the water can corrode stainless steel parts and cause them to fail.

Where the chloride level exceeds 250 mg/L the Rheem warranty does not apply to a stainless steel cylinder or a heat exchanger in a 52H cylinder.

pH is a measure of whether the water is alkaline or acid. In an acidic water supply, the water can attack stainless steel parts and cause them to fail.

Where the pH is less than 6.0 the Rheem warranty does not apply to a stainless steel cylinder or a heat exchanger in a 52H cylinder. Water with a pH less than 6.0 may be treated to raise the pH.

The water supply from a rainwater tank in a metropolitan area is likely to be corrosive due to the dissolution of atmospheric contaminants. This may result in pH of less than 6.0. It is recommended an analysis on the water from a rainwater tank be conducted prior to connecting this type of water supply to a water heater with a stainless steel cylinder.

Refer to the [pH and Chloride chart](#) on page 19.

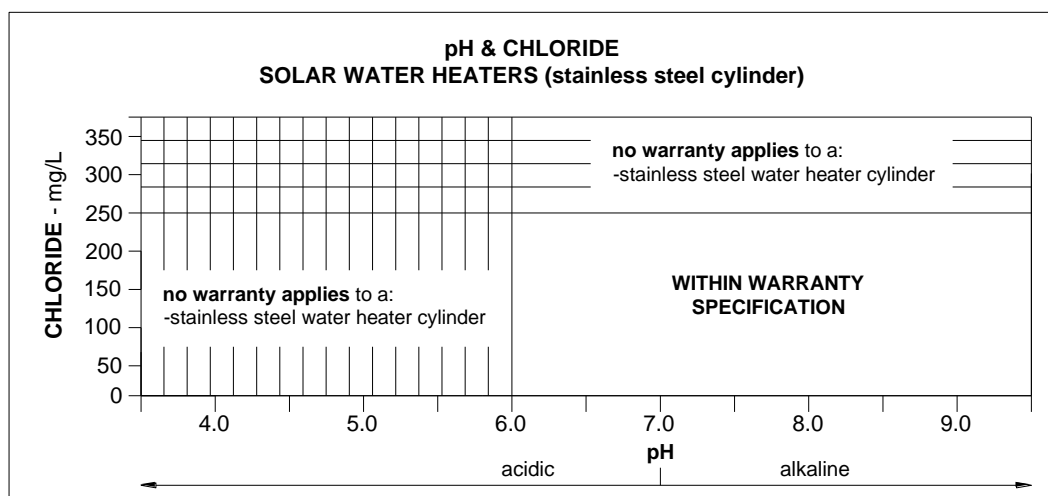

SATURATION INDEX

The saturation index is used as a measure of the water’s corrosive or scaling properties. The saturation index figures stated are calculated using a water temperature of 80°C.

In a corrosive water supply, the water can attack copper parts and cause them to fail. Where the saturation index is less than -1.0, the water is very corrosive and the Rheem warranty does not apply to a copper sheathed heating unit or a solar collector in a direct solar water heater system. A corrosion resistant heating and an indirect solar water heater must be used unit must be used for the Rheem warranty to apply to the heating unit and solar collector. This water heater is supplied fitted with a corrosion resistant heating unit.

In a scaling water supply calcium carbonate is deposited out of the water onto any hot metallic surface.

Where the saturation index exceeds +0.40, the water is very scaling. An expansion control valve must be fitted on the cold water line after the non-return valve to protect and for the Rheem warranty to apply to the temperature pressure relief valve and water heater cylinder. Solar collectors in a direct solar water heater system should be covered when the water heater is not intended to be used for more than two weeks.

Where the saturation index exceeds +0.80, the Rheem warranty does not apply to a standard watts density heating unit or a solar collector in a direct solar water heater system. A low watts density heating unit or an indirect solar water heater must be used for the Rheem warranty to apply to the heating unit or solar collector.

Water which is scaling may be treated with a water softening device to reduce the saturation index of the water.

Refer to the [Saturation Index chart](#) on page 20. Refer to the [cold water connection detail on page 56](#) for the position of the expansion control valve.

Contact Rheem Service or their nearest Accredited Service Agent if a replacement heating unit is required.

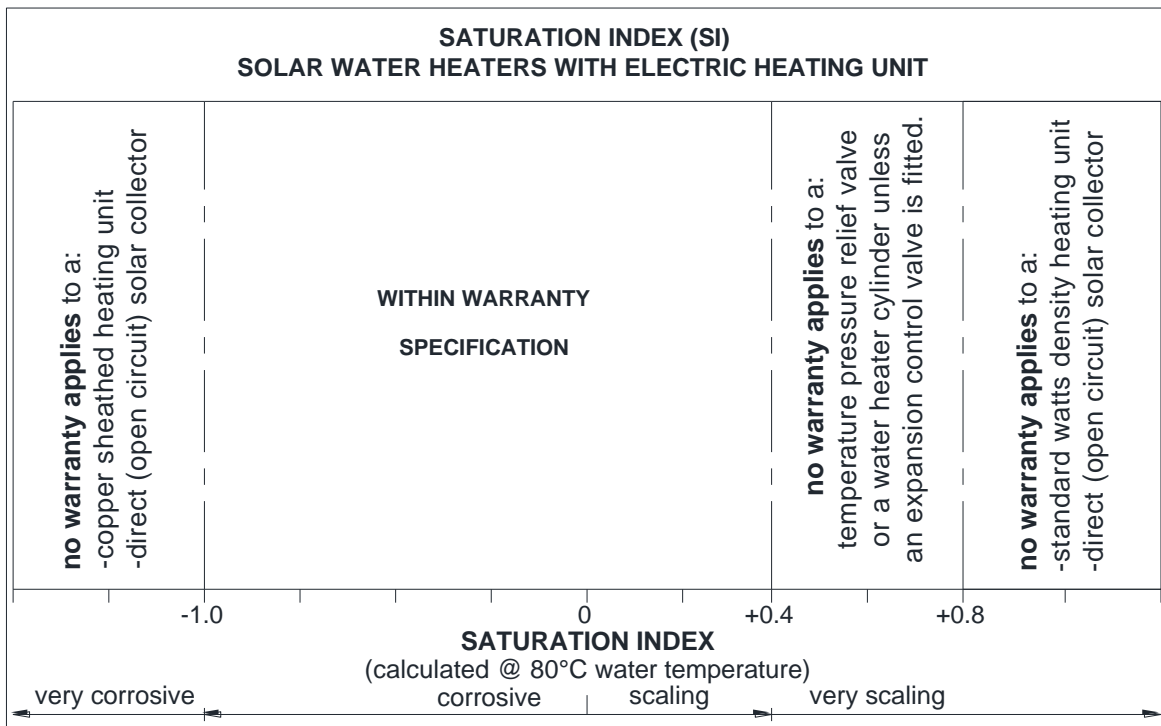

SUMMARY OF WATER CHEMISTRY ADVICE AFFECTING WARRANTY

The water heater and its components are not suitable for certain water chemistries. Those chemistries are listed below. If the water heater is connected at any time to a water supply with the following water chemistry, the Rheem warranty will not cover any resultant faults on the components listed below:

Water Chemistry

Chloride > 250 mg/L

pH < 6.0

Saturation Index (SI) < -1.0

Saturation Index (SI) > +0.4
(if an expansion control valve is not fitted)

Saturation Index (SI) > +0.8

Component

water heater cylinder and heat exchanger

water heater cylinder and heat exchanger

solar collector in a direct system
copper sheathed heating unitwater heater cylinder and heat exchanger
temperature pressure relief valvesolar collector in a direct system
standard watts density heating unit

SAVE A SERVICE CALL

Check the items below before making a service call. You will be charged for attending to any condition or fault that is not related to manufacture or failure of a part.

NOT ENOUGH HOT WATER (OR NO HOT WATER)

This can occur with new installations and is normally related to some misunderstandings as to the use of the booster heating unit.

- **Insufficient sunlight**

Insufficient sunlight due to cloudy weather during hotter months or low solar energy contribution in colder months may mean the booster heating unit is required to boost more often.

Ensure the booster heating unit is being used as advised. Refer to **“Booster Control”** on page 14.

- **Booster heating unit not operating**

Inspect the isolating switch marked “HOT WATER” or “WATER HEATER” at the switchboard and ensure it is turned on.

Check the timer (if one is installed) and its settings to ensure power is available to the booster heating unit.

Note: Check the electricity supply to which the unit is connected. If on an Off-Peak or time controlled electricity supply remember heating hours are restricted.

Check the fuse or circuit breaker marked “HOT WATER” or “WATER HEATER” at the switchboard.

- **Collectors shaded**

If trees or other objects shade the solar collectors or if the glass is dirty, the effectiveness of the solar collectors will be greatly reduced.

Have the trees trimmed or the solar collectors relocated if the obstruction is permanent or clean the collector glass.

Refer to **“Collector Glass”** on page 18.

- **Are you using more hot water than you think?**

Is one outlet (especially the shower) using more hot water than you think?

Very often it is not realised the amount of hot water used, particularly when showering. Carefully review the family’s hot water usage. As you have installed an energy saving appliance, energy saving should also be practised in the home. Adjust your water usage pattern to take advantage of maximum solar gains.

Have your plumber install a flow control valve to each shower outlet to reduce water usage.

- **Relief valve running**

Is the relief valve discharging too much water?

Refer to **“Temperature Pressure Relief Valve or Expansion Control Valve Running”** on page 23.

- **Thermostat setting**

Ensure the thermostat setting is appropriate. You may choose to have your electrician adjust the thermostat upwards to gain additional hot water capacity when boosting.

Refer to **“Temperature Adjustment”** on page 13.

⚠ Warning: Hotter water increases the risk of scald injury.

- **Water heater size**

Do you have the correct size water heater for your requirements?

The sizing guides in the sales literature and on the Rheem website (www.rheem.com.au) suggest average sizes that may be needed.

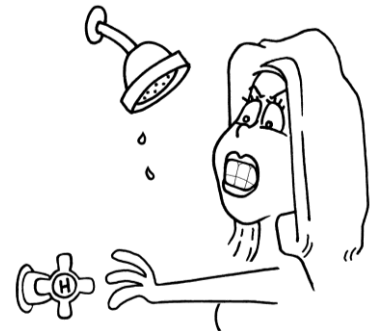

WATER NOT HOT ENOUGH

You may find that due to heavy hot water usage or low solar energy gain the water temperature may be lower than normally expected. Ensure the booster is being used as advised. If a timer is installed, you will need to carefully plan your use of the booster heating unit to boost the water temperature on such occasions.

Temperature Redistribution: A lower water temperature may be noticed in the morning when the booster heating unit has not been energised overnight. This temperature reduction is caused by the transfer of heat energy overnight from the hot water in the upper part of the solar storage tank to the cold water in the lower part of the solar storage tank. This effect is often perceived as heat loss but is actually the redistribution of stored heat more evenly over the entire contents of the solar storage tank. This heat is not lost to the system.

Temperature redistribution is more prevalent the more hot water is used the night before or if the booster switch or time clock is left off over-night and in particular may be experienced during periods of low solar energy gain, such as during the cooler months. Temperature redistribution can also occur during days of lower solar radiation particularly during the cooler months if power to the booster heating element is not available, or the booster switch or time clock is left off.

If higher temperature water is required, particularly in the morning, then use of the booster heating unit is necessary to raise the temperature of the water in the top section of the cylinder.

If the water heater is connected to an Off-Peak (overnight) electricity supply, then switching to an Extended Off-Peak (overnight and day) supply should be considered. If a timer is being utilised, then a timed boost period in the afternoon prior to the evening usage should be considered.

Refer also to “**Booster Control**” on page 14.

TEMPERATURE PRESSURE RELIEF VALVE OR EXPANSION CONTROL VALVE RUNNING

- **Normal Operation**

It is normal and desirable the temperature pressure relief valve or expansion control valve allows a quantity of water to escape during the heating cycle. This quantity should be equal to approximately 1/50 of the hot water used, as water expands by this volume when heated. However, if it discharges more than a bucket full of water in 24 hours, there may be another problem.

The expansion control valve will discharge water instead of the temperature pressure relief valve as it has a lower pressure rating. A benefit is that energy is conserved as the discharged water is cooler. This valve is installed in the cold water line to the water heater (refer to the **cold water connection diagram** on page 56).

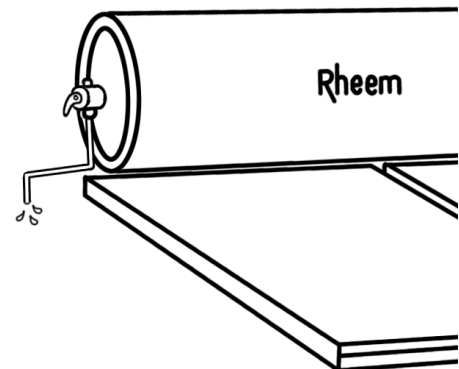

- **Continuous dribble**

Try gently raising the easing lever on the relief valve for a few seconds (refer to “**Relief Valves**” on page 9). This may dislodge a small particle of foreign matter and clear the fault. Release the lever gently.

If the relief valve lever is not readily and safely accessible, contact Rheem Service or their nearest Accredited Service Agent. Do not attempt to climb onto a non-trafficable roof to operate the relief valve lever.

- **Steady flows for long period (often at night)**

This may indicate the mains water pressure sometimes rises above the designed pressure of the water heater. Ask your installing plumber to fit a pressure limiting valve.

⚠ Warning: Never replace the relief valve with one of a higher pressure rating.

- **Heavy flows of hot water from the temperature pressure relief valve until the water heater is cold - then stops until water reheats**

If this occurs when the water heater is being boosted by the electric booster heating unit, then the water heater **must** be switched off at the isolating switch or switchboard. Phone Rheem Service or their nearest Accredited Service Agent to arrange for an inspection.

This may also occur on a water heater without an over temperature protection (OTP) system during periods of increased solar gain in the hotter months and particularly if there is a reduced level of hot water consumption. It is most likely to happen during the daytime.

The temperature pressure relief valve will discharge water if the water temperature increases to a very high level under these conditions. This higher temperature water is replaced with incoming cold water to reduce the energy level inside of the tank. The valve will close when cooler water surrounds the temperature probe of the valve. As this is a function of the temperature pressure relief valve under these conditions, it is not necessary to make a service call, however you may consider having an over temperature protection (OTP) system installed.

COLLECTOR GLASS

The Rheem warranty **DOES NOT** cover breakage of solar collector glass. Check your household insurance policy covers collector glass breakage.

⚠ Warning: No attempt should be made to remove or replace broken collector glass.

The collector glass is not offered as a replacement part. Should the solar collector require replacement, contact Rheem Service or their nearest Accredited Service Agent.

HIGHER THAN EXPECTED ELECTRICITY BILLS

With the installation of your new solar hot water system, maximum electrical energy savings can be achieved with careful planning of hot water usage. Should you at any time feel your electricity bill is higher than expected, we suggest you check the following points:

- Is the relief valve running excessively?

Refer to **“Temperature Pressure Relief Valve or Expansion Control Valve Running”** on page 23.

- Is one outlet (especially the shower) using more hot water than you think?

Refer to **“Not Enough Hot Water”** on page 22.

- Is there a leaking hot water pipe, dripping hot water tap, etc?

Even a small leak will waste a surprising quantity of hot water and energy. Replace faulty tap washers, and have your plumber rectify any leaking pipe work.

- Are you using the booster heating unit properly?

Refer to **“Booster Control”** on page 14.

- Has there been an increase in hot water usage?

An increase in hot water usage may result in an increase in booster operation.

- Has your water heating tariff rate been increased by your electricity retailer since your previous bill?

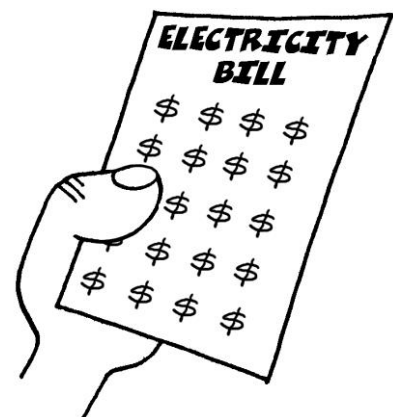

ELECTRICITY TARIFFS

The electricity tariff to which your solar water heater is connected will play an important role in the overall effectiveness of the system. It is important you are aware of this tariff to enable you to take full advantage of the boosting period, i.e. Domestic / Continuous or Time of Use, Extended Off-Peak (overnight and day) or extended time controlled, or Off-Peak (overnight) or time controlled.

The electricity tariff will impact on the operating costs of the system. Time controlled tariffs are generally cheaper than a continuous supply tariff and result in lower running costs.

IF YOU HAVE CHECKED ALL THE FOREGOING AND STILL BELIEVE YOU NEED ASSISTANCE, PHONE RHEEM SERVICE OR THEIR NEAREST ACCREDITED SERVICE AGENT.

INSTALLATION

THIS WATER HEATER IS NOT SUITABLE FOR POOL HEATING.

SOLAR COLLECTORS

The 52L tank is suitable for installation with NPT200, L or CSA2007 solar collectors and the 52H tank is suitable for installation with SPA2000, NPT200, L or CSA2007 solar collectors.

In Australia, 52H systems with NPT200, L and SPA2000 collectors are suitable for installation in all climate zones, whilst 52L systems with NPT200 and L collectors are suitable for installation in climate zones 1, 2 and 3 in areas not subject to freeze conditions.

In Australia for climate zones 1, 2, and 3 there is a risk that systems with CSA2007 collectors may over perform. We recommend in climate zones 1, 2, and 3, that CSA2007 systems with 2 or more collectors only be installed at orientations between 60° and 90° from the equator.

In Australia in climate zone 4, systems with selective surface CSA2007 collectors provide optimum performance compared with non-selective surface collectors, particularly in the months of lower solar radiation.

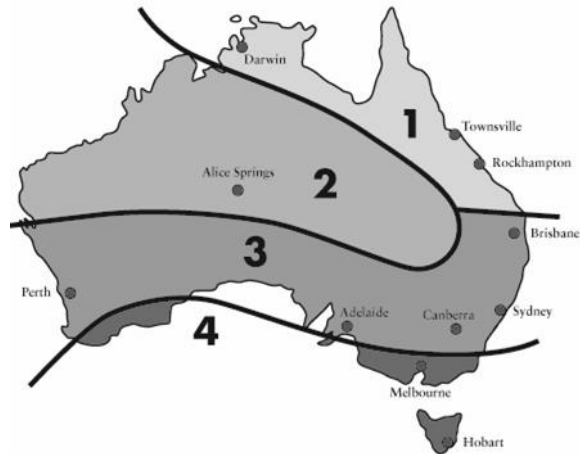

IMPORTANT NOTES

- Working on roofs is and should always be considered a hazardous activity, particularly early in the morning, late in the evening, when the roof is wet or during and after periods of rain.
- All work must be carried out in accordance with Local, State and Federal Occupational Safety, Health and Welfare Regulations. In particular, the requirements for safety whilst manual lifting, working at heights and on roofs.
- Installers must be competently trained in:
 - Height Hazard Assessment
 - Working at Height Procedures
 - Assessment / Use / Wearing of correct height safety equipment (harnesses etc.)
 - All other relevant safety factors specific to the installation and maintenance work to be compliant with suitable Occupational, Health and Safety Regulations / Codes.
- All relevant permits shall be obtained from the regulatory authorities before commencing work to install the solar hot water system.
- All work carried out must be performed by appropriately qualified tradespeople or be suitably supervised for trades assistant duties.
- Every care must be taken to protect and warn occupants of the building and the public from personal injury which may occur from falling tools, roof materials, fittings or any other hazards of a general nature.
- Advise the occupants of any inconvenience which may occur due to disconnection of existing water and electrical supplies.
- The connection, attachment, integration or general association of other equipment or parts which either directly or indirectly affect the operation or performance of this equipment could void the Rheem warranty.
- All packaging materials must be removed from the solar storage tank prior to its installation. Refer to the **warning** on page 46 in relation to the removal of the solar collector packaging.

INSTALLATION STANDARDS

The water heater must be installed:

- by a qualified person, and
- in accordance with the installation instructions, and
- in compliance with the Plumbing Code of Australia (PCA), Standards AS/NZS 3500.4 and AS/NZS 3000, and all local codes and regulatory authority requirements.
- In New Zealand, the installation must conform with Clause G12 of the New Zealand Building Code.

⚠ Warning: This water heater may deliver water at high temperature. Refer to the Plumbing Code of Australia, local requirements and these installation instructions to determine if additional delivery temperature control is required. Refer to “**Hot Water Delivery**” on page 29.

Victorian Installers

Notice to Victorian Installers from the Victorian Building Authority if this solar water heater is installed in a new Class 1 dwelling in the State of Victoria. The system model number is to be recorded on the Certificate of Compliance.

It is also a requirement to provide the householder with permanent documentation recording the system model number exactly as it is shown in the ‘VEET Product Register’ published by the Essential Services Commission in Victoria. See www.veu-registry.vic.gov.au/Public/ProductRegistrySearch.aspx. This documentation may be in the form of an indelible label adhered to the solar storage tank, or other suitable form placed in an accessible location, such as the meter box, for later inspection.

PACKING, STORAGE AND TRANSPORTATION

All Thermosiphon products are to be kept in the original packaging materials and should be transported or stored in the vertical position - note there is an arrow to indicate the ‘UP’ direction for Tanks. They may be stored horizontally in the correct orientation, as shown on the packaging, if handled carefully with correct lifting equipment.

SYSTEM DECOMMISSIONING

Decommissioning of the system should be undertaken by an installer or suitable qualified plumber and / or electrician (if required). All materials used in this product can be passed to your local material recycling centre for disposal - refer to local council regulations for details.

WATER HEATER APPLICATION

This water heater is designed for use in a single family domestic dwelling for the purpose of heating potable water. Its use in an application other than this may shorten its life.

If this water heater is to be used where an uninterrupted hot water supply is necessary for the application or business, then there should be redundancy within the hot water system design. This should ensure the continuity of hot water supply in the event that this water heater was to become inoperable for any reason. We recommend you provide advice to the system owner about their needs and building backup redundancy into the hot water supply system.

This water heater is designed to be installed as an electric boosted solar water heater with its booster heating unit connected to a power supply, however it may be installed with an in-series continuous flow or storage booster. If this water heater is installed with an in-series booster, then the electric booster heating unit will not be connected to a power supply and the references to the electric booster heating unit, thermostat and boosting controls in these installation instructions will not be applicable to the installation.

Note: AS 3498 requires that a water heater provides the means to inhibit the growth of Legionella bacteria in potable water. This water heater can satisfy this AS 3498 requirement provided the electric booster is energised for a sufficient period each day and the electric booster thermostat setting is 60°C or higher.

If this water heater is installed with an in-series continuous flow gas booster, then this requirement of AS 3498 can be satisfied provided the booster is energised, its preset outlet temperature setting is 70°C or higher and a remote temperature controller is not used.

If this water heater is installed with an in-series storage booster, then this requirement of AS 3498 can be satisfied provided the storage booster is energised and its thermostat setting is 60°C or higher.

Installing the Water Heater as a Pre-Heater

This water heater can be used as a pre-heater to a new or existing in-series booster water heater provided:

- The in-series booster water heater is;
 - thermostatically-controlled, and
 - suitable to be used as an in-series booster water heater for a solar water heater.
- The operating pressures of the two water heaters are compatible or reduced to the lower rated of the two water heaters
- The in-series booster water heater has sufficient thermal capacity to supply the hot water requirements of the application during periods of low or no solar gain.
- A temperature-operated bypass valve is installed prior to the in-series water heater if this water heater has either an over temperature energy cut-out which can be permanently disabled by high temperature hot water or a maximum recommended inlet supply temperature less than the temperature of water which can be supplied by this solar water heater.

It will be necessary to check with the manufacturer of the in-series water heater as to its suitability for use as an in-series booster to this solar water heater.

FREEZE PROTECTION

The 52H series systems are suitable for installation in areas subject to frost or freeze conditions and is protected against these conditions by its closed circuit fluid. The closed circuit fluid concentrate is used to lower the freezing temperature of the closed circuit fluid and provides protection against freezing. Freeze conditions occur below 6°C. Only closed circuit fluid concentrate supplied by Rheem is permitted to be used in the closed circuit system.

The 52H series systems are supplied with Coolblend heat transfer fluid concentrate. During installation and commissioning the Coolblend concentrate is blended with water in the appropriate proportion to achieve the required frost protection. The [table on page 66](#) lists the percentage of Coolblend concentrate fluid in the closed circuit of each system and the recommended minimum ambient temperature for the system, for the number of bottles supplied with each system. If a lower temperature protection is required, additional Coolblend concentrate will be needed. It is recommended the storage cylinder be filled with water before charging the closed circuit with closed circuit fluid. Refer to [“Closed Circuit Fluid”](#) on page 66.

The system has NO WARRANTY for freeze damage if non Rheem approved closed circuit fluid has been used or if the closed circuit fluid has been incorrectly mixed (refer to [“Terms of the Rheem Warranty”](#) on page 4).

Note: The 52L series systems do not have freeze protection. These systems are not suitable for installation in areas subject to frost or freeze conditions. Freeze conditions occur below 6°C. The system has NO WARRANTY for freeze damage (refer to [“Terms of the Rheem Warranty”](#) on page 4).

SOLAR WATER HEATER STORAGE TANK LOCATION

The solar storage tank is designed to be installed on the roof directly coupled to the solar collectors. The solar water heater should be installed close to the most frequently used outlet and its position chosen with safety and service in mind. The solar water heater should be installed with a north facing aspect (refer to [“Solar Collector Location”](#) on page 40).

The solar water heater must not be installed with an inclination of less than 10° or greater than 45°. The water heater may not thermosiphon or will not perform efficiently.

Clearance must be allowed for servicing of the solar storage tank. Make sure the temperature pressure relief valve lever is accessible and the side cover, thermostat and booster heating unit can be removed for service. You must be able to read the information on the rating plate.

Remember you may have to remove the entire solar storage tank later for servicing. The solar storage tank must be capable of being removed without structural alteration to the building or major alteration to the piping.



For a single water heater installation, refer to the [diagrams on pages 35 and 36](#). For multiple water heater installations, follow the [instructions on pages 63 and 64](#).

MAINS WATER SUPPLY

Where the mains water supply pressure exceeds that shown in the table below, an approved pressure limiting valve is required and should be fitted as shown in the [cold water connection diagram](#) on page 56.

Model	180, 300
Temperature pressure relief valve setting	850 kPa
Expansion control valve setting *	700 kPa
Maximum mains supply pressure	
With expansion control valve	550 kPa
Without expansion control valve	680 kPa

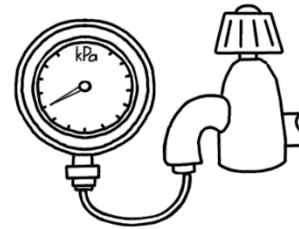

* Expansion control valve is supplied with the water heater installation parts kit

TANK WATER SUPPLY

If the water heater is supplied with water from a tank supply and a pressure pump system is not installed, then the bottom of the supply tank must be at least 1 m above the highest point of the hot water plumbing system, including the water heater. Care must be taken to avoid air locks. The cold water line to the water heater should be adequately sized and fitted with a full flow gate valve or ball valve.

RAINWATER COLLECTION SYSTEM

Before installing a closed circuit system, the installer should determine whether rainwater runoff from the roof on which the system will be mounted, is collected in a rainwater tank. If a 52H series system is to be installed on a section of roof which is part of a rainwater collection system, then it is recommended this section of roof and its gutter be isolated from the rainwater collection system. The gutter should be isolated to a width greater than the solar collectors and pipe work and must have suitable drainage. The installer should ensure in the event of a leak from the closed circuit, a rainwater tank cannot be contaminated with closed circuit fluid.

The closed circuit fluid acts as an anti-freeze agent and rust inhibitor, is non-toxic to humans and is harmless to the environment. However it does have an adverse effect on water stored in rainwater tanks. It will kill microscopic algae typically present in rainwater tanks and cause an unpleasant odour to develop. This will result in the rainwater tank having to be drained and cleaned.

The section of roof and gutter should be isolated from the rainwater collection system before the commissioning of the solar water heater, so that any leak or spillage during commissioning does not make its way into the rainwater tank.

The installer should discuss alternative options to suit the installation with the householder. Any alterations to the roof drainage system must comply with the relevant building regulations, codes and Standards.

Refer to [“Rainwater Collection System”](#) on page 15 for additional information on what to do if a rainwater tank does become contaminated with closed circuit fluid.

WATER CHEMISTRY

The system is not suitable for installation in areas with harsh water chemistry. The system has NO WARRANTY for damage caused by harsh water chemistry.

Refer to [“Water Supplies”](#) on page 19 for information on the water chemistry limits which apply to the water heaters.

HOT WATER DELIVERY

⚠ Warning: The water heater can deliver hot water under normal use and summer solar conditions at a temperature of 60°C to 75°C. This water temperature can be exceeded and reach up to around 90°C during periods of high solar radiation conditions and reduced hot water usage. These temperatures are sufficiently hot to cause severe scalding. Water at this temperature may be plumbed to fixtures where water hotter than 50°C is allowed, such as the kitchen and laundry, after ensuring all pipe work, fixtures and fittings are suitable for at least 95°C.

The installing plumber may have a legal obligation to ensure the installation of this water heater meets the water temperature delivery requirements of the Plumbing Code of Australia so that heated water delivered to fixtures and appliances used primarily for personal hygiene is at a temperature which is unlikely to scald.

It is necessary and we recommend that a temperature limiting device be fitted between the water heater and the fixtures and appliances used primarily for personal hygiene such as in a bathroom, ensuite, public amenities or other ablution areas, to reduce the risk of scalding.

The temperature limiting device must be of a type suitable for use with a solar water heater. Refer to the manufacturer’s specifications of the temperature limiting device.

If there is a separate higher temperature hot water line to a non-ablution area or if a tempering valve is not required, then a primary temperature control valve can be installed to reduce the temperature after the water heater if a 75°C or greater delivery temperature is considered by a consumer to be too high for their needs or the plumbing materials used in the heated water system are not rated to carry 75°C or higher water temperature.

Where a temperature limiting device is installed adjacent to the solar water heater, the cold water line to the temperature limiting device can be branched off the cold water line either before or after the isolation valve, non-return valve and pressure limiting valve to the water heater.

The expansion control valve must always be installed after the non-return valve and be the last valve prior to the solar storage tank.

If a pressure limiting valve is installed on the cold water line to the solar water heater and the cold water line to a temperature limiting device branches off before this valve or from another cold water line in the premises, then a pressure limiting valve of an equal pressure setting may be required prior to the temperature limiting device.

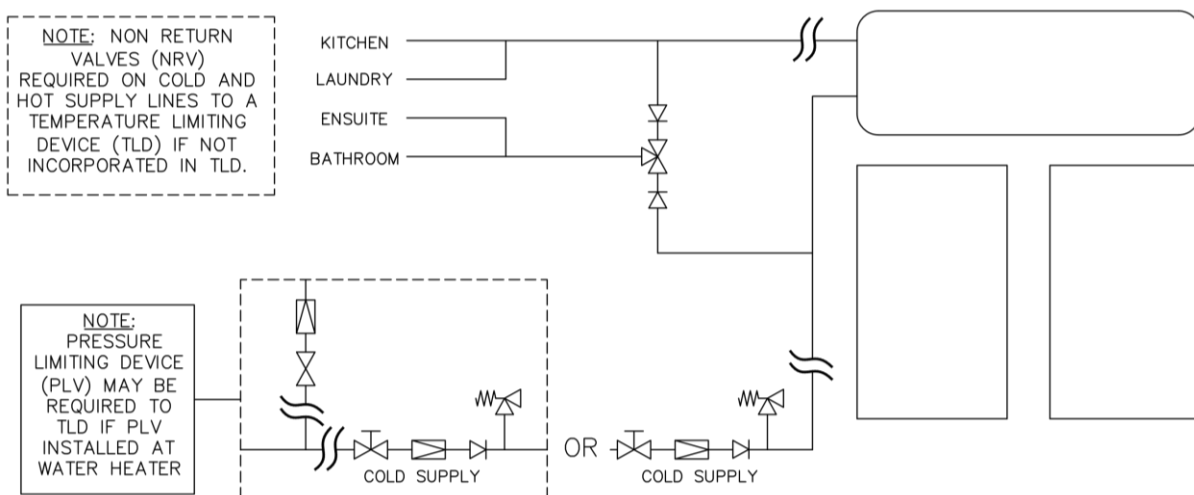

Two Temperature Zones Using a Temperature Limiting Device

CIRCULATED HOT WATER FLOW AND RETURN SYSTEM

A solar water heater should not be installed as part of a circulated hot water flow and return system in a building. The benefits of solar gain will be significantly reduced.

In-tank electric boosting

If this solar water heater has its electric heating unit connected for in-tank boosting and a circulated flow and return system is required, it is necessary to install a secondary water heater supplied from the solar water heater. The flow and return lines connect to the secondary water heater, not the solar storage tank. The secondary water heater makes up for the pipe heat loss in the flow and return system and must be able to provide a hot water outlet temperature of at least 60°C.

Refer to the diagram [Circulated Hot Water Flow and Return System – Solar Water Heater with In-tank Boosting](#) on page 30.

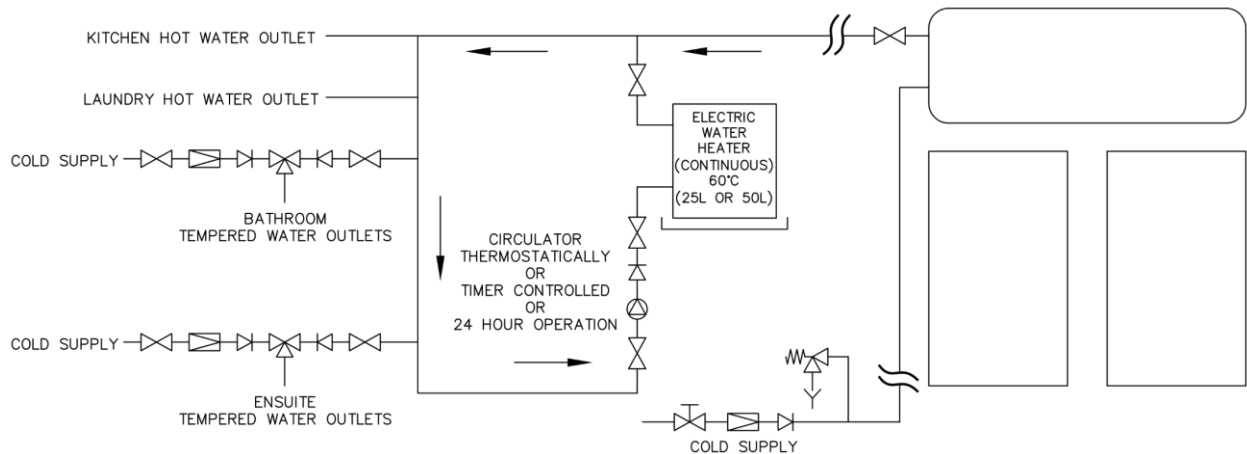

A PLV is required to be installed on the cold supply line to the tempering valve if a PLV is installed in the cold supply line to the water heater.

Circulated Hot Water Flow and Return System – Solar Water Heater with In-tank Boosting

In-series boosting

If this solar water heater does not have its electric heating unit connected for in-tank boosting and is installed as a solar pre-heater to an in-series booster water heater, then the booster water heater can be used as the secondary water heater so long as it is able to provide a minimum hot water outlet temperature of at least 60°C and it is not connected to an Off-Peak or time controlled electricity supply. It is necessary to connect the flow and return lines to the in-series booster and not to the solar storage tank.

Refer to the diagram [Circulated Hot Water Flow and Return System – Solar Water Heater with In-series Boosting](#) on page 31.

If the in-series water heater is a continuous flow water heater, the circulator must be:

- sized and set to provide a minimum flow rate of 3.0 L/min through the circulated hot water flow and return system, and
- either thermostatically and / or timer controlled.

The circulator **must not** be set to operate continuously, i.e. 24 hours per day.

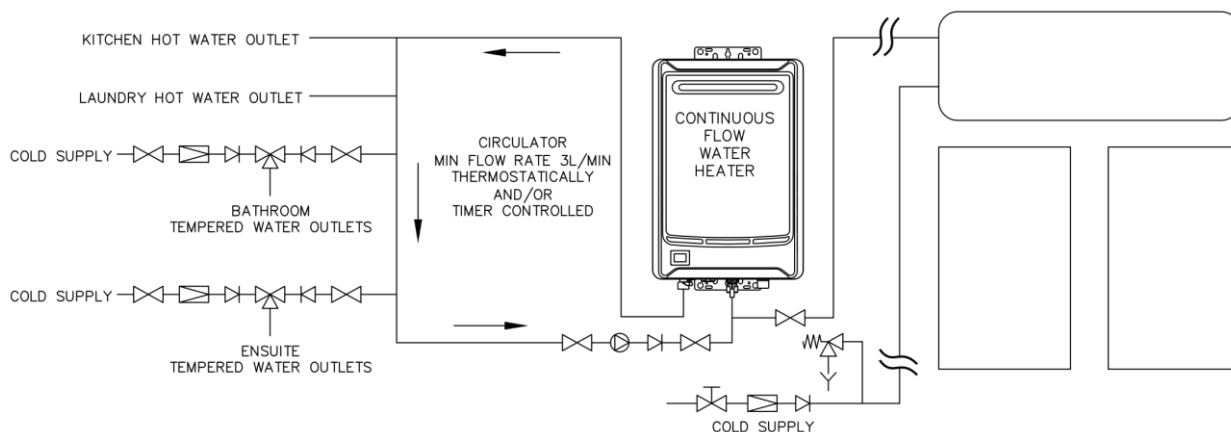

A PLV is required to be installed on the cold supply line to the tempering valve if a PLV is installed on the cold supply line to the water heater.

Circulated Hot Water Flow and Return System – Solar Water Heater with In-series Boosting

Temperature Settings

- AS 3498 requires that a water heater provides the means to inhibit the growth of Legionella bacteria in potable water. To meet this requirement of AS 3498:
 - A solar storage tank with its electric heating unit connected for in-tank boosting, and the secondary water heater must always have their thermostats set to at least 60°C
 - An in-series storage water heater must always have its thermostat set to at least 60°C
 - An in-series continuous flow water heater must always have its preset outlet temperature setting set to at least 70°C
- Water should not be circulated from a water heater with a temperature setting of less than 60°C.
- The return water temperature to the water heater must not be less than 55°C.
- If the water temperature decreases by more than 5°C due to heat loss from the ring main, the preset outlet temperature setting or thermostat setting of the secondary water heater or in-series water heater must be set to above 60°C to ensure the return water temperature is not less than 55°C.

Temperature Limiting Device

A temperature limiting device cannot be installed in circulated hot water flow and return pipe work. The tempered water from a temperature limiting device cannot be circulated. Where a circulated hot water flow and return system is required in a building, a temperature limiting device can only be installed on a dead leg, branching off the circulated hot water flow and return pipe.

If circulated tempered water were to be returned back to the water heater, depending on the location of the return line connection on the water supply line to the water heater, then either:

- water will be supplied to the cold water inlet of the temperature limiting device at a temperature exceeding the maximum recommended water supply temperature, or
- when the hot taps are closed no water will be supplied to the cold water inlet of the temperature limiting device whilst hot water will continue to be supplied to the hot water inlet of the temperature limiting device.

These conditions may result in either water at a temperature exceeding the requirements of the Plumbing Code of Australia being delivered to the hot water outlets in the ablution areas, or the device closing completely and not delivering water at all, or the device failing. Under either condition, the operation and performance of the device cannot be guaranteed.

REDUCING HEAT LOSSES

The cold water line to and the hot water line from the water heater must be insulated in accordance with the requirements of AS/NZS 3500.4. The insulation must be weatherproof and UV resistant if exposed.

The pipe work between the solar storage tank and the solar collectors may be required to be insulated. Refer to “Warning: Plumber Be Aware” on page 42.

SADDLING - PIPE WORK

To prevent damage to the cylinder when attaching pipe clips or saddles to the solar storage tank jacket, we recommend the use of self-drilling screws with a maximum length of 13 mm. Should pre-drilling be required, extreme caution must be observed when penetrating the jacket of the solar storage tank.

Note: If the cylinder is damaged as a result of attaching pipe clips or saddles to the jacket, any resultant faults will not be covered by the Rheem warranty.

BOOSTER HEATING UNIT

The booster heating unit is for heating the water at times of low solar energy gain, such as during very cloudy or rainy weather, or during the colder months. Refer to “Connections – Electrical” on page 60 for electrical connection requirements and control options of the booster heating unit.

If this water heater is installed with an in-series booster, then the electric booster heating unit in the solar storage tank will not need to be connected to a power supply.

PLASTIC END COVER

A set of plastic end covers is available for installation to the ends of the tank. These ends provide an aesthetically pleasing finish to the system by housing the pipe work and electrical connection within them.

Where a plastic end cover is to be installed, the plumbing and electrical connections need to be routed to suit. Check the installation documentation that comes with the plastic ends for these details.

TANK REPLACEMENT

If replacing a tank, the replacement tank must be fitted with a new temperature pressure relief valve and expansion control valve. These valves are not supplied with the tank.

OVER-TEMPERATURE PROTECTION

AS/NZS 2712:2007 includes a requirement for a no-load system operation test. In order to comply with this requirement, 52L series systems installed with CSA2007 collector(s) must be fitted with TRV, and 52H series systems installed with two or more CSA2007 collectors must be fitted with OTP.

The systems listed below must be installed using the Over-Temperature Protection Parts Kits described to comply with AS/NZS 2712:2007.

52L Series System Over-Temperature Protection

The following systems require the installation of a Thermosiphon Restrictor Valve (TRV) kit to meet the requirements of AS/NZS 2712:2007.

System Number	Parts Kit No.	No. of Collectors
52L180/1CS07	12103101	1 collector
52L300/2CS07	12103103	2 collectors

Please refer to the “System Assembly” section of these installation instructions or those supplied with the Parts Kit for TRV installation details.

52H Series System Over-Temperature Protection

The following systems require the installation of an OTP kit to meet the requirements of AS/NZS 2712:2007:

System Number	Parts Kit No.	No. of Collectors
52H300/2CS07	12103113	2 collectors
52H300/3CS07	12103115	3 collectors

Please refer to the specific OTP Installation Instructions (347199) supplied in these OTP Parts Kits for installation details.

DIMENSIONS AND TECHNICAL DATA

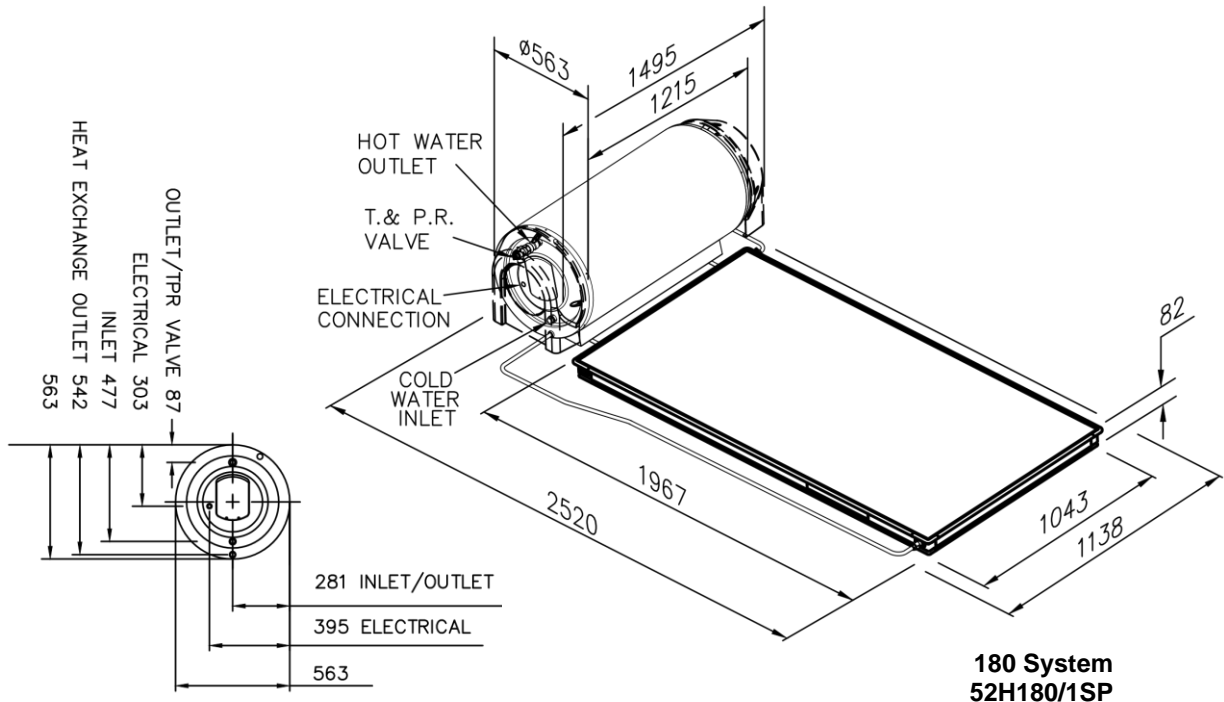

**180 System
52H180/1SP**

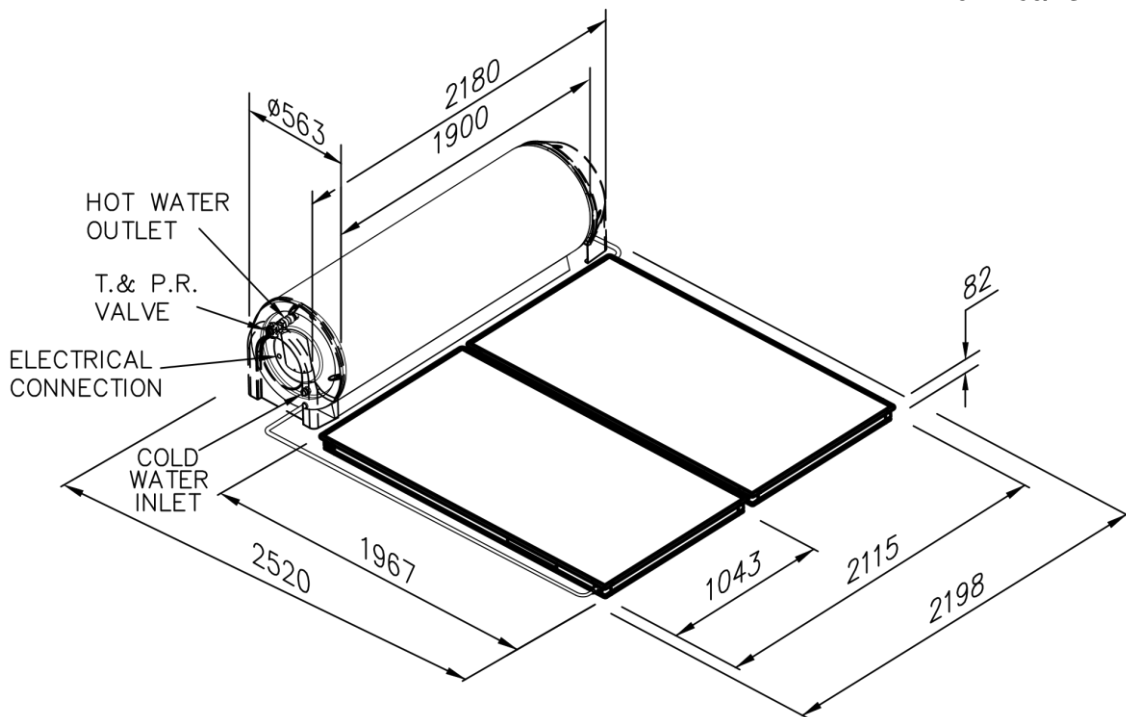

**300 System
52H300/2SP**

Direct System Data

Direct System	Type	Solar Storage Tank				Solar Collectors				Parts Kit	System
		Model	Nominal Capacity (litres)	Empty (kg) cartoned	Full (kg)	Model	Qty	Empty (kg)	Full (kg)	Weight (kg)	Full (kg)
52L180/1 NPT or L or CS07	open circuit	52L180	180	49	226	NPT200	1	36	38	6	271
						L		29	31	6	264
						CSA2007		36	36	7	272
52L300/2 NPT or L or CS07	open circuit	52L300	300	73	369	NPT200	2	72	75	8	453
						L		58	61	8	439
						CSA2007		72	75	9	454

Technical data is subject to change.

Tank model number has a four digit suffix to denote the heating unit size and jacket colour, e.g. 52L300M775, where:

M5 = 2.4kW, M7 = 3.6kW

25 = Night Sky, 35 = Manor Red, 75 = Silver Grey, 80 = Woodland Grey

Indirect System Data

Indirect System	Type	Solar Storage Tank				Solar Collectors				Parts Kit	System
		Model	Nominal Capacity (litres)	Empty (kg) cartoned	Full (kg)	Model	Qty	Empty (kg)	Full (kg)	Weight (kg)	Full (kg)
52H180/1 NPT or L or CS07	closed circuit	52H180	180	54	231	NPT200	1	36	38	6	276
						L		29	31	6	269
						CSA2007		36	36	11	281
52H300/2 NPT or L or CS07	closed circuit	52H300	300	81	377	NPT200	2	72	75	8	461
						L		58	61	8	447
						CSA2007		72	75	13	466
52H300/3 NPT or L or CS07	closed circuit	52H300	300	81	377	NPT200	3	108	113	10	501
						L		87	92	10	480
						CSA2007		108	113	16	507
52H180/1SP	closed circuit	52H180	180	54	231	SPA2000	1	45	49	6	287
52H300/2SP	closed circuit	52H300	300	79	377	SPA2000	2	90	98	8	484

Technical data is subject to change.

Tank model number has a four digit suffix to denote the heating unit size and jacket colour, e.g. 52H300M775, where:

M5 = 2.4kW, M7 = 3.6kW

25 = Night Sky, 35 = Manor Red, 75 = Silver Grey, 80 = Woodland Grey

Collector Data

Feature		NPT200	L	CSA2007	SPA2000
Aperture	m ²	1.87	1.87	1.87	1.87
Capacity	litres	1.5	1.5	1.5	4.0
Length x Width x Height	mm	1938 x 1024 x 80	1943 x 1027 x 83	1996 x 1043 x 82	1996 x 1043 x 82
Working pressure	kPa	1000	1000	1000	200
Weight – empty	kg	36	29	36	45
No of risers		7	7	7	35
Riser material		Copper	Copper	Copper	Steel
Absorber material		Aluminium	Aluminium	Copper	Steel
Absorber surface		Black polyester powder coat	Black polyester powder coat	Blue Tinox selective surface	Black polyester powder coat
Tray material – sides and underside		Zincalume Steel 0.55 mm	Aluminium 0.7 mm	N/A	N/A
Frame material		N/A	N/A	Extruded Aluminium	Extruded Aluminium
Underside sheeting		N/A	N/A	Zincalume Steel 0.4 mm	Zincalume Steel 0.4 mm
Insulation material		Polyester: 38 mm	Polyester: 38 mm	Glass wool 38 mm	Polyester: 38 mm
Glass		Tempered Low Iron, 3.2mm thick	Tempered Low Iron, 3.2mm thick	Tempered Low Iron, 3.2mm thick	Tempered Low Iron, 3.2mm thick

TYPICAL INSTALLATION – SOLAR THERMOSIPHON 52H180

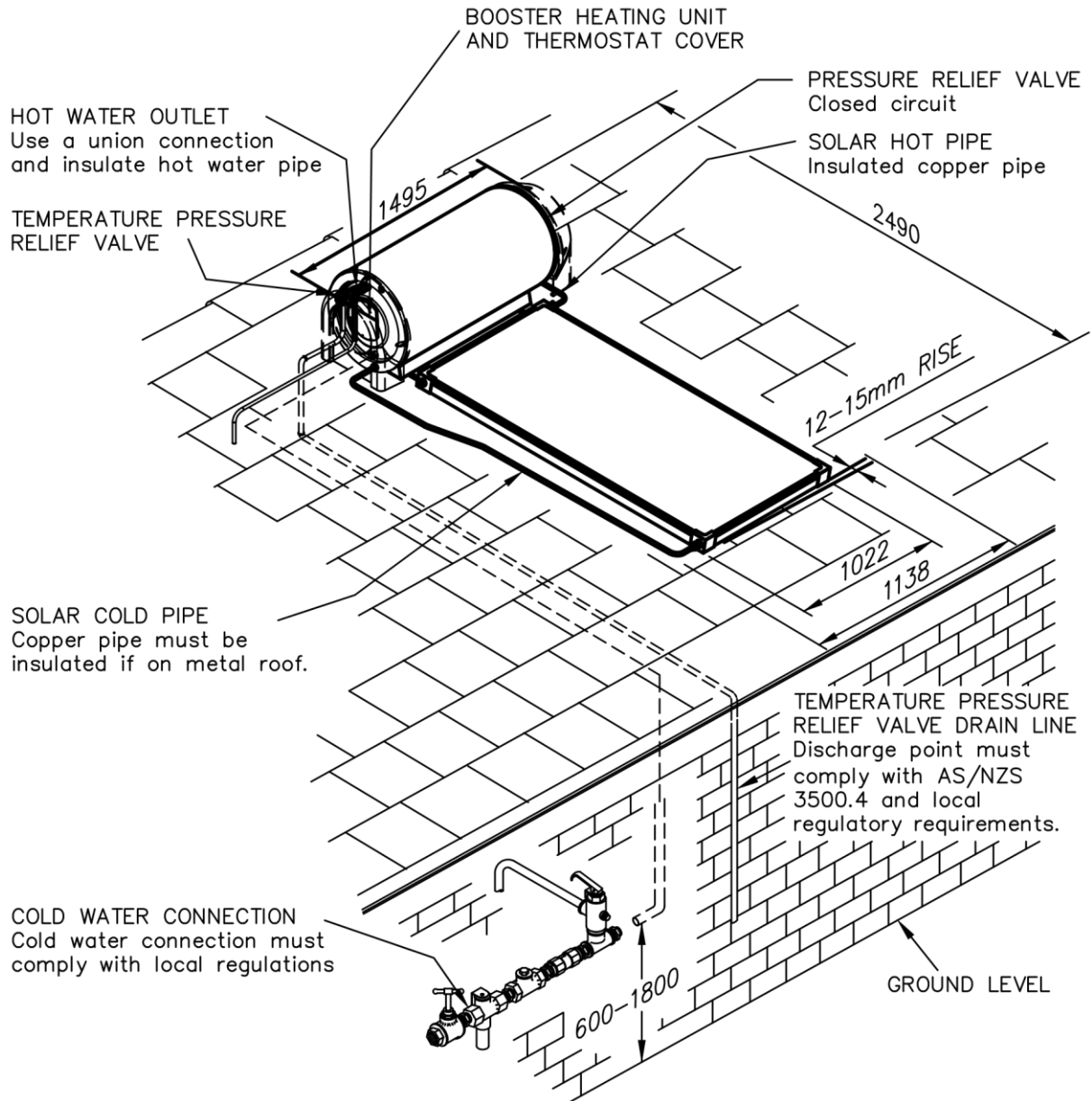

52H180/1L shown

TYPICAL INSTALLATION – SOLAR THERMOSIPHON 52H300

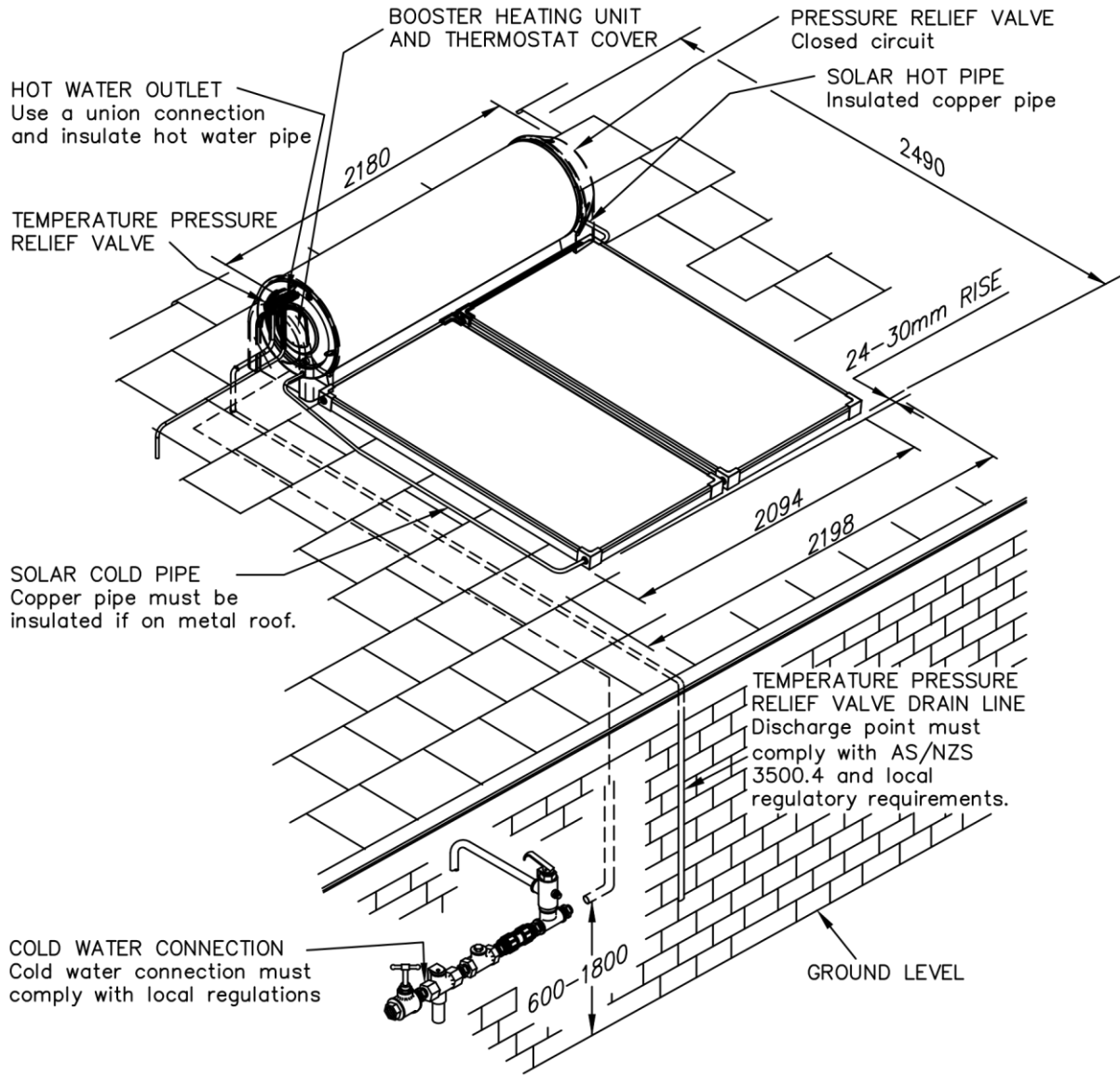

52H300/2L shown

ASSEMBLY DIAGRAM – 52L SERIES – SCREWED FITTING NPT200, L COLLECTORS

Components

- | | | |
|--|---|--|
| 1. Solar Hot Pipe | 13. Collector Rail | 23. Adaptor Union M33 M x G 3/4 F Conetite |
| 2. A - TPR Valve HTT55-1 – 850 kPa | 14. Tank Strap | 24. Plastic End Cover (pr) *** |
| 2. B - Insulation kit TPRV | 15. A - Solar Cold Pipe | 28. Thermosiphon Restrictor Valve (TRV) - conetite |
| 3. Bush Reducing R 3/4 M x Rp 1/2 F | 15. B – Solar Cold Pipe Upper with TRV | 36. Tank to Collector Spacer |
| 4. M33 Gland Nut | 15. C – Solar Cold Pipe Lower with TRV | 37. Union R 3/4 M x G 3/4 M Conetite |
| 5. Collector Union – screwed fittings | 16. Combination Isolation, Strainer & Non-Return Valve ** | 38. Collector Strap |
| 6. Copper Blanking Disk | 17. PLV 500 kPa* | |
| 7. O-ring 25 ID x 3.2 mm | 18. Olive Compression 1/2" | * if required – not supplied |
| 8. ECV H50 – 700 kPa | 19. Nut Compression G1/2" | ** required – not supplied |
| 9. Brass Nipple R1/2M x R1/2M ** | | *** optional |
| 10. Brass Tee G1/2M x G1/2M x G1/2M ** | | |
| 11. Collector Clamp & Fasteners | | |
| 12. Union R1/2M x G1/2M Olive ** | | |

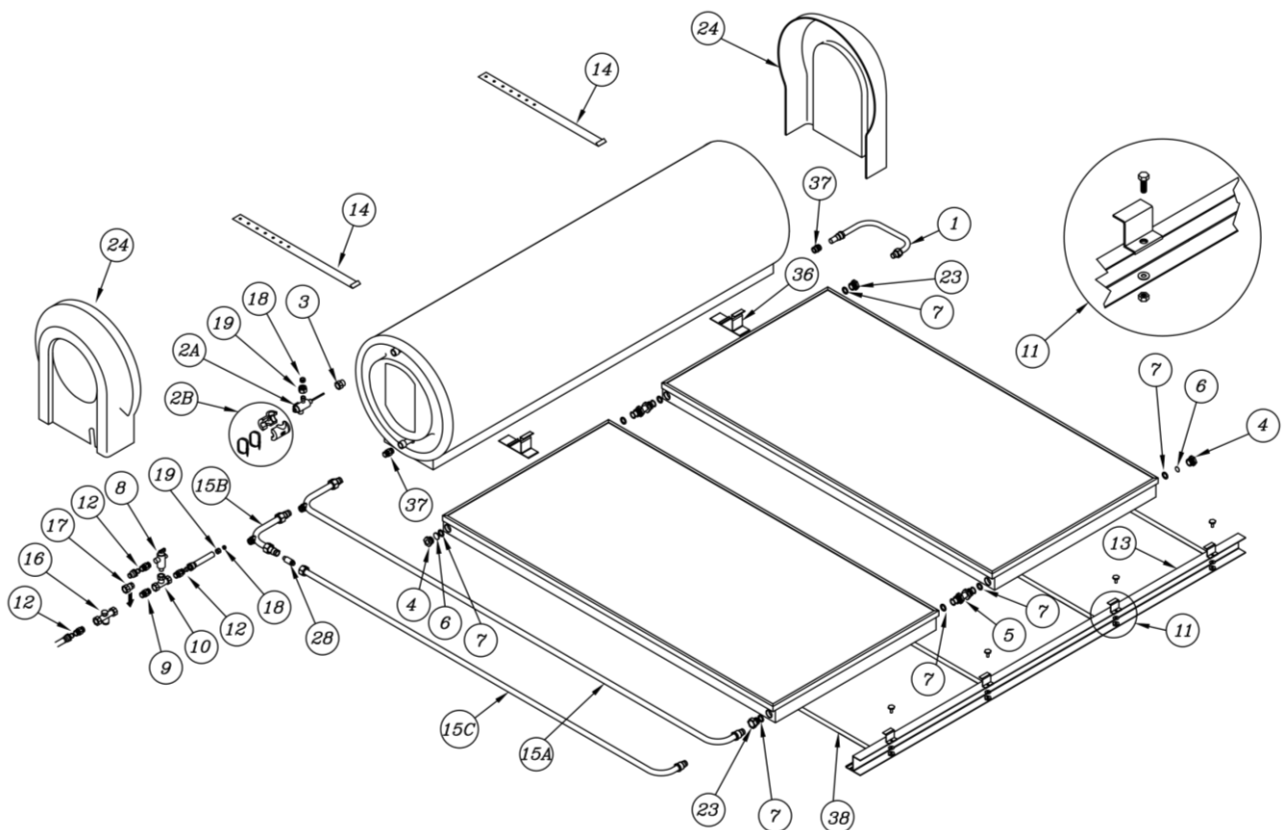

Refer to “System Components and Kit Contents – 52L180, 2L300 Systems – NPT200 and L Collectors with Screwed Fittings” on page 43 for the list of components supplied in the parts kits for the systems below.

- | | |
|----------|---|
| 12105500 | 52L180 tank with one NPT200 or L solar collector – without TRV |
| 12105501 | 52L180 tank with one NPT200 or L solar collector – with TRV |
| 12105502 | 52L300 tank with two NPT200 or L solar collectors – without TRV |
| 12105503 | 52L300 tank with two NPT200 or L solar collectors – with TRV |

Refer to the installation instructions supplied with the installation parts kits below for the list of components supplied in the parts kits, an exploded view assembly diagram and assembly instructions.

For Australian and non-Australian markets

- | | |
|----------|--|
| 12103101 | 52L180 tank with one CSA2007 Envelope solar collector – with TRV |
| 12103103 | 52L300 tank with two CSA2007 Envelope solar collectors – with TRV |

For non-Australian markets

- | | |
|----------|---|
| 12103120 | 52L180 tank with one CSA2007 Envelope solar collector – without TRV |
| 12103121 | 52L300 tank with two CSA2007 Envelope solar collectors – without TRV |

ASSEMBLY DIAGRAM – 52H SERIES WITHOUT OTP – SCREWED FITTING NPT200, L COLLECTORS

Components

- | | | |
|---|---|--|
| 1. Solar Hot Pipe | 12. Union R1/2M x G1/2M Olive ** | 22. Caleffi Pressure Relief Valve 200 kPa |
| 2. A –TPR Valve HTT55-1 – 850 kPa | 13. Collector Rail | 23. Adaptor Union M33 M x G 3/4 F Conetite |
| 2. B – Insulation kit TPRV | 14. Tank Strap | 24. Plastic End Cover (pr) *** |
| 3. Bush Reducing R ¾ M x Rp ½ F | 15. Solar Cold Pipe | 25. Label Fill / Drain |
| 4. M33 Gland Nut | 16. Combination Isolation, Strainer & Non-Return Valve ** | 32. Copper Blanking Disk |
| 5. Collector Union - screwed | 17. PLV 500 kPa * | 36. Tank to Collector Spacer |
| 6. Spring Clip for Caleffi Relief Valve | 18. Olive Compression 1/2" | 37. Union R ¾ M x DN15 Olive |
| 7. O-ring 25 ID x 3.2 mm | 19. Nut Compression G1/2" | 38. Collector Strap |
| 8. ECV H50 – 700 kPa | 20. Fill / Drain Valve | * if required – not supplied |
| 9. Brass Nipple R1/2M x R1/2M ** | | ** required – not supplied |
| 10. Brass Tee G1/2M x G1/2M x G1/2M ** | | *** optional |
| 11. Collector Clamp & Fasteners | | |

Note: Item 22 (Part No 220307 - Valve Pressure Relief ½" Caleffi Clip In 312004) and item 6 (Part No 088100 - Spring Clip for Relief Valve Caleffi) are supplied with the solar storage tank behind its end cover.

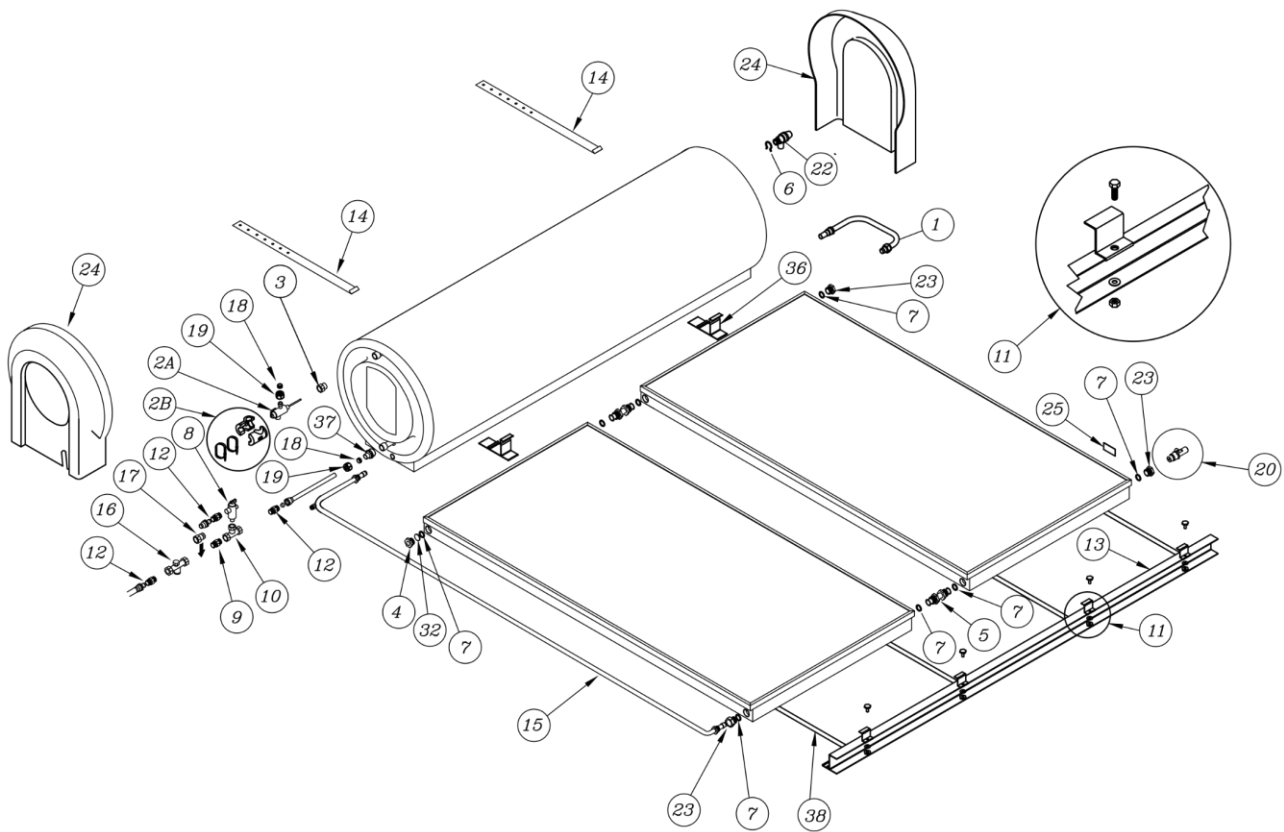

Refer to “System Components and Kit Contents – 52H180, 52H300 Systems – NPT200 and L Collectors with Screwed Fittings” on page 44 for the list of components supplied in the parts kits for the systems below.

- | | |
|----------|---|
| 12105520 | 52H180 tank with one NPT200 or L solar collector – without OTP |
| 12105522 | 52H300 tank with two NPT200 or L solar collectors – without OTP |
| 12105524 | 52H300 tank with three NPT200 or L solar collectors – without OTP |

Refer to the installation instructions supplied with the installation parts kits below for the list of components supplied in the parts kits, exploded view assembly diagrams and assembly instructions.

For Australian and non-Australian markets

- | | |
|----------|--|
| 12103110 | 52H180 tank with one CSA2007 or SPA2000 Envelope solar collector – without OTP |
| 12103112 | 52H300 tank with two SPA2000 Envelope solar collectors – without OTP |

For non-Australian markets

- | | |
|----------|---|
| 12103130 | 52H180 tank with one CSA2007 or SPA2000 Envelope solar collector – without OTP |
| 12103131 | 52H300 tank with two CSA2007 or SPA2000 Envelope solar collectors – without OTP |

ASSEMBLY DIAGRAM – 52H SERIES WITH OTP – SCREWED FITTING NPT200, L COLLECTORS

Components

- | | | |
|---|---|---------------------------------------|
| 1. Solar Hot Pipe | 16. Combination Isolation, Strainer & Non-Return Valve ** | 30. Tank to OTP Valve Pipe |
| 2. A – TPR Valve HTT55-1 – 850 kPa | | 31. OTP Valve |
| 2. B – Insulation kit TPRV | 17. PLV 500 kPa * | 32. Copper Blanking Disk |
| 3. Bush Reducing R ¾ M x Rp ½ F | 18. Olive Compression 1/2" | 33. Plug G 1/8 M and 'O' Ring |
| 4. M33 Gland Nut | 19. Nut Compression G1/2" | 34. Adaptor G 1/8" Nipple |
| 5. Collector Union - screwed | 20. Fill / Drain Valve | 35. Adaptor clip in port and 'O' Ring |
| 6. Spring Clip for Caleffi Relief Valve | 22. Caleffi Pressure Relief Valve 200 kPa | 36. Tank to Collector Spacer |
| 7. O-ring 25 ID x 3.2 mm | 23. Adaptor Union M33 M x G ¾ F Conetite | 37. Union R ¾ M x DN15 Olive |
| 8. H50 ECV 700 kPa | 24. Plastic End Cover (pr) *** | 38. Collector Strap |
| 9. Brass Nipple R1/2M x R1/2M ** | 25. Label Fill / Drain | 39. OTP Expansion Reservoir Tank |
| 10. Brass Tee G1/2M x G1/2M x G1/2M ** | 26. Reservoir Tank Clamp | |
| 11. Collector Clamp & Fasteners | 27. Clamp Mounting Bracket | * if required – not supplied |
| 12. Union R1/2M x G1/2M Olive ** | 28. Tek Screw 10g-16 x 25mm | ** required – not supplied |
| 13. Collector Rail | 29. Flexi Hose 3/8 BSP F | *** optional |
| 14. Tank Strap | | |
| 15. Solar Cold Pipe | | |

Note: Item 22 (Part No 220307 - Valve Pressure Relief ½" Caleffi Clip In 312004) and item 6 (Part No 088100 - Spring Clip for Relief Valve Caleffi) are supplied with the solar storage tank behind its end cover.

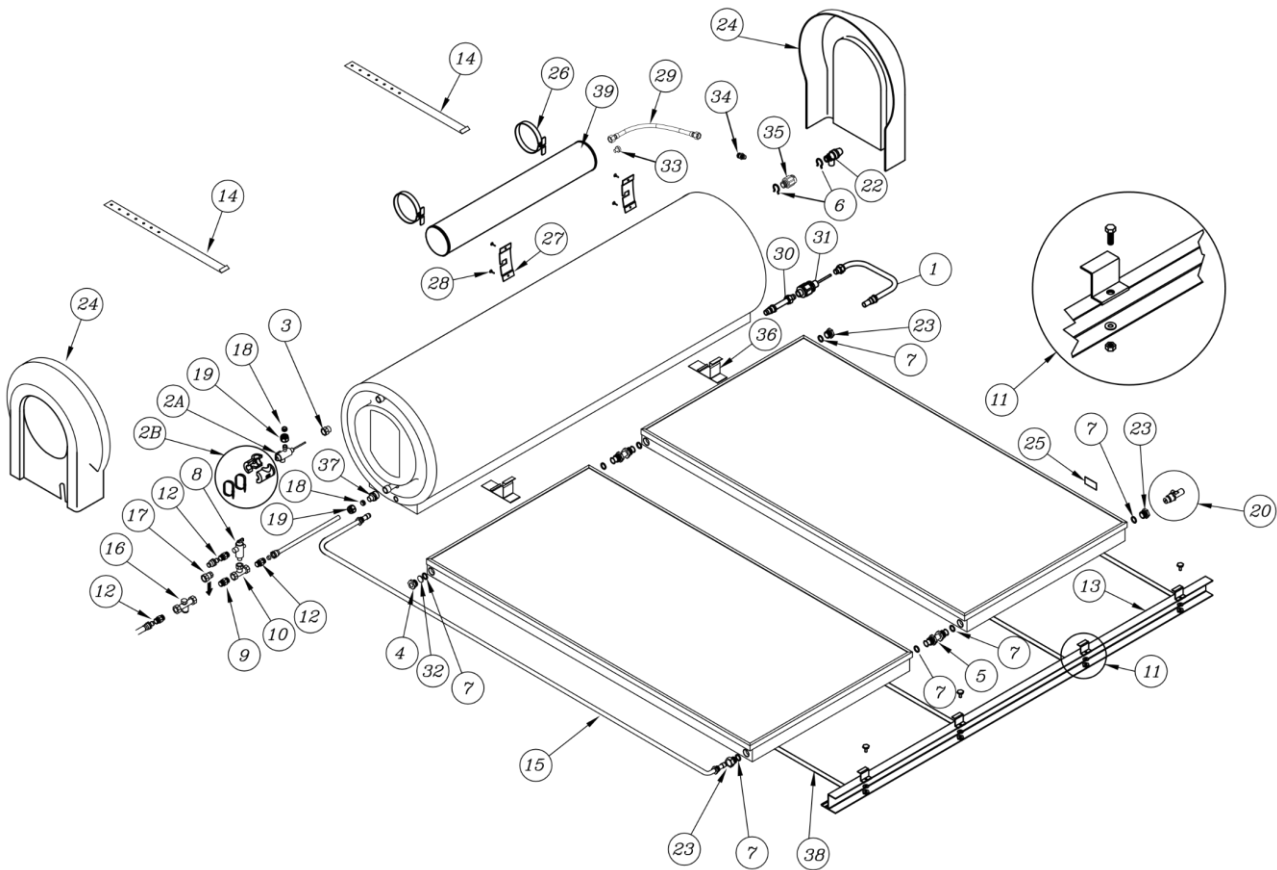

Refer to **"System Components and Kit Contents – 52H180, 52H300 Systems – NPT200 and L Collectors with Screwed Fittings"** on page 44 for the list of components supplied in the parts kits for the systems below.

- | | |
|----------|--|
| 12105523 | 52H300 tank with two NPT200 or L solar collectors – with OTP |
| 12105525 | 52H300 tank with three NPT200 or L solar collectors – with OTP |

Refer to the installation instructions supplied with the installation parts kits below for the list of components supplied in the parts kits, exploded view assembly diagrams and assembly instructions.

For Australian and non-Australian markets

- | | |
|----------|--|
| 12103113 | 52H300 tank with two CSA2007 or SPA2000 Envelope solar collectors – with OTP |
| 12103115 | 52H300 tank with three CSA2007 or SPA2000 Envelope solar collectors – with OTP |

INSTALLATION – SOLAR COLLECTORS

SOLAR COLLECTOR LOCATION

The solar collectors must be installed in a shade free position. The surrounds should be checked for higher buildings or trees which may cause shade at other times of the year and for small trees which may grow and shade the solar collectors in the future.

The installation must comply with the requirements of AS/NZS 3500.4 and all local codes and regulatory authority requirements.

Refer to “[System Assembly](#)” on page 43 for the procedure to mount the system and connection details of the solar hot and solar cold pipes.

ROOF STRENGTH

The water heater must be installed on an adequately supported area of roof. The installer must ensure the structural integrity of the building is not compromised by the solar water heater installation and the roof structure is suitable to carry the full weight of the solar storage tank, solar collectors and frame (if one is installed). If in any doubt of the construction or the condition of the roof, the roof should be suitably strengthened. Consult a structural engineer.

The solar storage tanks, when full of water, weigh approximately 377 kg (300 litre) and 231 kg (180 litre). Each SPA2000 solar collector and its fittings weighs up to approximately 55 kg when full of closed circuit fluid and each NPT200 and CSA2007 solar collector and its fittings weighs up to approximately 44 kg when full of fluid.

ROOF AREA FOR INSTALLATION

The roof area required for the solar storage tank and solar collectors is (excluding service and access space):

180 litre x 1 collector	–	1.6 m wide x 2.5 m deep.	Weight (full) up to 287 kg approx.
300 litre x 2 collectors	–	2.5 m wide x 2.5 m deep.	Weight (full) up to 484 kg approx.
300 litre x 3 collectors	–	3.5 m wide x 2.5 m deep.	Weight (full) up to 507 kg approx.

Sufficient space should be left around the thermosiphon solar water heater to allow for safe service access. A minimum of one (1) metre clearance is recommended to be left around the solar storage tank and solar collectors on the other three sides for safe service access.

ORIENTATION OF SOLAR COLLECTORS

The optimum orientation of solar collectors, to maximise system performance, is facing true north (in the southern hemisphere) or true south (in the northern hemisphere). However, the optimum orientation of solar collectors is not always practical or achievable. If it is not possible to achieve the optimum orientation, then it is recommended to install the solar collectors as close to the optimum orientation as possible.

Solar collectors may be installed up to 90° from the optimum orientation, however solar system performance will be reduced. The total solar radiation received by solar collectors will reduce by approximately 4% to 5% when facing 45° from the optimum orientation and approximately 10% to 15% when facing 90° from the optimum orientation. The system owner needs to be made aware of, understand and accept that solar system performance will be reduced and increased boosting may be required to meet their hot water requirements if the system is installed away from the optimum orientation.

Where the orientation is greater than 60° from the optimum and depending upon the type of system to be installed and the geographic location of the installation, selective surface collectors in lieu of non-selective surface collectors may be able to be installed to make up for the reduction in solar performance. On a 300 litre closed circuit system an additional solar collector may also be installed. Note, these options may not be required in either warmer latitudes or lower hot water load applications where sufficient solar performance can still be achieved, or where over-performance of such a system is likely or has proven to occur.

Refer to “[Solar Collectors](#)” on page 25 for additional information on the selection of solar collectors for this system.

Each of these options should be discussed with the system owner. If neither of these options is possible nor suitable, nor acceptable to the system owner, then the system owner needs to be made aware of, understand and accept that increased boosting may be required to meet their hot water requirements.

Where the collectors may be installed at a similar angle either east or west of the optimal orientation, then the hot water load and usage pattern may need to be considered. If the majority of hot water usage is before 2:00 PM favour an easterly bias. If the majority of hot water usage is after 2:00 PM favour a westerly bias.

Note: Always check for true north or true south using a compass or other suitable device.

INCLINATION OF SOLAR COLLECTORS

To help maximise system performance, solar collectors should be installed with an optimum inclination. This is equal to 90% to 100% of the local latitude angle when collectors are oriented within 60° of true north or true south, and between 10° and 20° when the collectors are oriented between 60° and 90° from the optimum orientation.

Generally, improved summer performance is obtained from an angle of inclination less than the optimum angle and improved winter performance is obtained by an angle of inclination greater than the optimum angle. If the angle of inclination varies by 20° from the optimum angle, the solar collectors will receive about 10% less total annual solar radiation. The [latitude of some Australian cities](#) are listed on page 41.

AS/NZS 3500.4 states that solar collectors shall be installed at an angle within 20° of the local latitude angle.

However, the optimum inclination of solar collectors is not always practical or achievable. A thermosiphon solar water heater may be installed at the roof angle for simplicity of installation and appearance, but must never be less than 10° from the horizontal.

The water heater is suitable for installations with an inclination of up to 30°. Where the solar water heater is installed at inclinations greater than 30°, a With Pitch frame and tank frame mounting kit are necessary. Refer to your local Solar Distributor for details.

A Variable-Pitch frame can be installed to increase the angle of inclination of the thermosiphon solar water heater. This type of frame should be used if the roof pitch is less than 10° or varies by more than 20° below the optimum angle. A tank frame mounting kit is also required with a Fixed Pitch frame. Refer to your local Solar Distributor for details.

The use of a Variable-Pitch frame should be discussed with the system owner. If this option is neither possible nor acceptable to the system owner, then the system owner needs to be made aware of, understand and accept that increased boosting may be required to meet their hot water requirements.

CYCLONIC OR HIGH WIND AREAS

For an installation of a thermosiphon solar water heater in a cyclonic or high wind area, a suitable frame and a tank frame mounting kit are required. Refer to your local Solar Distributor for details.

LATITUDE OF SOME AUSTRALIAN CITIES

Adelaide	35°S	Cairns	17°S	Hobart	42°S	Port Hedland	20°S
Alice Springs	24°S	Canberra	35°S	Mildura	34°S	Rockhampton	24°S
Brisbane	27°S	Darwin	12°S	Melbourne	38°S	Sydney	34°S
Broken Hill	31°S	Geraldton	28°S	Perth	32°S	Townsville	19°S



WARNING: Plumber – Be Aware

- The solar hot and solar cold pipe work between the thermosiphon solar storage tank and the solar collectors are supplied in the parts kit. The supplied copper solar hot and solar cold pipes **MUST BE** used.
- If the solar water heater is installed either on a metal roof or in a trafficable area, such as on an accessible roof, then the solar hot and solar cold pipes must be insulated. The solar hot and solar cold pipes may be required to be insulated to comply with local regulations.

If insulation is required, the full length of the solar hot and solar cold pipes **MUST BE** insulated.

The insulation must:

- be of a closed cell type or equivalent, suitable for a solar water heating application and capable of withstanding the temperature of the water or closed circuit fluid generated by the solar collectors under stagnation conditions

The specification of the chosen insulation material should be checked with the insulation manufacturer prior to installation as different materials may vary in temperature tolerance.

- be at least 13 mm thick
- be weatherproof and UV resistant
- be fitted up to and cover the connections on both the solar storage tank and the solar collectors.

The insulation will offer protection to a metal roof against corrosion due to water running off the copper pipes, assist in avoiding accidental contact with the solar pipe work as very high temperature water or closed circuit fluid can flow from the solar collectors to the solar storage tank, and also reduce pipe heat losses.

- Plastic pipe **MUST NOT** be used, as it will not withstand the high temperature and pressure of the closed circuit fluid (closed circuit system) and water (open circuit system) generated by the solar collectors under stagnation conditions. Failure of plastic pipe can lead to the release of high temperature closed circuit fluid and water and cause severe water damage and flooding.
- There **must be a continuous fall of a minimum 10°** in the pipe work from the thermosiphon solar storage tank to the solar collectors. The highest point of the solar cold pipe and solar hot pipe must be where they connect to the thermosiphon solar storage tank, otherwise thermosiphoning will not occur.
- The solar water heater is to be isolated during the testing and commissioning of the heated water reticulation system in a building, in accordance with Clause 9.3 (a) of AS/NZS 3500.4:2021.

SYSTEM ASSEMBLY

COMPONENTS AND KIT CONTENTS

The thermosiphon solar water heater is supplied with a parts kit, which contains the components required to assemble the solar storage tank and solar collectors together.

System Components and Kit Contents – 52L180, 52L300 Open Circuit Systems NPT200 and L Collectors with Screwed Fittings

12105500	52L180 tank with one NPT200 or L solar collector – without TRV
12105501	52L180 tank with one NPT200 or L solar collector – with TRV
12105502	52L300 tank with two NPT200 or L solar collectors – without TRV
12105503	52L300 tank with two NPT200 or L solar collectors – with TRV

Item	Part No	Kit Components and Description	1210 5500	1210 5501	1210 5502	1210 5503
1 *	341680	Pipe hot assembly 52L180 DN20	1 *	1 *	-	-
1 *	341681	Pipe hot assembly 52L300 DN20	-	-	1 *	1 *
2A *	AQ0262014	Valve TPR ½" HTT55-1 850 kPa 5" probe	1 *	1 *	1 *	1 *
2B	345094	Insulator Valve TPR HTT55-1	1	1	1	1
3	337280	Bush Reducing R3/4 M x RP1/2 F	1	1	1	1
4	330600	Gland nut M33 M	2	2	2	2
5	330695	Collector union screwed fittings	-	-	2	2
6	330606	Copper blanking disc	3	3	3	3
7	330171	O-ring 25 ID x 3.2 mm	5	5	10	10
8	339210	Valve ECV ½" H50 700 kPa	1	1	1	1
9	-	Nipple R1/2 M x R1/2 M	to be supplied by installer			
10	-	Tee G1/2 F x G1/2 F x G1/2 F	to be supplied by installer			
11	331928	Collector clamp	2	2	4	4
11	209130	Screw M8 SS	2	2	4	4
11	209124	Washer Flat 8 x 16 x 1.6 mm SS A2 304	2	2	4	4
11	209118	Nut M8 x 1.25 SS G304 A2-70	2	2	4	4
12	-	Union Body R1/2 M x G1/2 M Olive	to be supplied by installer			
13	331847	Collector mounting rail 1020mm long standard	1	1	-	-
13	331846	Collector mounting rail 1650mm long standard	-	-	1	1
14	343064	Tank strap	2	2	2	2
15A	341682	Pipe cold assembly 52L180 DN20	1	-	-	-
15A	331683	Pipe cold assembly 52L300 DN20	-	-	1	-
15B	341686	Pipe cold assembly upper DN20 TRV	-	1	-	1
15C	341685	Pipe cold assembly lower 52L180 DN20 TRV	-	1	-	-
15C	341687	Pipe cold assembly lower 52L300 DN20 TRV	-	-	-	1
16	-	Valve Isolation, Non-return, Line Strainer	to be supplied by installer			
17	-	Pressure Limiting Valve (if required)	to be supplied by installer			
18	331656	Olive ½"	2	2	2	2
19	331655	Nut compression G½	2	2	2	2
23	344297	Adaptor union body M33 M x G 3/4 F conetite	2	2	2	2
24	290206	Black End Covers – set of 2 supplied separately	1	1	1	1
28	344395	Valve thermosiphon resistor - Conetite	-	1	-	1
36	337144	Tank to collector spacer	2	2	2	2
37	344298	Union Body R 3/4 M x G 3/4 M Cone	2	2	2	2
38	204600	Collector strap	2	2	2	2

* **Note:** Item 1 (Part No 341680 - Hot Pipe Assy 52L180 and Part No 341681 - Hot Pipe Assy 52L300) and Item 2A (Part No AQ0262014 TPR Valve) are supplied with the solar storage tank inside the bottom end of the tank carton, and not in the parts kits. This applies to tanks manufactured from October 2023.

**System Components and Kit Contents – 52H180, 52H300 Closed Circuit Systems
NPT200 and L Collectors with Screwed Fittings**

12105520	52H180 tank with one NPT200 or L solar collector – without OTP
12105522	52H300 tank with two NPT200 or L solar collectors – without OTP
12105523	52H300 tank with two NPT200 or L solar collectors – with OTP
12105524	52H300 tank with three NPT200 or L solar collectors – without OTP
12105525	52H300 tank with three NPT200 or L solar collectors – with OTP

Item	Part No	Kit Components and Description	1210 5520	1210 5522	1210 5523	1210 5524	1210 5525
1	344451	Pipe hot assembly 52H180	1	-	-	-	-
1	344453	Pipe hot assembly 52H300 2 collector	-	1	-	1	-
1	344586	Pipe hot assembly 52H300 2 collector OTP	-	-	1	-	-
1	344587	Pipe hot assembly 52H300 3 collector OTP	-	-	-	-	1
2A *	AQ0262014	Valve TPR ½" HTT55-1 850 kPa 5" probe	1 *	1 *	1 *	1 *	1 *
2B	345094	Insulator Valve TPR HTT55-1	1	1	1	1	1
3	337280	Bush Reducing R3/4 M x RP1/2 F	1	1	1	1	1
4	330600	Gland nut M33 M	1	1	1	1	1
5	330695	Collector union screwed fittings	-	2	2	4	4
6 *	088100	Spring clip for Relief Valve Caleffi	1 *	1 *	2 *	1 *	2 *
7	330171	O-ring 25 ID x 3.2 mm	5	10	10	15	15
8	339210	Valve ECV ½" H50 700 kPa	1	1	1	1	1
9	-	Nipple R1/2 M x R1/2 M	to be supplied by installer				
10	-	Tee G1/2 F x G1/2 F x G1/2 F	to be supplied by installer				
11	331928	Collector clamp	2	4	4	6	6
11	209130	Screw M8 SS	2	4	4	6	6
11	209124	Washer Flat 8 x 16 x 1.6 mm SS A2 304	2	4	4	6	6
11	209118	Nut M8 x 1.25 SS G304 A2-70	2	4	4	6	6
12	-	Union Body R1/2 M x G1/2 M Olive	to be supplied by installer				
13	331847	Collector mounting rail 1020 mm long standard	1	-	-	1	1
13	331846	Collector mounting rail 1650mm long standard	-	1	1	1	1
14	343064	Tank strap	2	2	2	2	2
15	344450	Pipe cold assembly 52H180	1	-	-	-	-
15	344452	Pipe cold assembly 52H300	-	1	1	1	1
16	-	Valve Isolation, Non-return, Line Strainer	to be supplied by installer				
17	-	Pressure Limiting Valve (if required)	to be supplied by installer				
18	331656	Olive ½	2	2	2	2	2
19	331655	Nut Compression G1/2	2	2	2	2	2
20	220376	Fill plug assembly ¾" conetite including gland nut	1	1	1	1	1
22 *	220307	Valve Pressure Relief ½" Caleffi Clip In 312004	1 *	1 *	1 *	1 *	1 *
23	344297	Adaptor union body M33 M x G3/4F conetite	3	3	3	3	3
24	290206	Black End Covers – set of 2 supplied separately	1	1	1	1	1
25	347189	Label fill / drain	1	1	1	1	1
26	343037	Reservoir tank SS clamp assembly	-	-	2	-	3
27	344399	Mounting bracket aluminium (with adhesive tape)	-	-	2	-	3
28	348085	Screw TEK 10G – 16 TPI x 25	-	-	4	-	6
29	344327	Flexi hose 3/8 BSP F x 3/8 BSP F x 400	-	-	1	-	1

Item	Part No	Kit Components and Description	1210 5520	1210 5522	1210 5523	1210 5524	1210 5525
30	344573	Connector assembly tank to OTP valve	-	-	1	-	1
31	209000	Valve OTP thermosiphon arrester TA705 ¾	-	-	1	-	1
32	330606	Copper blanking disc	2	2	2	2	2
33	341515	Plug thumb G1/8 M & O-ring assembly	-	-	1	-	1
34	344593	Adaptor G3/8" x BSP to ISO7 R1/4"	-	-	1	-	1
35	341504	Adaptor Tee clip in port to ISO7 RP¼ & O-ring	-	-	1	-	1
36	337144	Tank to collector spacer	2	2	2	3	3
37	331658	Union Body R ¾ M x G ½ M Olive	1	1	1	1	1
38	204600	Collector strap	2	2	2	3	3
39	344185	Reservoir tank 2 collectors	-	-	1	-	-
39	344186	Reservoir tank 3 collectors	-	-	-	-	1
not shown	331844	Drive cleat	-	-	-	1	1
not shown	337093	Extension pipe assembly systems	-	-	-	2	1
not shown	347187	Instruction to attach fill / drain label	1	1	1	1	1
not shown	347199	Instruction 52H S3 OTP installation	-	-	1	-	1

*** Notes**

Item 2A (Part No AQ0262014 TPR Valve) is supplied with the solar storage tank inside the bottom end of the tank carton, and not in the parts kits. This applies to tanks manufactured from October 2023.

Item 22 (Part No 220307 - Valve Pressure Relief ½" Caleffi Clip In 312004) and one unit of item 6 (Part No 088100 - Spring Clip for Relief Valve Caleffi) are supplied with the solar storage tank, and not in the parts kits.

PREASSEMBLY NOTES

- Pipe work, including that within the roof space, is to be securely fixed to prevent vibration.
- **⚠ Warning:** The tanks and collectors are heavy. Improper lifting techniques could result in personal injury during installation. It is the installer's responsibility to use only approved lifting and safety devices and techniques when lifting collectors and tanks on roofs.
- These solar collectors have passed the AS/NZS 2712 requirements for resistance to hailstone damage, so it is not normally necessary to fit a guard to a collector. Stone Guards are available to provide a level of protection to the collectors against vandalism or accidental damage. Contact Rheem or your local Rheem Solar Water Heater Distributor for details.
- The Rheem warranty **DOES NOT** cover breakage of solar collector glass. Check your insurance policy covers collector glass breakage.

⚠ Warning: No attempt should be made to remove or replace broken collector glass.

The collector glass is not offered as a replacement part. Should the solar collector require replacement, contact Rheem or your local Rheem Solar Water Heater Distributor for details.

- **⚠ Warning:** Do not remove the solar collector packaging completely, prior to the installation as the solar collector surface can become very hot. Remove only sufficient packaging material to enable the installation of the solar collectors.

Upon completion of the installation of the solar water heater the packaging material may be removed from the solar collectors, whether or not the solar water heater is commissioned.

The solar collector packaging must be removed completely prior to the permanent operation of the water heater.

- All connectors, end plugs, O-rings, brass fittings, collector straps, collector angle and temperature pressure relief valve required for the installation are included with the parts kit.

Suitable screws or anchors will be required to fix the collector straps to the rafters for a pitched roof installation.

⚠ Warning: Where roof straps, frames, etc. are secured to roof members, all fixings must be of an appropriate type to suit the type of member. Inadequate or inappropriate fixings may result in the roof straps becoming unsecured and the installation of the solar hot water system becoming unsafe.

- NPT200 and L collectors have screwed fittings. SPA2000 and CSA2007 collectors have conetite fittings.
- All olive compression fittings must use brass or copper olives.
- Use thread sealing tape or an approved thread sealant on all other but the conetite and O-ring fittings.
- If the solar storage tank is being installed with existing solar collectors, then utilise the existing fittings and pipes used on the installation. A new temperature pressure relief valve and expansion control valve must be installed. These valves are not supplied with the tank.
- **Roof Condition:** Check the condition of the roof and advise the client of any broken tiles or damaged roof sheeting before commencing the installation.

- **Notes**

The Assembly Procedure on the following pages is for the installation of systems with either NPT200 or L collectors. It does not cover the installation of the SPA2000 and CSA2007 collectors.

The Assembly Procedure for the systems with either SPA2000 or CSA2007 collectors is contained in the installation instructions supplied in the parts kits for these systems. Please refer to those installation instructions.

ASSEMBLY PROCEDURE

Refer to the assembly diagrams on pages 37 to 39 for the location and position of components.

DO NOT MODIFY THESE PARTS IN ANY WAY.

Refer to the installation instructions supplied with the 52H system OTP kit for additional information of the installation of the over temperature protection components.

1. **Roof Condition:** Check the condition of the roof and advise the client of any broken tiles or damaged roof sheeting before commencing the installation.
2. **Solar Frame:** If a solar frame is to be installed, determine the location of the frame. Refer to “Solar Water Heater Storage Tank Location” on page 27 and “Solar Collector Location” on page 40 and the installation instructions provided with the frame.

Assemble and fix the frame to the roof, following the installation instructions provided with the frame.

Depending upon the positioning of the frame on the roof and any minor fall the roof may have, ensure the collector rail is either horizontal or is higher on the hot outlet side of the solar collectors. If in doubt use a spirit level.

Proceed to Step 7.

3. **Water Heater Location:** If a solar frame is not installed, select a suitable position for the solar water heater.

Refer to “Solar Water Heater Storage Tank Location” on page 27 and “Solar Collector Location” on page 40.

4. **Position of Tank:** Select the position of the solar storage tank so the front of the foot is above a roof batten toward the nose of an even row of tiles or even metal roof sheet. The rear of the foot may be seated over the nose of the tiles on the next row behind. Where possible, the tank should be positioned at least three tiles from the ridge capping to prevent disturbance of the ridge.

5. **Collector Mounting Rail Preparation**

Note: The collector straps are to be fitted to the collector rail before fixing the straps to the rafters.

5.1 If more than two collectors are installed, locate the additional collector rail(s) adjacent to the first collector rail and join together using drive cleat supplied in the parts kit.

5.2 Determine which slots in the collector rail will be used for the collector straps after locating the rafters and taking note of the rafter spacing.

Rafter spacing	Recommended slots	
	One collector (1 x one collector rail)	Two collectors (1 x two collector rail)
300 mm (12")	1, 4 or 2, 3	1, 6 or 2, 5
400 mm (16")	1, 4	1, 5 or 2, 6
450 mm (18")	1, 4	2, 5
500 mm (20")	1, 4	1, 6 or 2, 5
600 mm (24")	2, 3	1, 5 or 2, 6
900 mm (36")	1, 4	2, 5

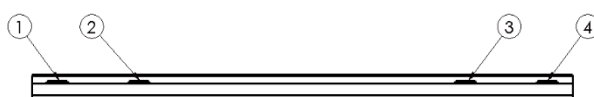

collector rail – one collector

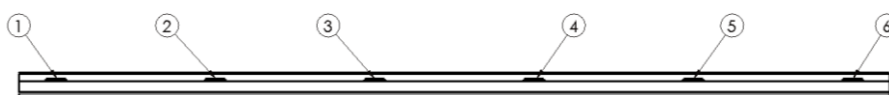

collector rail – two collectors

Rafter spacing	Recommended slots Three collectors (1 x two and 1 x one collector rails)
300 mm (12")	1, 5 (long) & 3 (short)
400 mm (16")	1, 5 (long) & 3 (short)
450 mm (18")	2, 5 (long) & 4 (short)
500 mm (20")	1, 6 (long) & 4 (short)
600 mm (24")	1, 5 (long) & 3 (short)
900 mm (36")	1, 4 (long) & 4 (short)

5.3 Noting the orientation of the collector strap's folded end, slide the long straight end of the collector strap through the appropriate slot from the underside of the collector rail as shown on the left side picture below.

Pull the collector strap through until the first bend in the strap slips into the slot in the collector rail. The strap will engage with the collector rail as shown on the right side picture below.

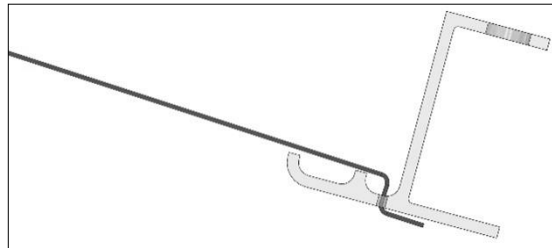
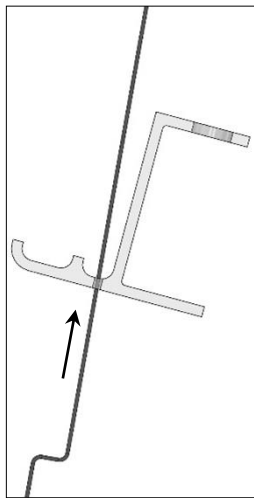

6. **Collector Rail:** Determine the location of the collector rail. Measure down the roof 2070 mm from the position of the foot of the solar storage tank to determine the location of the collector rail.

Note: The solar collectors must be installed at an angle from the horizontal. This is to ensure a sufficient angle rise across the collectors from left to right to assist in optimum thermosiphon operation and solar performance.

Use a spirit level to determine the horizontal. Ensure the end of the collector rail at the hot outlet side of the solar collectors is between:

- 12 – 15 mm (for one solar collector), or
- 24 – 30 mm (for two solar collectors), or
- 36 – 45 mm (for three collectors)

higher up the roof from the horizontal than the left hand end of the collector mounting rail at the inlet side of the solar collectors.

Failure to adhere to this requirement may result in reduced solar performance from the solar water heater.

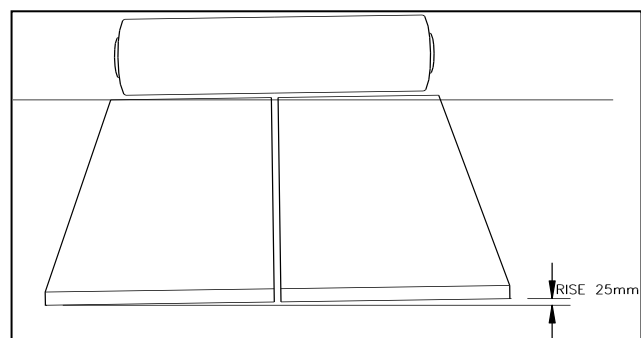
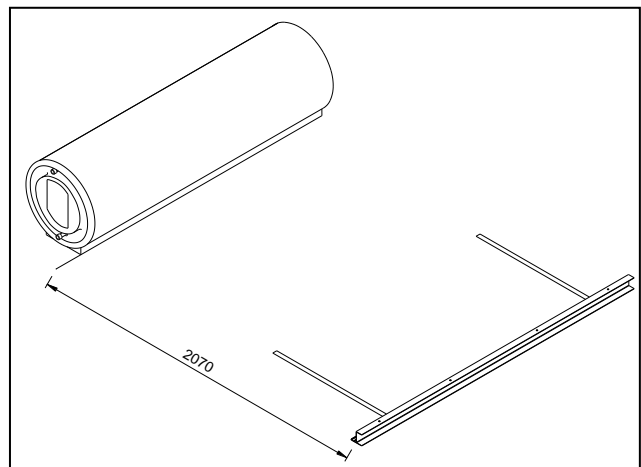

If the roof material is not even where the collectors are to be installed, then it may be necessary to add 10 mm for each collector in the array to the above distances. It is important that the solar hot outlet is the highest point in the collector waterway so the system functions efficiently.

Note: AS/NZS 3500.4 states a minimum of three (3) screws 40 mm long be used per strap. Longer screws or anchors may be required to achieve a 40 mm minimum embedment into rafters for a metal roof. Additional screws or anchors may be required.

Tile Roof: Remove the tiles on the next row above the position of the collector mounting rail to expose the rafters. Ensure the collector mounting rail is at the correct angle from the horizontal. Once in position, fix the collector straps to the rafters, using suitable screws or anchors. Replace the tiles.

Metal Roof: Ensure the collector mounting rail is at the correct angle from the horizontal. Once in position, fix the collector straps to the rafters, through the metal roofing material, using suitable screws or anchors. Care should be taken not to mark Colorbond® or other metal roof sheet with a marking pen and to remove all swarf from the metal roof as these can cause deterioration of the metal roofing material.

Note: Fixings must penetrate only through the high point in the roof material profile.

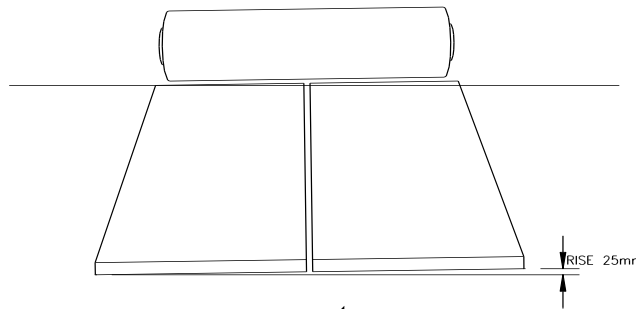

Correct Method of Installing Collectors

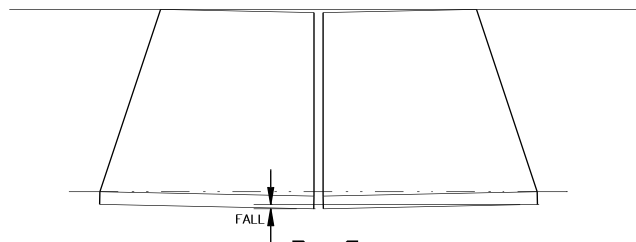

Incorrect Method of Installing Collectors

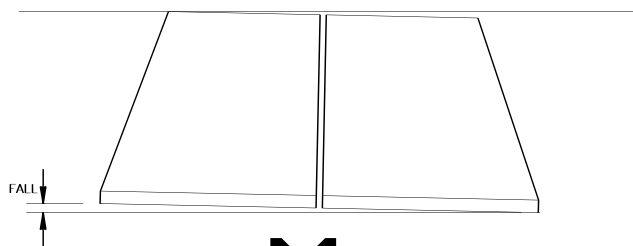

Incorrect Method of Installing Collectors

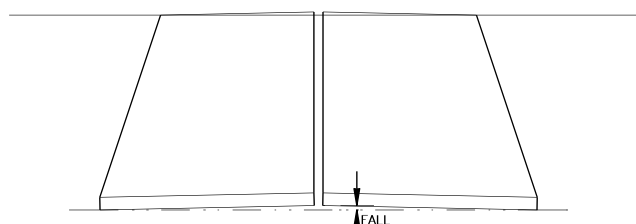

Incorrect Method of Installing Collectors



7. **Solar Collectors:** Using a lifting device, lift the first solar collector onto the roof and place it carefully in the correct configuration with the lower end seated in the collector rail. Prior to positioning the next solar collector (for a two collector installation), firmly clamp (two collector clamps per collector) to the collector rail using the collector clamps, hex screws, washers and nuts provided.

If three collectors are to be installed, it is advisable to place this first collector in the centre of the collector rails.

Repeat this procedure for a second collector, firmly clamping the collector to the collector rail with two clamps, and then a third collectors (if being installed).

For a single collector installation ensure the solar collector is correctly positioned, centred and well seated in the collector rail. Firmly clamp the solar collector (two collector clamps per collector) to the collector rail using the collector clamps, hex screws, washers and nuts provided.

Note: Firmly clamping each solar collector to the collector rail as it is placed in position reduces the possibly of the collectors accidentally moving or sliding off the collector rail.

Remove the red transit plugs from the collector sockets.

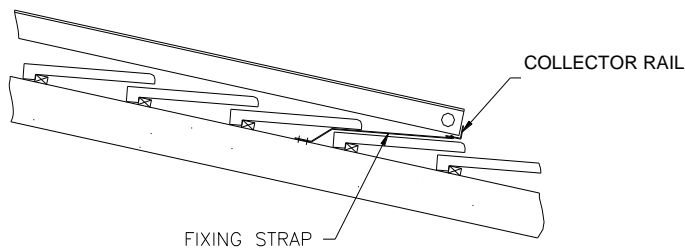

Collector Mounting



O'ring

Note: An NPT200 and L collector have screwed connections. These connections use an O-ring for sealing. The O-rings required are supplied in the parts kit. Identification of the collector type can be found on the label attached on the side of the collector body.

8. **Collector Unions:** For a 300 model with two or three solar collectors, couple the solar collectors together using the M33 collector unions and O-rings (screwed fitting collectors only) supplied in the parts kit.

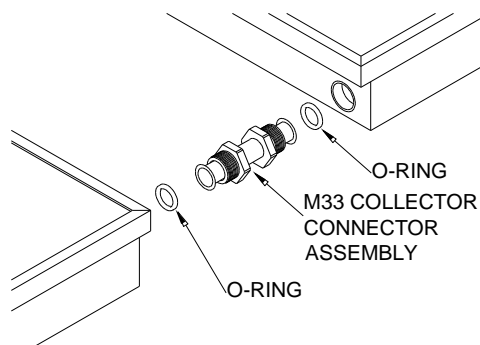

screwed collector connection

Collector Union Assembly

9. **Clamps and Fixing Collector (Bottom):** Ensure the solar collectors are well seated and centred in the collector mounting rail.

Collector Rail: Clamp the solar collectors (two clamps per collector) to the collector mounting rail, using the clamps and hex screws, washers and nuts provided.

Position the collector clamp over the hole in the collector rail with the top lip of the clamp over the collector trim.

Insert the hex screw through the hole in the collector clamp and collector rail, place the washer and nut on the screw and screw the nut until it seats firmly against the lip of the collector rail, applying medium pressure with a spanner to tighten.

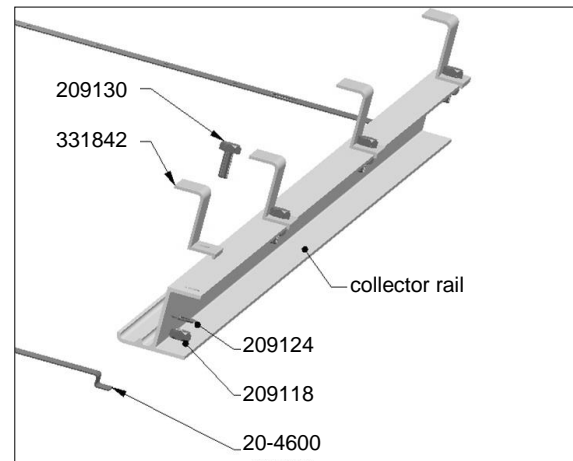

Bottom Collector Rail Collector Clamp Installation

10. **Tank Flashing, Tank to Collector Spacers:**

Tile Roof: If used, fit the tank flashing sheet under the top of the solar collectors and extend up the roof to the top of the solar storage tank location. Lift the roof tiles immediately above the solar storage tank location and secure the flashing sheet to the roofing members. Ensure the flashing sheet makes the section of roof under the tank waterproof.

Metal and Tile Roof: Locate the Tank to Collector spacers (8) against and under the top end of the solar collectors (one per collector for a two collector system). These should be located 200 mm from the sides of the collector for a one collector system or 200 mm from the ends of the tank for a two collector system, and on the top of the tile or metal roof profile.

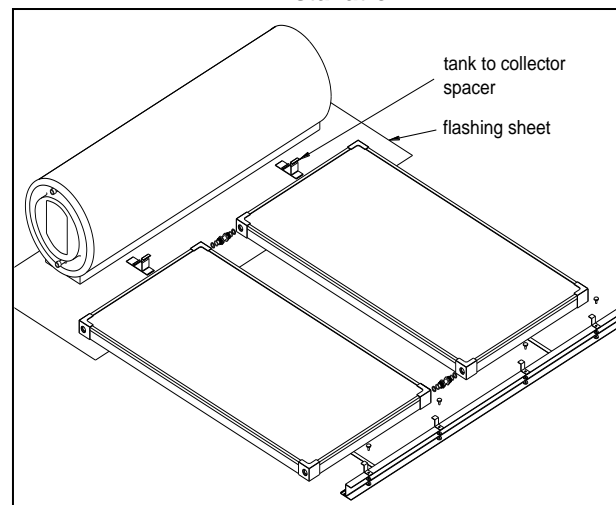

Solar Frame Installation: Ensure the solar collectors are well seated and centred in the tank / collector rail.

11. **Solar Storage Tank Positioning:** Using a lifting device, lift the tank onto the roof. Position the solar storage tank in place above the solar collectors, locating central to the solar collectors before sliding it down onto the Tank to Collector spacers or tank / collector rail if the installation is on a solar frame. Centre the solar storage tank before commencing interconnecting pipe installations.

12. **TRV or OTP System Connection:** If a Thermosiphon Restrictor Valve (TRV) is to be fitted to an 52L system, assemble the cold pipe with the TRV thermostat element pointing towards the tank as per marking. If an Over Temperature Protection (OTP) fitted to an 52H system, refer to the installation instructions supplied with that systems parts kit for additional information of the installation of the over temperature protection components.

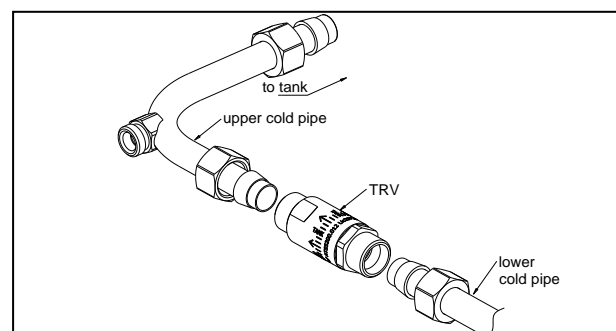

13. **Tank to Collector Connections of Pipe Work:**

52L direct system: Fit a union body R 3/4 M x G 3/4 M with its internal cone profile facing out, into the tank socket inlet on the left hand end of the solar storage tank and one into the tank socket return connection on the right hand end of the solar storage tank.

Fit an adaptor union M33 M x G3/4 F and O'ring, one into collector cold inlet at the bottom left hand side of the first collector and another into the hot outlet at the top right hand side of the second or third collector.

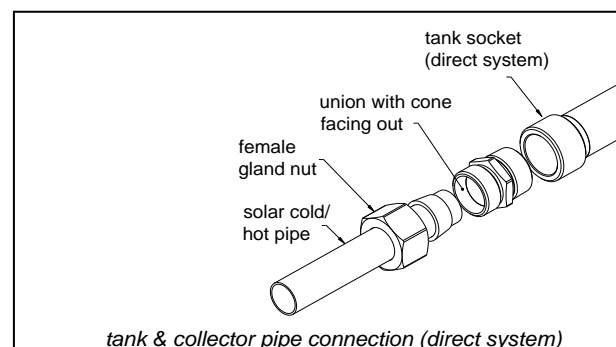

Solar cold pipe: Connect the solar cold pipe to the union on the left hand end of the solar storage tank and collector simultaneously. Ensure the pipe is parallel with the collector. Push the pipe against the tank union stop and hand tighten the gland nut. Hand tighten the gland nut at the collector. Fully tighten both ends of the solar cold pipe.

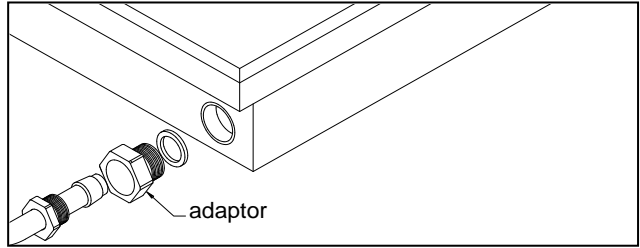

Solar hot pipe: Connect the solar hot pipe to the fitted union body on the right hand end of the solar storage tank and collector simultaneously. Push pipe against the tank union stop and hand tighten the gland nut. Ensure the pipe is parallel with the collector. Hand tighten the gland nut at the collector. Fully tighten both ends of the solar hot pipe.

52H indirect system: The union body R 3/4 M x G 3/4 M to tank socket is not required for the indirect system. Fit an adaptor union M33 M x G3/4 F and O'ring, one into collector cold inlet at the bottom left hand side of the first collector and another into the hot outlet at the top right hand side of the second or third collector.

Solar cold pipe: Connect the solar cold pipe to the heat exchanger connection on the left hand end of the solar storage tank and collector simultaneously. Ensure the pipe is parallel with the collector. Push the pipe against the tank socket sealing face and hand tighten the gland nut. Hand tighten the gland nut at the collector. Fully tighten both ends of the solar cold pipe.

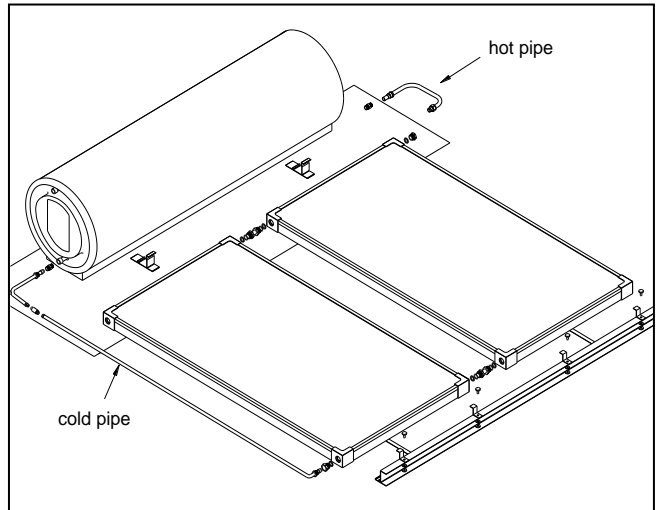

Solar hot pipe: Connect the solar hot pipe to the heat exchanger connection on the right hand end of the solar storage tank and collector simultaneously. Ensure the pipe is parallel with the collector. Push the pipe against the tank socket sealing face and hand tighten the gland nut. Hand tighten the gland nut at the collector. Fully tighten both ends of the solar hot pipe.

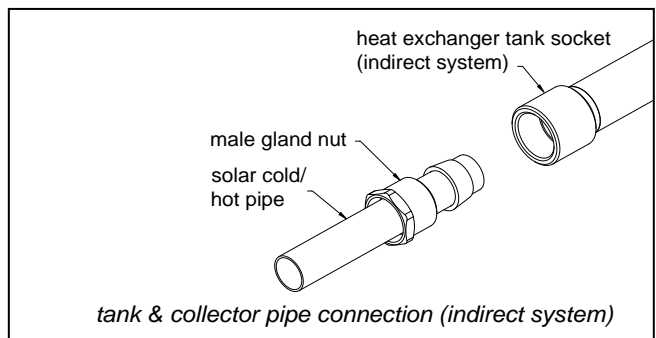

After connecting the tank to collector pipe work, tighten the nuts on the clamps at the collector rail to secure the solar collectors.

14. Fill Drain Valve (Indirect System Only):

52H indirect system collectors: Fit an adaptor union M33 M x G3/4 F and O'ring to the bottom right connection of the solar collectors.

Fit the fill drain valve assembly to the adaptor union.

15. Fill / Drain Label: *52H indirect system:* Attach the Fill / Drain label to the side of the solar collector adjacent to the fill drain valve assembly.

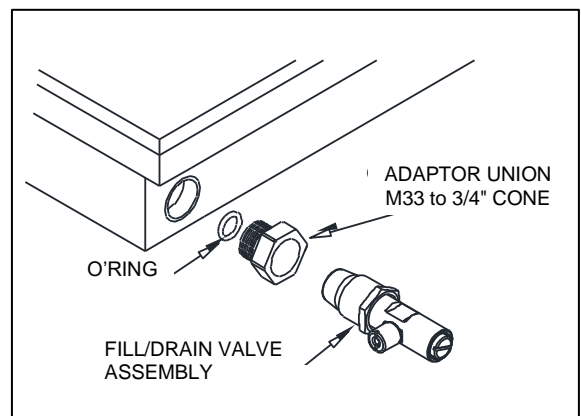

16. End Plugs / Collector Bung:

52L direct and 52H indirect system – NPT200 and L Collector screwed fitting: Fit a blanking disc with an O-ring to the top left connection of the solar collectors and to the bottom right connection of a 52L direct system. Secure in position using an M33 collector nut provided. The blanking disc should be installed with the smooth edge facing into the collector.

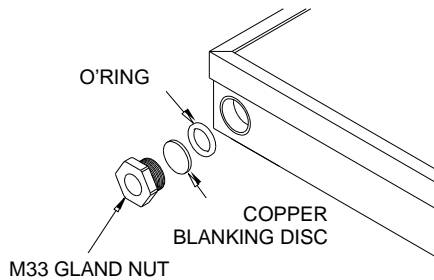

screwed collector connection

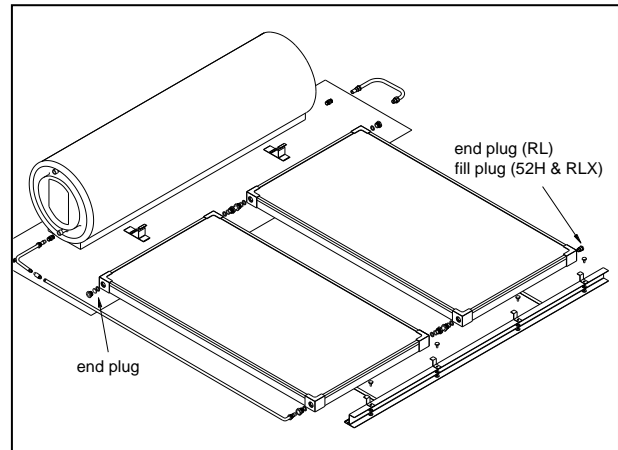

17. **Tank Straps:** On a pitched roof installation, position and hook the tank straps into the louvers at the back and underneath of the tank support foot.

Note: AS/NZS 3500.4 states a minimum of three (3) screws 40 mm long be used per strap. Longer screws or anchors may be required to achieve a 40 mm minimum embedment into rafters for a metal roof. Additional screws or anchors may be required.

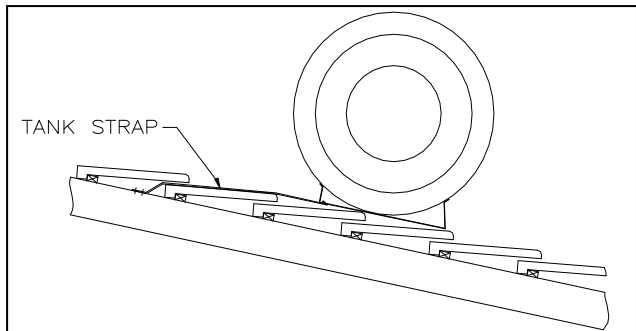

Tile Roof: Remove the tiles on the next row above the position of the solar storage tank to expose the rafters. Once in position, fix the tank straps to the rafters using suitable screws or anchors. Replace the tiles.

Metal Roof: Once in position, fix the tank straps to the rafters, through the metal roofing material, using suitable screws or anchors. The tank straps may be cut to a length of approximately 400 mm to retain the aesthetics of the installation.

Note: Fixings must penetrate only through the high point in the roof material profile.

Refer to ["Installation Check List"](#) on page 55.

18. **Closed Circuit Relief Valve:** *52H indirect system:* Fit the 200 kPa closed circuit pressure relief valve to the top connection on the right hand side of the solar storage tank and secure using the retaining clip provided.

The pressure relief valve and retaining clip are transported behind the end electrical cover at the left hand end of the tank.

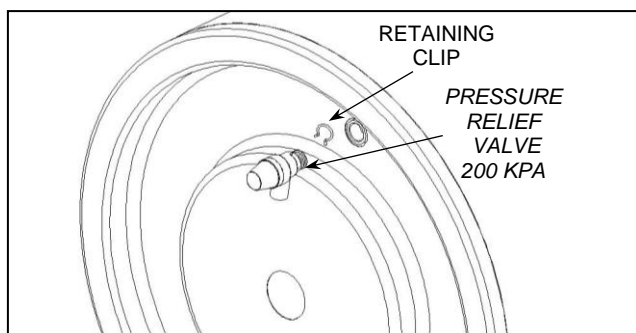

19. **Cold Water Inlet:** *52L direct system:* Connect the copper cold supply pipe to the shoulder of the solar cold pipe using the G $\frac{1}{2}$ compression nut and copper olive provided.

52H indirect system: Fit the Union Body R3/4 M x DN15 Olive provided to the cold water inlet. Connect the copper cold supply pipe using copper olive and compression nut provided.

20. **Hot Water Outlet and Temperature Pressure Relief Valve:** Fit the Reducing Bush (R3/4 M x RP1/2 F) to the hot water outlet.

Screw the temperature pressure relief valve into the Reducing Bush at the hot water outlet.

Orientate the hot outlet of the temperature pressure relief valve toward the rear of the tank and away from the electrical cover. The valve drain connection on the opposite side of the valve will be orientated forwards and must be downward from the horizontal to permit drainage.

The hot water pipe work and drain line from the temperature pressure relief valve **must not** be installed in front of or prevent access to the electrical cover of the water heater.

Connect the copper hot water supply pipe to the temperature pressure relief valve using the G $\frac{1}{2}$ compression nut and copper olive provided.

Refer to “[Relief Valve Drain](#)” on page 59 for the installation requirements of the drain line.

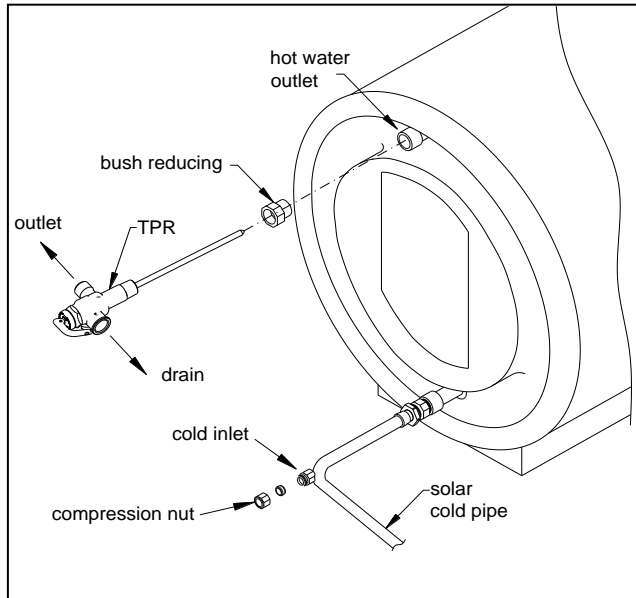

21. **Insulation of the temperature pressure relief valve:** Fit the insulation provided to the TPR valve. Ensure the lever of the TPR valve is accessible after strapping the insulation.
22. **Protective Film:** Peel the protective plastic film from the solar storage tank. The protective plastic will bake on and deteriorate if exposed to sunlight, reducing the aesthetics of the installation and become difficult to remove.
23. **Installation Check List:** Refer to the “[Installation Check List](#)” on page 55 prior to making the plumbing connections and filling the system with water.
24. **Plumbing and Electrical Connections:** Refer to “[Connections – Plumbing](#)” on page 56 for details on the cold water and hot water plumbing and “[Connections – Electrical](#)” on page 60 for details on the electrical connection.

Notes:

- Penetrations through the roofing material must be:
 - at the high point of the roof tile or metal sheet;
 - made neatly and kept as small as practicable;
 - waterproofed upon installation of the hot and cold pipes.
 - Exposed pipe work between the solar storage tank and the penetrations through the roofing material should be kept to a minimum to maintain the aesthetics of the installation.
25. **Closed Circuit Filling:** *52H indirect system:* Refer to “[Closed Circuit Fluid](#)” on page 66 for details on filling the closed circuit with the closed circuit fluid.

Asbestos Roofs

All Occupational Health and Safety matters / procedures must be adhered to in relation to asbestos material. If safety procedures are not adhered to then terminal illness may result from the handling of asbestos.

Care needs to be taken when fixing straps to asbestos roofs. It is suggested that longer Tek screws are used to fit securely into purlins.

Pitch roofs - Greater than 30°

The solar water heater must not be installed on a roof with a pitch greater than 45°.

For installations on a roof with a pitch between 30° and 45°, the water heater is to be installed on a With Pitch frame.

INSTALLATION CHECK LIST

Once the installation is completed and before the tank is full of water and the collector circuit is full of heating fluid, it is IMPORTANT to check the following:

- The solar hot and solar cold pipes grade downwards with a continuous fall of not less than 10° from the solar storage tank to the solar collectors. If in doubt use a spirit level.
- On a pitched roof installation without a frame, the hot outlet side of the collector array is between
 - 12 – 15 mm (for one solar collector), or
 - 24 – 30 mm (for two solar collectors), or
 - 36 – 45 mm (for three solar collectors)

higher up the roof from the horizontal than the solar cold side of the collector array. If in doubt use a spirit level.

- On a frame installation, depending upon the positioning of the frame on the roof and any fall the roof may have, ensure the collector mounting rail is either horizontal or is higher on the hot outlet side of the solar collectors. If in doubt use a spirit level.

CONNECTIONS – PLUMBING

All plumbing work must be carried out by a qualified person and in accordance with the requirements of the Plumbing Code of Australia (PCA) and the Plumbing Standard AS/NZS 3500.4, and all local codes and regulatory authority requirements. In New Zealand, the installation must conform with Clause G12 of the New Zealand Building Code.

Pipe work that is required to enter the house either through a wall, ceiling cavity or roof needs to be fully sealed and weatherproofed and must comply with local building codes and practices.

⚠ Warning: Certain types of plastic pipe, such as polybutylene pipe, are not suitable to be used as a hot water pipe between:

- this water heater and a temperature limiting device, and
- this water heater and a hot water outlet if a temperature limiting device is not installed.

This water heater can produce water at a temperature and pressure which can exceed the performance limits of these types of pipe. This may result in pipe failure leading to severe water damage to the property. If one of these types of plastic pipe is used as a hot water pipe in the property, then a temperature limiting device must be installed between the water heater and this pipe work.

If there is a separate higher temperature hot water line to a non-ablution area or a tempering valve is not required, then a primary temperature control valve can be installed if a 75°C or greater delivery temperature is considered by a consumer to be too high for their needs or the plumbing materials used in the heated water system are not rated to carry 75°C or higher water temperature.

Note: The solar storage tank of a solar water heater should not be installed as part of a circulated hot water flow and return system in a building. The benefits of solar gain will be significantly reduced. If a circulated flow and return system is required, refer to **“Circulated Hot Water Flow and Return System”** on page 30.

CONNECTION SIZES

	52L series system	52H series system
• Hot water connection:	DN15 copper tube to DN15 olive compression fitting on TPR valve	DN15 copper tube to DN15 olive compression fitting on TPR valve
• Cold water connection:	DN15 copper tube to DN15 olive compression fitting on solar cold pipe	DN15 copper tube to R3/4 x DN15 olive union
• Relief valve connection:	Rp 1/2	Rp 1/2

WATER INLET AND OUTLET

All pipe work must be cleared of foreign matter before connection and purged before attempting to operate the water heater. All olive compression fittings must use brass or copper olives. Use thread sealing tape or approved thread sealant on all sealing threads other than a fitting with an O’ring seal.

An isolation valve and non-return valve must be installed on the cold water line to the water heater. An acceptable arrangement is shown in the diagram and on page 64 for multiple installations. Refer also to **“Hot Water Delivery”** on page 29 and to **“Mains Water Supply”** on page 28.

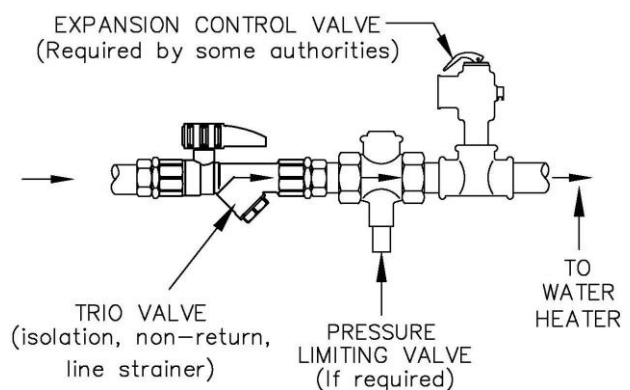

An expansion control valve is supplied in the parts kit supplied with the water heater.

The cold water isolation valve and expansion control valve must be accessible from ground or floor level to enable homeowner operation without the need for a ladder. They must not be installed either on the roof or in the ceiling space unless it is an accessible trafficable area. Extend the cold water line to the cold water inlet fitting on the shoulder of the solar cold pipe for an open circuit model and to the cold water inlet fitting on the solar storage tank for a closed circuit model.

A disconnection union must always be provided at the cold water inlet and hot water outlet of the solar storage tank to allow for disconnection of the solar storage tank.

The pipe work from the hot water outlet **must not** be installed in front of or prevent access to the electrical cover of the solar storage tank.

This water heater is intended to be permanently connected to the water mains and not connected by a hose-set. A braided flexible hose or semi-flexible connector may be used for connection to the water heater, where permitted by AS/NZS 3500.4.

Pipes must not be installed in direct contact with metal roofs. Where it is necessary to run piping across a metal roof, it must be fixed above the roof and surrounded with weatherproof insulation of a minimum thickness given in AS/NZS 3500.4. The insulation must be UV resistant if exposed. The insulation is to assist in freeze protection and to protect the metal roof against corrosion by water runoff over the copper pipe. Consideration should be made for thermal expansion and contraction of the roof material.

Exposed pipe work between the solar storage tank and the penetrations through the roofing material should be kept to a minimum to maintain the aesthetics of the installation.

Notes:

- Penetrations through the roofing material must be:
 - at the high point of the roof tile or metal sheet;
 - made neatly and kept as small as practicable;
 - waterproofed upon installation of the hot and cold pipes.

PIPE SIZES

To achieve true mains pressure operation, the cold water line to the water heater should be the same size or bigger than the hot water line from the water heater.

The pipe sizing for hot water supply systems should be carried out by persons competent to do so, choosing the most suitable pipe size for each individual application. Reference to the technical specifications of the water heater and local regulatory authority requirements must be made.

Pipe work, including that within the roof space, is to be securely fixed to prevent vibration.

IN-SERIES BOOSTER (IF INSTALLED)

The pipe work between the solar storage tank and an in-series booster has a minimum recommended pipe size of DN20, **MUST BE** of copper and be fully insulated with a closed cell type insulation or equivalent and in accordance with the requirements of AS/NZS 3500.4.

The insulation must be weatherproof and UV resistant if exposed. The insulation must be fitted up to the connections on both the solar storage tank and the in-series booster.

An isolation valve may be installed on the solar preheat water line to the in-series booster. The isolation valve must be of a full flow type if the in-series booster is a continuous flow water heater.

TEMPERATURE PRESSURE RELIEF VALVE

The temperature pressure relief valve is supplied in the parts kit. The temperature pressure relief valve must be fitted to the hot water outlet before the water heater is operated. Before fitting the relief valve, make sure the probe has not been bent.

To fit the relief valve:

- Seal the thread with an approved thread sealant such as Teflon tape - never hemp. Make sure tape does not hang over the end of the thread.
- Hand tighten the valve into the hot water outlet Tee (refer to the [installation diagrams](#) on pages 35 and 36).
- Using a spanner engaged on the valve's spanner flats and applying medium pressure to tighten, turn the relief valve an additional ½ to 1 ½ turns to secure and make the joint watertight, leaving the valve drain pointing downwards and away from the electrical cover.

⚠ Warning: Do not use a pipe wrench or poor fitting tool on the valve body nor over tighten the valve, as this could damage the valve and prevent safe operation.

- Operate the easing lever on the valve to check the smooth operation of the valve plunger. It is very important the lever is raised and lowered gently. The lever should move smoothly and without undue force.
- If the lever cannot be moved or is jerky in its movement, then the valve has been damaged and must be replaced.
- A copper drain line must be fitted to the temperature pressure relief valve (refer to "[Relief Valve Drain](#)" on page 59). The drain line **must not** be installed in front of or prevent access to the electrical cover of the water heater.
- The valve must be insulated with closed cell polymer insulation or similar (minimum thickness 9 mm) and the insulation installed so as not to impede the operation of the valve.

The insulation must be weatherproof and UV resistant if exposed.

Where a preformed insulation collar has been supplied with the temperature pressure relief valve in the parts kits, the installation of this insulation collar meets these requirements. It must be placed over the body of the valve and secured in position with the cable tie provided after the valve has been fitted to the water heater.

EXPANSION CONTROL VALVE

An expansion control valve is supplied in the parts kit and must be installed. Install the expansion control valve using a brass Tee, brass union and brass nipple on the cold water line to the water heater.

The expansion control valve must always be installed after the non-return valve and be the last valve installed prior to the water heater. Refer to [cold water connection diagram](#) on page 56. A copper drain line must be fitted to the expansion control valve. Refer to "[Relief Valve Drain](#)" on page 59.

The expansion control valve and its easing gear must be accessible from ground or floor level. It must not be installed either on the roof or in the ceiling space unless it is an accessible trafficable area. Extend the cold water line from the expansion control valve to the cold water inlet fitting on the water heater.

The valve, if installed within 500 mm of the water heater, must be insulated with closed cell polymer insulation or similar (minimum thickness 9 mm) and the insulation installed so as not to impede the operation of the valve. The insulation must be weatherproof and UV resistant if exposed.

RELIEF VALVE DRAIN

DN15 copper drain lines must be fitted to the temperature pressure relief valve and expansion control valve to carry the discharge clear of the water heater. Connect the drain lines to the valves using disconnection unions. The drain line from the valve to the point of discharge should be as short as possible, have a continuous fall all the way from the water heater to the discharge outlet and have no tap, valves or other restrictions in the pipe work.

The drain line **must not** be installed in front of or prevent access to the electrical cover of the water heater.

A drain line from a relief valve must comply with the requirements of AS/NZS 3500.4. A drain line must be no longer than nine (9) metres with no more than three bends greater than 45° before discharging at an outlet or air break. The maximum length of nine (9) metres for a drain line is reduced by one (1) metre for each additional bend required of greater than 45°, up to a maximum of three additional bends. Where the distance to the point of final discharge exceeds this length, the drain line can discharge into a tundish.

Subject to local regulatory authority approval, the drain lines from the temperature pressure relief valve and expansion control valve from an individual water heater may be interconnected.

The outlet of a drain line must not discharge onto roofing materials, roof gutters or onto paved areas. It must be in such a position that flow out of the pipe can be easily seen, but arranged so discharge will not cause injury, damage or nuisance. The termination point of a drain line must comply with the requirements of AS/NZS 3500.4.

In locations where water pipes are prone to freezing, drain lines must be insulated, must not exceed 300 mm in length and are to discharge into a tundish through an air gap of between 75 mm and 150 mm.

If a drain line discharges into a tundish, the drain line from the tundish must be not less than DN20. The drain line from a tundish must meet the same requirements as for a drain line from a relief valve.

Where a drain line crosses over a metal roof, the pipe work must be fully insulated with weatherproof lagging to offer corrosion protection to the metal roof against water runoff over the copper pipe. The insulation must be UV resistant if exposed.

For multiple installations the drain lines from several water heaters can discharge into a common tundish. Refer to [“Multiple Installations”](#) on pages 63 and 64.

⚠ Warning: As the function of the temperature pressure relief valve on this water heater is to discharge high temperature water under certain conditions, it is strongly recommended the pipe work downstream of the relief valve be capable of carrying water exceeding 93°C. Failure to observe this precaution may result in damage to pipe work and property.

CONNECTIONS – ELECTRICAL

The power supply to the water heater must not be switched on until the water heater is filled with water and a satisfactory megger reading is obtained.

All electrical work and permanent wiring must be carried out by a qualified person and in accordance with the edition of the Wiring Rules AS/NZS 3000 in force in the state or territory at the time of installation, and all local codes and regulatory authority requirements.

If this water heater is installed with an in-series booster, then the electric booster heating unit will not need to be connected to a power supply and the references to the electric booster heating unit, thermostat and boosting controls in these installation instructions will not be applicable to the installation.

Note: AS 3498 requires that a water heater provides the means to inhibit the growth of Legionella bacteria in potable water. This water heater can satisfy this AS 3498 requirement provided, where an in-series booster water heater is not installed, the electric booster is energised for a sufficient period each day and the electric booster thermostat setting is at least 60°C.

SOLAR STORAGE TANK

The solar storage tank with an electric booster heating unit must be directly connected to a 220 V - 240 V a.c. 50 Hz mains power supply with an isolating switch installed at the switchboard. It must be on its own circuit with the circuit breaker suitably rated for the booster heating unit.

The Wiring Rules AS/NZS 3000 requires a second and lockable isolating switch be installed adjacent to but not on or attached to the solar storage tank, and a residual current device (RCD) installed in the electrical circuit to the water heater. The second and lockable isolating switch and RCD may not be required if the installation of this solar storage tank is considered a repair under Clause 1.9.3.2 of the Wiring Rules, i.e., the installation of the solar storage tank is a straight change-over with a straight disconnect / reconnect of the wiring and where there is no modification to the electrical wiring of the final subcircuit or no increase in electrical load above the circuit capacity.

A flexible 20 mm conduit is required for the electrical cable to the solar storage tank. The conduit is to be connected to the unit with a 20 mm terminator.

Connect the power supply wires directly to the terminal block and earth tab connection, ensuring there are no excess wire loops inside the front cover. The temperature rating of the power supply wires insulation must suit this application, or the wiring protected by insulating sleeving with an appropriate temperature rating if it can make contact with the internal storage cylinder. The temperature of the internal storage cylinder can reach 95°C during its operation.

The water heater is more suited for the booster heating unit to be connected to either a continuous, or a time of use, or an extended Off-Peak (overnight and day) electricity supply. A timer can also be used to control the boosting periods and help maximise solar savings. Refer to “**Booster Control**” on page 61.

The booster heating unit may be connected to an Off-Peak (overnight) electricity supply, however this will only allow the booster to heat the water overnight. If this type of connection is considered, care must be taken to ensure there is sufficient boost capacity to meet the household’s full day and night’s hot water supply during periods of no or low solar gain, particularly in cold weather. **Temperature Redistribution** (refer to page 23) is more evident with this type of electricity supply connection and its implications should be discussed with the householder.

Discuss the power supply and hot water usage requirements with the householder.

If water and / or power are not available on completion of installation, leave the isolation switch in the meter box in the off position and place a warning label “Do not turn on electricity until the water heater is filled with water and the water heater has been commissioned” on the electrical isolating switch.

THERMOSTAT SETTING

The thermostat is adjustable from 60°C to 70°C. The factory setting of the thermostat is 60°C. The thermostat is adjusted by turning the adjuster anticlockwise to decrease the temperature setting and clockwise to increase the temperature setting. Only adjust the temperature setting when the isolating switch is switched off at the switchboard.

The thermostat has a safety cut-out (also called an over-temperature energy cut-out) that will de-energise the element should the temperature within the tank reach 83°C whilst the element is activated. This safety cut-out is not resettable. This cut-out is of a type that will not activate due to solar heating of the water in the storage tank above this temperature whilst the element is not energised.

For reasons of safety and economy, we advise the thermostat be set at the lowest temperature that will provide sufficient hot water during periods when boosting is required. Rheem recommends the thermostat is set at 60°C to maximise solar contribution. Discuss the thermostat setting requirements with the householder.

LIGHTNING PROTECTION

If the national or local installation codes or Regulatory Authorities require a Lightning Protection system be installed, then an equipotential connection must be provided between the metal pipes of the solar circuit and the common earthing system as well as between collector and tank using a 16 mm² minimum cross-section copper yellow-green conductor.

If there is an existing lightning protection system (LPS) on the building, the hot water system may be integrated with it – seek agreement from a structural engineer or the building owner. The hot water system may be earthed using a stake, with the earth electrode positioned outside the walls of the building.

The hot water system earth electrode should be connected to the common building earthing system using an equipotential conductor also of 16 mm² minimum cross-section.

Any lightning protection work must be carried out exclusively by a competent company or persons.

BOOSTER CONTROL

The isolating switch(s) installed at the switchboard and adjacent to the solar storage tank (if installed) should be left switched on.

Leaving the isolating switch switched on will also provide a sufficient period of time each day for the booster heating unit to operate, if required, to satisfy the requirements of AS 3498.

Timer Control Switch

A suitably rated timer control switch can be installed and will help maximise energy savings with an electrically boosted solar water heater connected to a **continuous, time of use or extended Off-Peak (overnight and day)** electricity supply.

If used with an extended Off-Peak (overnight and day) electricity supply, the timer switch should:

- be operated by a continuous power supply on its own circuit from the switchboard with the booster heating unit operated by the Off-Peak power supply.

A double pole isolating switch is required to be installed at the switchboard to simultaneously isolate both circuits.

or

- be of a type which has an internal rechargeable battery to keep time when the power supply is not available to the timer.

Refer to “[Booster Control](#)” on page 14 for information on programming the timer.

TIMER CONTROL SWITCH WIRING DIAGRAM

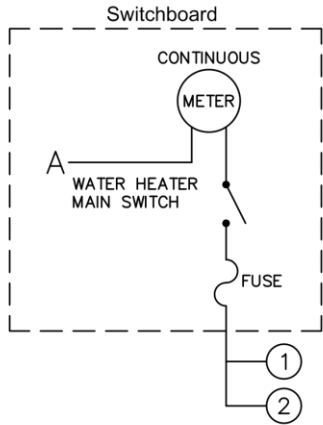

CONTINUOUS
POWER SUPPLY

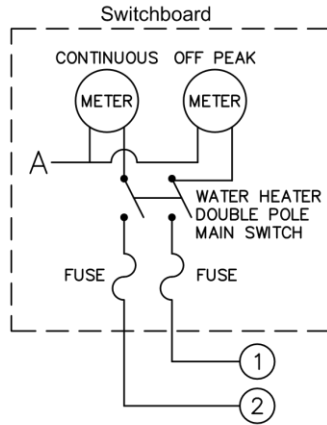

EXTENDED OFF-PEAK
POWER SUPPLY

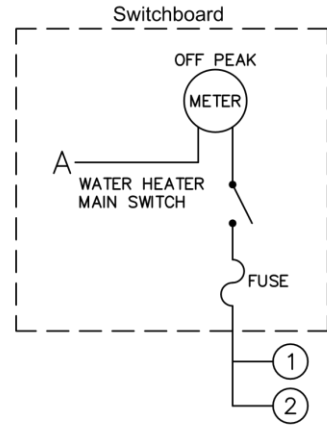

EXTENDED OFF-PEAK
POWER SUPPLY
(timer with rechargeable battery)

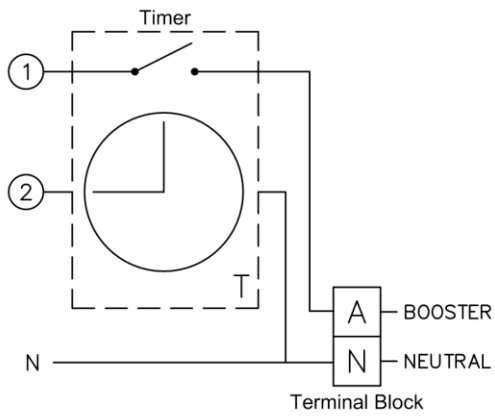

TIMER WITHOUT CONTACTOR

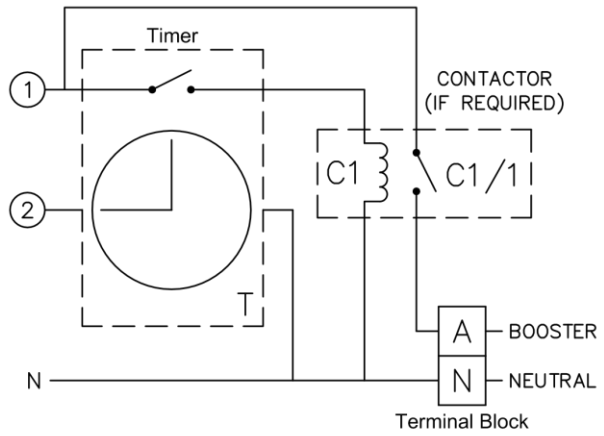

TIMER WITH CONTACTOR (if required)

MULTIPLE INSTALLATIONS

A multiple installation of Rheem solar Premier Hiline water heaters on a single manifold or multiple manifolds is possible, using the Rheem Equa-Flow® manifold principal, where large volumes of hot water are required.

The system may be installed with the solar water heaters as preheaters and their electrical heating units not be connected to a power supply. Rheem commercial or heavy duty water heaters should be installed in series with the solar water heaters to boost the water temperature during periods of poor or no solar gain.

Alternatively, the solar water heaters can be installed with their heating units connected to a power supply and without in series booster water heaters.

An over temperature protection device should be fitted to each thermosiphon water heater when used as a preheater to an inline booster water heater.

The cold water and hot water manifolds must be designed to balance the flow from each solar storage tank. To achieve this, there are basic installation requirements and principles which must be followed:

1. The maximum number of solar storage tanks in a bank should be five (5), however several banks of solar storage tanks can be installed.
2. The hot water line from the manifold must leave from the opposite end to which the cold water line enters the manifold.
3. The solar storage tanks must be of the same model.
4. The cold water line, cold and hot water headers and hot water line must be sized to meet the requirements of both AS/NZS 3500.4 and the application.
5. A non-return valve, isolation valve and if required a pressure limiting valve, must be installed on the cold water line to the system.
6. A full flow gate valve or ball valve (not stop taps, as used on a single solar storage tank installation) must be installed on both the cold water branch and hot water branch of each solar storage tank.
7. The expansion control valve for each solar storage tank can be installed into a brass Tee on the cold branch to the tank after the gate valve or ball valve.
8. Non-return valves or pressure limiting valves **must not** be installed on the branch lines to the solar storage tanks.
9. All fittings, valves and branch lines must be matched sets all the way along the manifold.
10. Sufficient space must be left to enable access, servicing or removal of each solar storage tank.
11. The temperature pressure relief valve drain line from each solar storage tank can terminate at a common tundish with a visible air break at each drain discharge point. Refer to “Relief Drain Line” on page 59 and to the [diagram](#) on page 63.

Note: A temperature-operated bypass valve(s) or primary temperature control valve(s) should be installed prior to the in-series water heater(s) if the water heater has either an over temperature energy cut-out which can be permanently disabled by high temperature hot water or a maximum recommended inlet supply temperature less than the temperature of water which can be supplied by this solar water heater.

Refer to the [diagram on page 64](#) for installation and plant layout details.

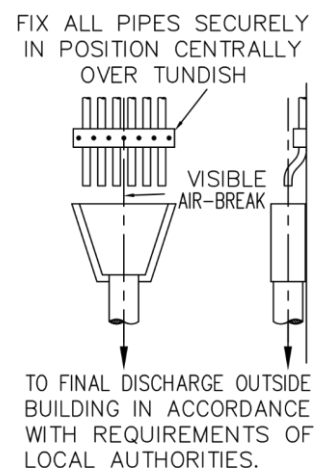

**TPR Valve Drain Line
Common Discharge Point**

RHEEM COMMERCIAL SOLAR THERMOSIPHON – DOUBLE ARRAY

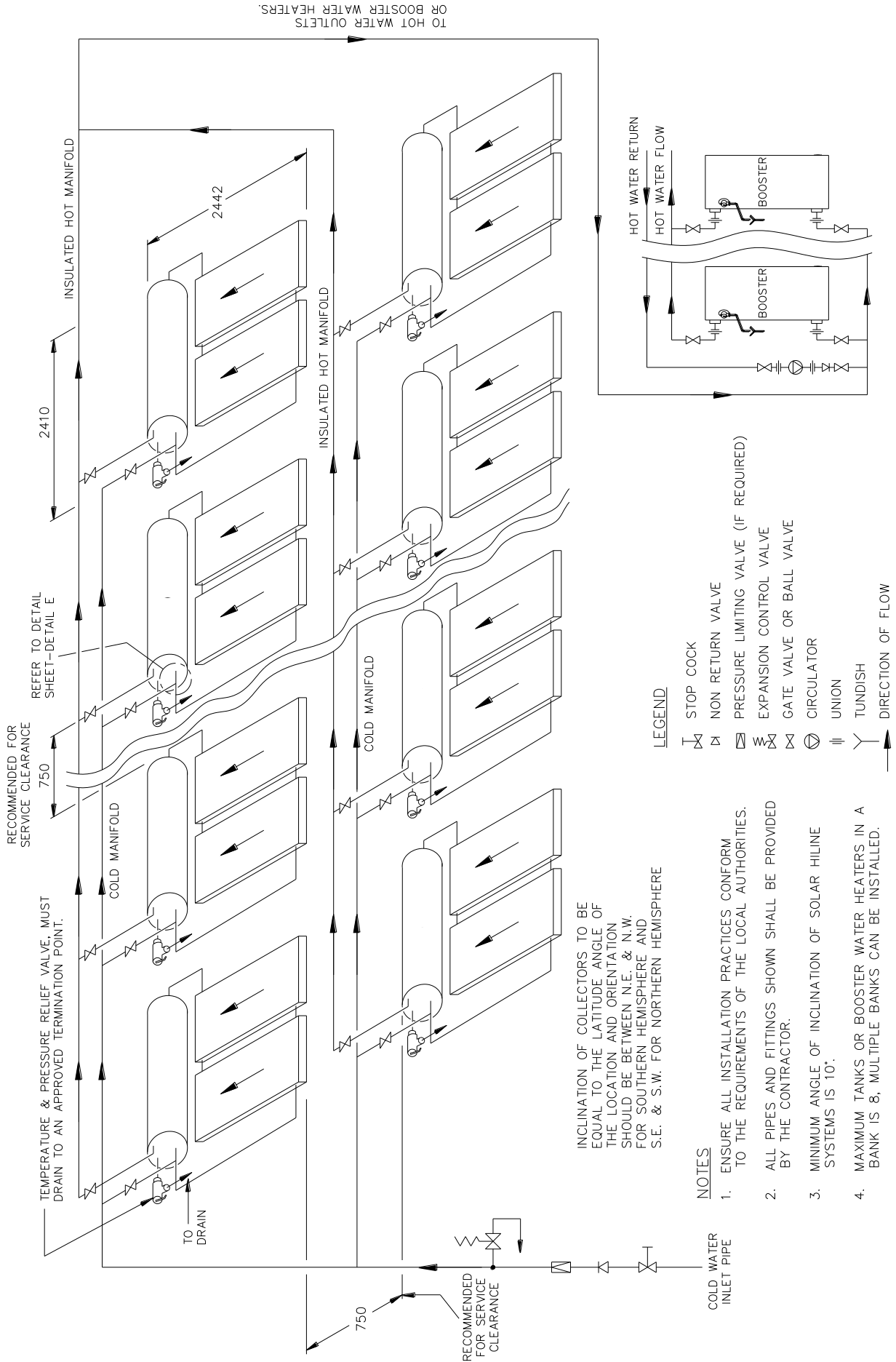

COMMISSIONING

TO FILL AND TURN ON THE WATER HEATER

The power supply to the solar storage tank must not be switched on until the water heater is filled with water and a satisfactory megger reading is obtained.

- Open all of the hot water taps in the house (don't forget the shower).
- Open the isolation valves fully on the cold and hot water branches to the water heater(s) in a bank.
- Open the cold water isolation valve fully on the cold water line to the water heater(s).

Air will be forced out of the taps.

- Close each tap as water flows freely from it.
- Check the pipe work for leaks.
- Inspect for leaks at the temperature pressure relief valve connection to the water heater.

If a leak is detected, close the cold water isolation valve fully and relieve pressure from the water heater by either operating the easing lever on the temperature pressure relief valve or opening a hot tap. Remove the valve and all of its thread sealant from the threads of the valve. Reapply new thread sealant and refit the valve. Refer to the procedure in ["Temperature Pressure Relief Valve"](#) on page 58.

- Operate the easing lever on the temperature pressure relief valve to check the smooth operation of the valve plunger and that water discharges freely from the drain line. It is very important the lever is raised and lowered gently. The lever should move smoothly and without undue force.

If the lever cannot be moved or is jerky in its movement, then the valve has been damaged and must be replaced.

- If the installation is of a closed circuit system, fill the closed circuit heat exchanger and solar collectors with the closed circuit fluid. Refer to ["Closed Circuit Fluid"](#) on page 66.

A commissioning kit is available from Rheem for the purpose of filling the closed circuit. Contact Rheem or your local Rheem Solar Water Heater Distributor for details.

- Switch on the electrical supply at the water heater isolating switch(s) on the switchboard and at the isolating switch(s) at the solar storage tank(s) (if installed).
- Set the timer if one is installed. Refer to ["Booster Control"](#) on page 61.
- Remove the packaging / covers from the solar collectors. The packaging / covers must be removed completely prior to the permanent operation of the water heater.
- Complete the installation check list. Refer to ["Installation Check List"](#) on page 69.

Explain to the householder or a responsible officer the functions and operation of the solar water heater and the timer if one is installed. Upon completion of the installation and commissioning of the water heater, leave this guide with the householder or responsible officer.

TO TURN OFF THE WATER HEATER

If it is necessary to turn off the water heater on completion of the installation, such as on a building site or where the premises is vacant, then:

- Ensure the collectors are covered with an opaque material if the installation is of a closed circuit system(s),
- Switch off the electrical supply at the water heater isolating switch(s) on the switchboard and at the isolating switch(s) at the solar storage tank(s) (if installed),
- Close the cold water isolation valve at the inlet to the water heater(s) to shut down the entire system, or;
- Close the isolation valves on the cold and hot water branches to shut down an individual water heater in a bank.

CLOSED CIRCUIT SYSTEMS

The solar collectors and tank heat exchanger are connected together to create a sealed, closed circuit that is entirely separate from the potable water in the storage cylinder. The circuit is filled with Coolblend heat transfer fluid concentrate and water. Under no circumstances can any fluids other than provided by Rheem be used as the heat transfer fluid. Only potable water can be used in conjunction with the heat transfer fluid concentrate.

Only trained and qualified installers are permitted to fill the closed circuit.

⚠ Warnings: Before charging the solar heat exchanger and collectors with the closed circuit fluid:

- **Important:** It is recommended the solar storage tank must be filled with water and pressurised.
- The solar collectors must be covered with an opaque material.

Covering the collectors prevents solar gain and heating from occurring, keeping the collectors and closed circuit fluid cooler during the commissioning procedure. This will reduce the risk of scalding and burn injury by preventing the collector surface and closed circuit fluid from becoming very hot.

If not covered with an opaque material, it is possible for the solar collectors to generate enough heat to close the Over Temperature Protection valve (if one is installed) during the commissioning procedure. This will create a vapour lock that prevents complete filling of the closed circuit, which will reduce system performance and lead to customer complaints.

- The Over Temperature Protection valve (if one is installed) must be covered with a cloth soaked in cold water.

This will assist in keeping the valve as cool as possible, so it remains in the open position during the commissioning procedure.

Coolblend Heat Transfer Fluid and Concentration

The required quantity of Coolblend heat transfer fluid concentrate must be mixed with the correct quantity of water to achieve the correct closed circuit fluid for the system. Failure to mix the closed circuit fluid correctly may void the Rheem warranty.

The Coolblend heat transfer fluid concentrate is supplied at a quantity of 1.5 litres per bottle. The table below lists the percentage of Coolblend concentrate fluid in the closed circuit of each system and the recommended minimum ambient temperature for the system, for the number of bottles supplied with each system.

Generally, the concentration of Coolblend concentrate in the closed circuit required for a minimum ambient temperature of -7°C is 19%, -10°C is 25%, -12°C is 30%, and -17°C is 37%. Coolblend concentrations over 50% become proportionally less thermally efficient and are not recommended.

An additional bottle of Coolblend heat transfer fluid concentrate may need to be purchased and added to the closed circuit if the installation is in an area which may experience a temperature lower than that shown in the table below. Failure to mix the correct volume of Coolblend concentrate for the minimum temperature which may be experienced may void the Rheem warranty.

The Coolblend concentrate can be siphoned into the closed circuit system using a known quantity of fluid.

System	Closed Circuit Volume	Coolblend Concentrate Supplied	Percentage Concentrate in Closed Circuit	Minimum Ambient Temperature
52H180 1 x NPT200, L, CSA2007 collector	4 litres	1 x 1.5 litre bottle	37%	-17°C
52H180 1 x SPA2000 collector	6 litres	1 x 1.5 litre bottle	25%	-10°C
52H300 2 x NPT200, L, CSA2007 collectors	8 litres	1 x 1.5 litre bottle	19%	-7°C
52H300 2 x SPA200 collectors	12 litres	2 x 1.5 litre bottles	25%	-10°C
52H300 3 x NPT200, L, CSA2007 collectors	10 litres	2 x 1.5 litre bottles	30%	-12°C

Systems Installed with an Over Temperature Protection (OTP) System

An Over Temperature Protection system installed on a closed circuit system incorporates an OTP valve installed between the end of the solar hot pipe and the closed circuit inlet of the solar storage tank. The OTP valve is a temperature actuated valve that is designed to close when exposed to high temperature closed circuit fluid.

Ensure the OTP valve is covered with a cloth soaked in cold water and the solar collectors are covered with an opaque material during the commissioning procedure of the closed circuit. This is to keep the valve as cool as possible and ensure it remains in the open position during the commissioning procedure.

If the OTP valve was to close and the closed circuit is only partially filled the solar performance will be much reduced resulting in a no hot water complaint. In addition, excessive noise can be generated from the system leading to possible disturbance and irritation to the householders.

Coolblend Heat Transfer Fluid Concentrate Handling and Safety

Caution: Although the Coolblend heat transfer fluid concentrate is non-toxic and non-hazardous, care must be taken not to accidentally consume or spill any of the Coolblend concentrate when handling. Only use approved closed circuit concentrate. If required, a Safety Data Sheet (SDS) is available from Rheem.

While the closed circuit fluid is non-toxic to humans, it does have an adverse effect on water stored in rainwater tanks. It can cause an unpleasant odour to develop and result in the rainwater tank having to be drained and cleaned. Refer to "[Rainwater Collection System](#)" on page 28.

⚠ Warning: Wear protective gloves and clothing, and eye and face protection when handling the Coolblend concentrate. The concentrate can cause skin and serious eye irritation.

⚠ Warning: Although non-toxic, the following first aid advice and procedures should be followed if the Coolblend closed circuit concentrate comes into human contact or is spilt:

- **Swallowed**

If swallowed **do not** induce vomiting. If vomiting occurs, lean person forward or place on left side (head-down position, if possible) to maintain open airway and prevent aspiration. Observe the patient carefully.

Never give liquid to a person showing signs of being sleepy or with reduced awareness, i.e. becoming unconscious.

Give water to rinse out mouth, then provide liquid slowly and as much as casualty can comfortably drink. Seek medical advice.

- **Eyes**

Wash out immediately with fresh running water. Ensure complete irrigation of the eye by keeping eyelids apart and away from eye and moving the eyelids by occasionally lifting the upper and lower lids. Continue rinsing with flowing lukewarm water.

Remove contact lenses, if present and easy to do. Removal of contact lenses after an eye injury should only be undertaken by skilled personnel.

Seek medical attention without delay if eye irritation or pain persists or recurs.

- **Skin**

Immediately remove all contaminated clothing, including footwear. Flush skin and hair with running water (and soap if available). Wash contaminated clothing before reuse.

Seek medical attention in event of irritation.

- **Inhaled**

If fumes are inhaled remove the person from contaminated area to seek fresh air.

Lay person down. Keep warm and rested.

Prostheses such as false teeth, which may block airway, should be removed, where possible, prior to initiating first aid procedures.

- **Spilt**

Stop leak source, absorb with a dry agent and eliminate any ignition sources nearby.

To Fill the Closed Circuit

It is necessary to fill the heat exchanger and solar collectors with closed circuit fluid before the water heater can be operated. Refer to [diagram](#) on page 68.

Note: Care must be taken to ensure there is no spillage of the closed circuit fluid onto the roof surface, particularly if the roof is part of a rain water collection system. Any spilled closed circuit fluid must be cleaned up immediately and the roof surface cleaned of any fluid residue.

To fill the heat exchanger:

- Remove the retaining clip and 200 kPa pressure relief valve from the tank vent socket located on the right hand end of the solar storage tank.

This is the fill level for the closed circuit fluid and will allow air to escape during filling.

- Connect a hose to the Fill / Drain Valve port located at the bottom right hand corner of the right hand solar collector.
- Open the Fill / Drain Valve by loosening (but do not remove) the valve screw on the drain port a few turns.
- Using a funnel placed in the end of the hose, pour water into the system through the funnel until water flows from the vent socket. **Note:** the funnel must be held at a level that is above the vent socket.
- Close the Fill / Drain Valve by tightening the valve screw.
- Insert the 200 kPa pressure relief valve into the vent socket and secure with the retaining clip.
- Pressurise the closed circuit system up to 200 kPa and leave for ten minutes.
- Check the system for leaks at all connections.
- If no leaks are evident:
 - open the Fill / Drain Valve by loosening (but do not remove) the valve screw on the drain port a few turns,
 - remove the retaining clip and 200 kPa pressure relief valve,
 - using a funnel placed in the end of the hose, pour the required contents of the Coolblend concentrate fluid bottle(s) into the system through the funnel,
 - Water will be displaced through the vent socket as the Coolblend concentrate is added.
 - add a further 500 ml of water to flush the Coolblend concentrate through the hose and into the collector.
- Close the Fill / Drain Valve by tightening the valve screw.
- Insert the 200 kPa pressure relief valve into the vent socket and secure with the retaining clip.
- Pressurise the closed circuit system up to 200 kPa and leave for ten minutes.
- Check the system for leaks at all connections.
- When satisfied there are no leaks present, remove the hose from the Fill / Drain Valve.

Clean up any spilt closed circuit fluid.

Note: The closed circuit fluid level should be checked every five (5) years or at each major service and if required topped up or replaced.

The closed circuit fluid contains food grade additives (rust inhibitor, anti-freeze agent, colour) and is harmless to the environment. However, it is good practice to recover any excess closed circuit fluid and remove from site.

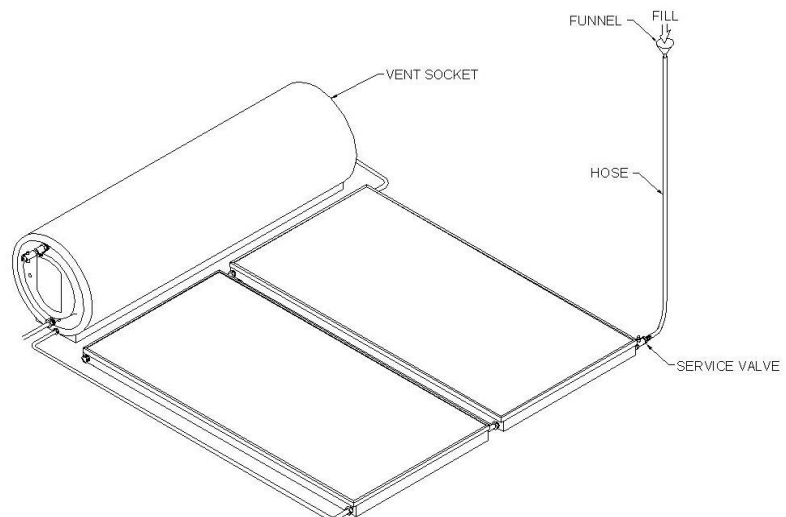

Filling The Closed Circuit With Closed Circuit Fluid

INSTALLATION CHECKLIST

Prior to handover, complete the final check list:

1. System is installed as per the installation instructions[]
2. Water is connected, turned on and solar storage tank is filled.....[]
3. Closed circuit is filled with correct concentration of fluid and has been commissioned[]
4. All mechanical fixings are secured[]
5. Collector rail has a rise of 12-15 mm per collector on the hot outlet side of the solar collectors if installed directly onto the roof[]
6. Collector rail is either horizontal or higher on the hot outlet side of the solar collectors if part of a frame[]
7. Protective plastic film removed from tank (if fitted)[]
8. Covers removed from collectors.....[]
9. Pipe, conduit penetrations through the roof have been sealed correctly[]
10. Roof tiles put back into position.....[]
11. Roof flashing watertight.....[]
12. System checked for water (and heating fluid) leaks and pipe connections are correctly tightened.....[]
13. Cold and hot water piping checked for water leaks.....[]
14. Drain pipes free of any obstruction.....[]
15. All pipe work clipped where necessary[]
16. Electrical power to the booster is switched on (if required).....[]
17. Operation of booster checked[]
18. Air bled from taps[]
19. Instruct the householder on the water heater system use and leave manual with the householder[]

DRAINING THE CLOSED CIRCUIT FLUID – 52H SERIES

It may be necessary to drain the solar collectors and heat exchanger of a closed circuit system during maintenance. Draining the solar collectors and heat exchanger of closed circuit fluid should be conducted within three (3) hours of sunrise when the sun is low in the sky. The closed circuit fluid temperature inside the solar collectors should be lower as the solar collectors would not have had as much chance to gain as much heat as later in the day.

⚠ Warning: Exercise care to avoid splashing of closed circuit fluid, as fluid discharged from the solar collectors may be of a very high temperature.

Note: Care must be taken to ensure there is no spillage of the closed circuit fluid onto the roof surface. Any spilled closed circuit fluid must be cleaned up immediately and the roof surface cleaned of any fluid residue. The closed circuit fluid discharged from the solar collectors can render the water in a rainwater tank unusable.

Draining the Solar Collectors and Heat Exchanger

1. Cover the solar collectors with an opaque material to prevent absorption of solar energy. If fitted, cover the OTP valve with a cloth soaked in cold water.

Failure to cover the solar collectors may cause a safety issue.

2. Open a hot water tap and allow the water to run for five minutes immediately prior to draining the solar storage tank.

This will assist in the transfer of any heat from high temperature closed circuit fluid in the heat exchanger and solar collectors to the water in the solar storage tank.

3. Close the hot water tap.

4. Attach one end of a hose to the valve drain port of the fill drain valve assembly and place the other end into a container of sufficient volume to hold the closed circuit fluid.

Refer to the [table](#) on page 66 for the volume of closed circuit fluid in the closed circuit of the water heater.

5. Place an absorbent cloth on the roof under the fill drain valve assembly prior to loosening the screw. This will assist in catching any spilt closed circuit fluid.

6. Loosen (but do not remove) the valve screw on the fill drain valve assembly a few turns to open the valve drain port.

This will release the pressure in the closed circuit.

7. Very carefully, remove the retaining clip securing the closed circuit relief valve on the right hand side of the solar storage tank and remove the relief valve.

⚠ Warning: Relieved air or closed circuit fluid may be hot.

Closed circuit fluid will drain through the hose.

8. Allow the closed circuit fluid to drain into a container and dispose of in accordance with the relevant local authority.

⚠ Warning: Closed circuit fluid may be hot.

9. If refilling the closed circuit, refer to [“To Fill the Closed Circuit”](#) on page 68.

10. When satisfied the closed circuit is drained, tighten the valve screw on the fill drain valve assembly.

- Remove the hose from the valve drain port of the fill drain valve assembly.

11. Refit the closed circuit pressure relief valve on the right hand side of the solar storage tank and secure with the retaining clip.

12. To refill the solar collectors and closed circuit, refer to [“To Fill the Closed Circuit”](#) on page 68.

DRAINING AND FLUSHING THE SOLAR STORAGE TANK

DRAINING AND FLUSHING THE SOLAR STORAGE TANK AND COLLECTORS

It may be necessary to drain or flush the solar storage tank of an open or closed circuit system or the solar collectors of an open circuit system during maintenance or if there is sediment in the water supply. This should be conducted in the morning, within three (3) hours of sunrise when the sun is low in the sky. The water or closed circuit fluid temperature inside the solar collectors should be lower as the solar collectors would not have had as much chance to gain as much heat as later in the day.

⚠ Warning: Exercise care to avoid splashing of water, as water discharged from the solar storage tank and solar collectors may be of a very high temperature.

Note: The water discharged from the solar storage tank and solar collectors may contain sediments and should be diverted away from any section of roof which is part of a rainwater collection system.

Prior to draining and / or flushing the solar storage tank and / or solar collectors:

Open and Closed circuit system

1. Cover the solar collectors with an opaque material to prevent absorption of solar energy and the transfer of heat to the solar storage tank. If fitted, cover the OTP valve with a cloth soaked in cold water.

Failure to cover the solar collectors may cause a safety issue.

2. Open a hot water tap and allow the water to run for five minutes immediately prior to draining or flushing the solar storage tank and / or solar collectors.

This will assist in the transfer of any high temperature water in the solar collectors to the solar storage tank of an open circuit system or heat from high temperature closed circuit fluid in the heat exchanger and solar collectors to the water in the solar storage tank of a closed circuit system.

3. Close the hot water tap.
4. Turn off the water heater. Refer to **"To Turn Off the Water Heater"** on page 65.
5. Ensure all hot water taps are closed.

Closed circuit system

6. Attach a hose to the valve drain port of the fill drain valve assembly.

Place the end of the hose into a container.

Place an absorbent cloth on the roof under the fill drain valve assembly prior to loosening the screw. This will assist in catching any spilt closed circuit fluid.

7. Loosen (but do not remove) the valve screw on the fill drain valve assembly a few turns to open the valve drain port.

This will release the pressure in the closed circuit.

8. When the pressure is relieved, tighten the valve screw on the fill drain valve assembly.
9. Very carefully, remove the retaining clip securing the closed circuit relief valve on the right hand side of the solar storage tank and remove the relief valve.

Note: It is important the closed circuit is not pressurised whilst the storage tank is unpressurised.

⚠ Warning: Relieved air or closed circuit fluid may be hot.

Open and Closed circuit system

10. Operate the temperature pressure relief valve lever - do not let the lever snap back or you will damage the valve seat. **It is very important the lever is raised and lowered gently.**

Operating the lever will release the pressure in the solar storage tank.

Draining and Flushing the Solar Storage Tank

Open circuit system

11. Undo the union at the cold water inlet to the solar cold pipe.
12. Undo the fitting and remove the solar cold pipe from the solar storage tank.

Connect a hose to the tank connection. Let the other end of the hose go to a drain.

Closed circuit system

13. Undo the union at the cold water inlet to the solar storage tank.

Connect a hose to the tank connection. Let the other end of the hose go to a drain.

Open and Closed circuit system

14. Open the temperature pressure relief valve by holding the lever in the raised position.

This will let air into the solar storage tank and allow the water to drain through the hose.

15. If flushing the solar storage tank:

- Disconnect and remove the booster heating unit.
- Place a hose inside the tank.
- Open the isolation valve to the hose.
- Allow the hose to run until water runs clear from the hose connected to the cold water connection.
- When satisfied the solar storage tank is flushed, close the cold water isolation valve to the hose and remove the hose from the tank.
- Replace and reconnect the booster heating unit.

16. When satisfied the solar storage tank is drained and / or flushed, remove the hose from the cold water inlet connection.

Open circuit system

17. Reconnect the solar cold pipe to the solar storage tank and cold water pipe work to the solar cold pipe.

Closed circuit system

18. Reconnect the cold water pipe work to the solar storage tank.
19. Refit the closed circuit pressure relief valve on the right hand side of the solar storage tank and secure with the retaining clip.
20. Remove the hose from the valve drain port of the fill drain valve assembly.

Draining and Flushing the Solar Collectors (Open Circuit System)

21. From the bottom end of the solar collectors, unscrew and remove the end plug.
Connect a hose to the collector connection. Let the other end of the hose go to a drain.
22. From the top end of the solar collectors, unscrew and remove the end plug.
This will let air into the collector and allow the water to drain through the hose.
23. If flushing the solar collector:
 - Connect a hose to the top collector connection. Let the other end of the hose go to a drain.
 - Open the cold water isolation valve to the water heater.
Water will flow through the solar cold and solar hot pipes into the solar collectors.
 - Allow water to flow from the solar collectors until it is clear of any sediment.
 - When satisfied the solar collectors are flushed, close the cold water isolation valve to the water heater.
24. When satisfied the solar collectors are drained or flushed, remove the hose(s) and reconnect the end plug(s).

Fill and Turn On the Water Heater

After the solar storage tank and solar collectors have been drained or flushed:

- Fill and turn on the water heater. Refer to [“To Fill and Turn On the Water Heater”](#) on page 65.
- Remove the covering from the solar collectors.

This page is intentionally blank.

This page is intentionally blank.

This page is intentionally blank.



INSTALLATION REPORT

Dear Installer / Customer

A copy of this installation report filled out in full and signed can be attached to an STC Assignment Form (where applicable) as a method to demonstrate proof of installation. It can be copied and kept for your records.

Installer, please complete all details below

Owner's Name							
Installation Address							
Suburb		Telephone Home					
State		Work					
Postcode		Mobile					
Email Address							
Installing Company / RSS / Agent		No. of Stories of Install		Single	Other		
Installer's Name		Installation Date					
Type of Installation (please circle)	Replace Complete Solar System	Replace Solar Tank	Replace Electric or Gas	Replace Heat Pump	New Building	New Install on Existing Building (not replacing a unit)	Other
System Model No		System Type					
Tank Model No		Tank Serial No					
Collector Model No		No of Collectors					
Collector Serial No's	1)	2)	3)	4)			
Electric Booster (please circle)	Electric continuous	Off Peak 1 (night)	Off Peak 2 (night & day)	Solar Preheat only			
Electric Booster Control (please circle)	None	Timer	Manual Switch	Other			
Gas Booster (if installed)	Model No		Serial No				

If replacing a water heater, please give details

Brand		Model No		Electric	Gas
If a Rheem unit	Tank Serial No		Date of manufacture		
Collector Serial No's	1)	2)	3)	4)	
Comments					
Signature:	Installer:		Customer:		
Date					

This page is intentionally blank.

This page is intentionally blank.

