

LEGEND

- ⊥ STOP COCK
- ⊗ NON RETURN VALVE
- ⊠ PRESSURE LIMITING VALVE (IF REQUIRED)
- ⊞ COLD WATER RELIEF VALVE
- ⊞ GATE VALVE
- ⊙ CIRCULATOR
- ⊗ FIXTURES
- ➔ DIRECTION OF FLOW
- || UNION
- Y TUNDISH

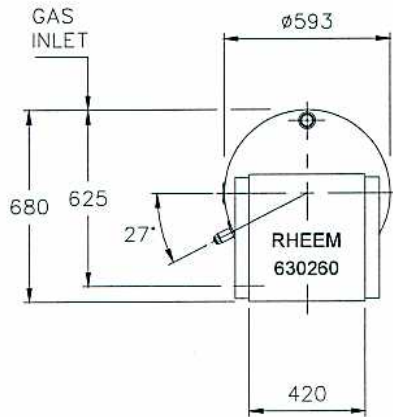

- INLET OUTLET CONNECTIONS: -**
 RP 1 1/4 / 32 (1 1/4 B.S.P. INTERNAL)
- T&PR VALVE CONNECTIONS: -**
 RP 3/4 / 20 (3/4 B.S.P. FEMALE)
- GAS INLET CONNECTION: -**
 RP 1/2 / 15 (1/2 B.S.P. FEMALE)
- T&PR VALVE SETTING: -**
 1000 kPa

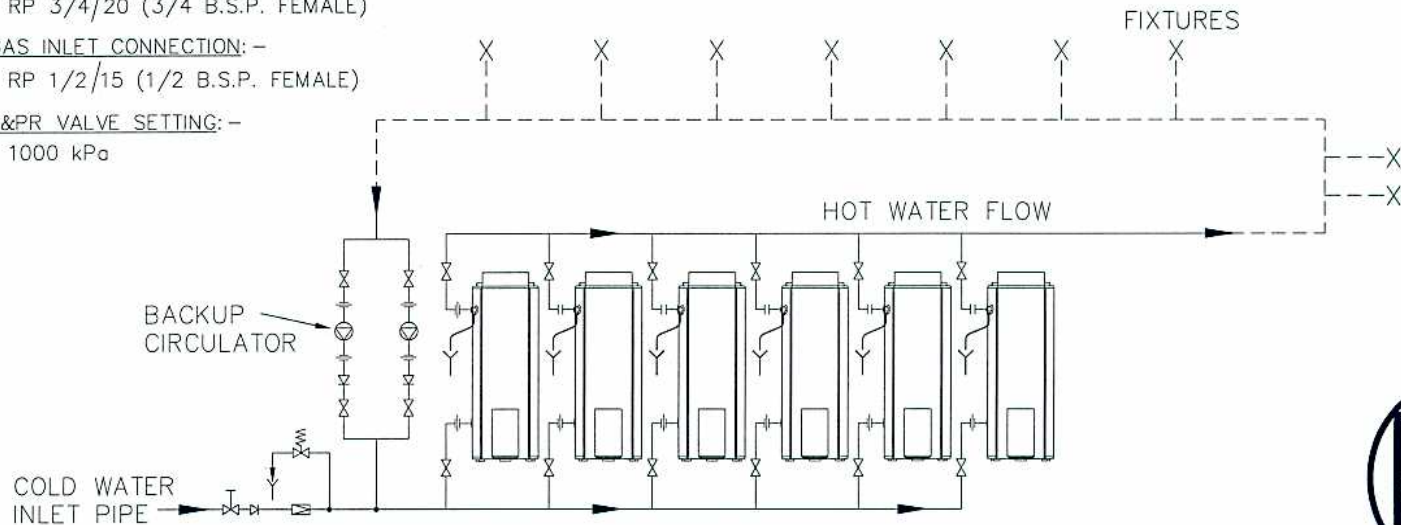

NOTES:

- N1. MINIMUM SPACE BETWEEN WALL AND BACK OF WATER HEATER IS 100mm.
- N2. A MINIMUM OF 900mm SHOULD BE LEFT IN FRONT OF THE WATER HEATER FOR ACCESS, SERVICING AND WATER HEATER REMOVAL.
- N3. EXTERNAL WATER HEATERS MUST BE INSTALLED WITH THE BACK OF THE WATER HEATER AGAINST A SOLID WALL.

RHEEM WATER HEATERS HEAVY DUTY GAS 6 x 630260

