

RHEEM TANKPAK® Series

Single Unit – Tankpak 1

Rheem Tankpak 1 comes with a single continuous flow water heater (CFWH), a storage tank, a pump, controller and an optional tank mounting bracket kit.

The Tankpak 1 units are available in internal (TPI01) and external (TPE01) models with natural or propane gas. All models can be mounted on a vertical wall (W) or on the storage tank (F) (tank mounting bracket is supplied by Rheem).

Typical Installation

TANK MOUNT- FRONT VIEW

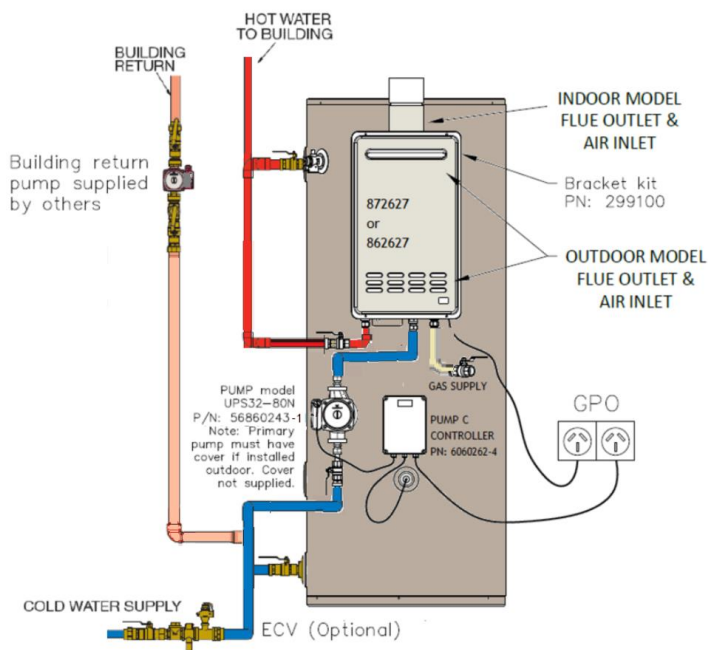

WALL MOUNT- FRONT VIEW

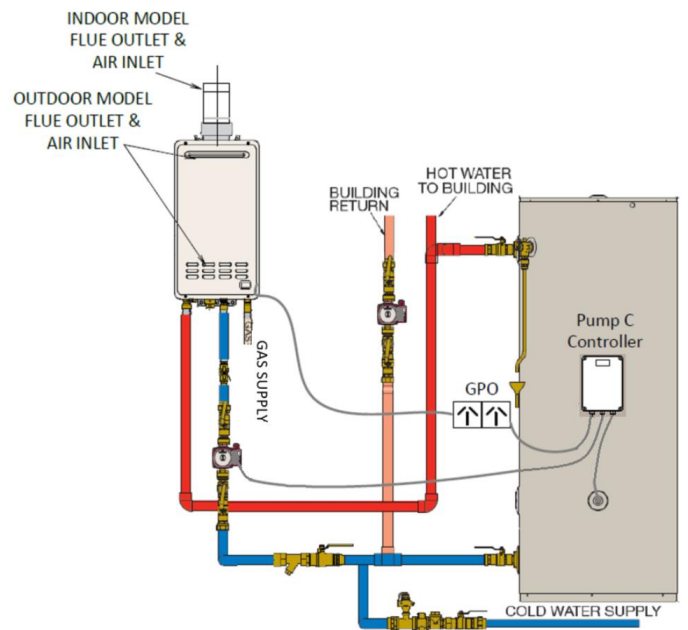

NOTE: Front clearances for continuous flow water heater (CFWH) are 600mm for indoor and 800mm for outdoor models.

Tankpak 1 models are supplied with tank, pump, controller and an optional tank mounting bracket kit separately.

Components

CFWH	Storage Tank	Pump	Controller	Bracket Kit (Optional)
Internal Model- 862627*F	325L- 61034050 or	UPS32-80N	PUMP/C Controller	TP01 Gas Boost Mounting
External Model- 872627*F	410L- 61043050	56860243-1	6060262 – 4	Kit 299100

Model Numbers (excluding gas type)

Wall Mount		Tank Mount	
TPE01*WS/1340	TPI01*WS/1340	TPE01*FS/1340	TPI01*FS/1340
TPE01*WS/1430	TPI01*WS/1430	TPE01*FS/1430	TPI01*FS/1430

*N= Natural Gas or P= Propane

Flue components are available for indoor installations. Please contact Rheem or see Owner's Guide and installations, available at www.rheem.com.au

RHEEM TANKPAK® Series

Single Unit – Tankpak 1

TANKPAK 1 MODEL	INTERNAL EXTERNAL	TPIO1 TPE01
Thermal Input	MJ/h	205
Recovery Rate at 50°C rise	L/hr	825
1 st Hour Capacity (325L)	Litres	1150
1 st Hour Capacity (410L)	Litres	1230
Mounting Options		Tank / Wall
Storage Tanks		1x 610340 1x 610430
Electrical Supply (240V/50Hz)	Amps	0.75 per CFWH
Pump Start Current	Amps	1.0 per Pump
Electrical Connection		1.8m 10A Plug & Lead per CFWH 1.8m 10A Plug & Lead per Pump C Controller
PHWF & PHWR Pipe Size	mm	25
Natural Gas Pipe Size	mm	20
Propane Gas Pipe Size	mm	20
Weight Empty (incl. Tank, CFWH, pump & Controller)	kg	150
Delivery Temperature	°C	Up to 82

CFWH Dimensions



RHEEM COMMERCIAL CONTINUOUS FLOW		EXTERNAL MODEL	INTERNAL MODEL
Height	mm	600	650
Width	mm	350	350
Depth	mm	225	250

Storage Tanks Dimensional Drawing

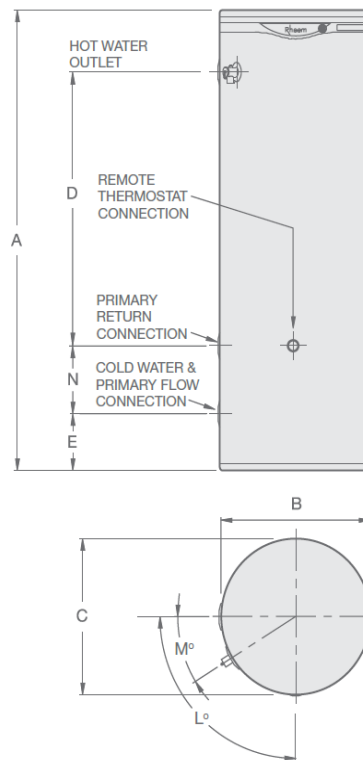

Model number		610 340	610 430
		vitreous enamel	
Storage capacity	Litres	325	410
Dimensions	A	mm	1640
	B	mm	640
	C	mm	640
	D	mm	1008
	E	mm	115
	F	mm	-
	G	mm	-
	H	mm	-
	J	mm	290
	K	degrees	-
	L	degrees	90°
	M	degrees	32°
	N	mm	290
Weight Empty	kg	96	117

Recommended TANKPAK Settings

PRODUCT	SET POINT	DIFFERENTIAL
CFWH	70°C	-
Controller	65°C	3
Pump Speed	3	-

610 Series