



COMMERCIAL &
INDUSTRIAL PRODUCTS

HIGH-VOLUME HOT WATER SOLUTIONS

 **80**
YEARS LOCAL
MANUFACTURING

Trust in the reliability, safety and performance of Australia's broadest range of robust, hot water products, backed by exceptional technical expertise.

TRUST IN RHEEM, THE PREMIER COMMERCIAL WATER HEATER COMPANY IN AUSTRALIA.

Our reputation is built on the trust we have developed with specifiers, installers and users over 45 years servicing the commercial water heating industry.

- Trust in our Australian Research and Development excellence
- Trust in the robustness and reliability of our commercial products
- Trust in the professionalism and expert knowledge of our Service Technicians
- Trust that Rheem has a solution for almost every conceivable design requirement

Rheem has the biggest range of water heaters available in the market. If you're sizing, designing, installing, commissioning or servicing a commercial hot water plant, we can assist you.

Rheem has the know-how to help you put it all together, coupled with an unequalled network of experienced, factory-trained Rheem Service Technicians for after sales support.

We are here to help. Call us today.



As a Rheem Technician I am trained to know our products from the inside out, and our monthly in-house training program ensures we have the highest knowledge base in the industry.

David Hoppe, Rheem Technician

CONTENTS

Interactive 

01	RHEEM CONNECT® BMS AND REMOTE MONITORING	4
02	CONTINUOUS FLOW HOT WATER TANKPAK SERIES 3	8
03	HEAVY DUTY STORAGE GAS	28
04	RAYPAK® HEATING AND HOT WATER MODULATING VERTICAL BURNER (MVB)	36
05	HEAVY DUTY ELECTRIC	52
06	COMMERCIAL HEAT PUMP	58
07	HEAT EXCHANGER TECHNOLOGY	68
08	GUARDIAN WARM WATER	74
09	STORAGE TANKS	77
10	BOILING WATER	82
11	COMMERCIAL SOLAR	89
12	PUMP ACCESSORIES	95
13	SIZING GUIDE	99

RHEEM CONNECT® BMS AND REMOTE MONITORING

Commercial hot water systems are made up of a variety of components such as primary water heating plant, storage tanks, building return pumps and centralised tempering.

Rheem Connect® brings all of these elements together into a neat packaged solution for monitoring the system performance in new or retrofit applications.

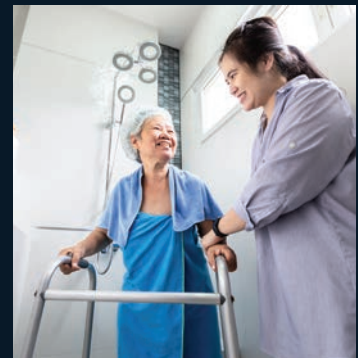

RHEEM CONNECT® BMS AND REMOTE MONITORING

HIGH LEVEL BMS (HLI) AND/OR REMOTE MONITORING WITH PRIORITY SERVICE



BMS CONNECTIVITY



REMOTE MONITORING



EASY TO MAINTAIN



PRIORITY SERVICE

PEACE OF MIND

Rheem Connect® provides peace of mind by monitoring the hot water system and providing data and alarms to either on site BMS, remote customer monitoring via dashboard or downloadable link on mobile or remote monitoring by Rheem. As part of a total service offering, Rheem Monitoring by Rheem also provides scheduled maintenance and priority service levels.

INCREASED RELIABILITY

Regular maintenance is a proven means of maintaining optimum performance and efficiency and extending product life. Tankpak Series 3 Deluxe model monitors up to 30 Continuous Flow Water Heater (CFWH) inputs and up to 14 system inputs.

MONITOR WARM WATER SYSTEMS

All jurisdictions have particular requirements for centralised warm water systems. Rheem are the hot water experts, and a Rheem monitored warm water system provides peace of mind in being able to monitor important system parameters and validate maintenance regimes, whilst providing documented records of system performance and historical maintenance in conjunction with a Rheem Service Contract.

WHAT'S MONITORED?

Depending on system, the following points are monitored:

- Tank temperature
- Hot and warm water supply temperature to building
- Hot or warm water return temperature
- Primary and secondary pump operation
- Up to 32 individual alarms



*Conditions Apply: For full terms and conditions please contact Rheem or visit www.rheem.com.au/rheem/help/Warranties

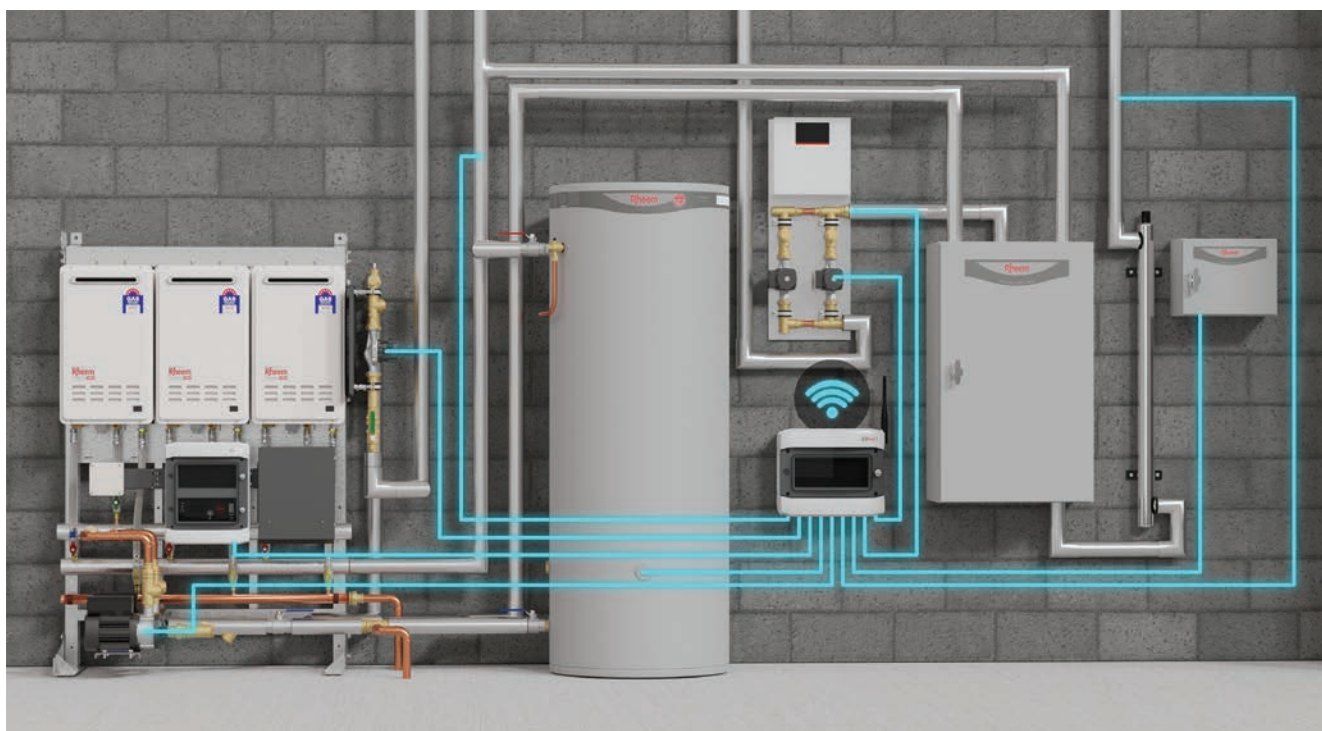



RHEEM CONNECT[®] PACKAGES

BMS PACKAGE

Enables local BMS capabilities to monitor from site via Ethernet through Rheem Connect[®]. BMS options include Modbus/TCP on Ethernet and BACnet/TCP on Ethernet.

CLOUD PACKAGE

Enables local and/or remote monitoring for customers via cloud service.

PREMIUM PACKAGE

24/7 remote monitoring by Rheem and Rheem can manage service issues with or without a Service Agreement.



MONITORED SYSTEMS

Rheem Connect[®] is available on the following Rheem products:

- Tankpak Series 1, Series 2 and Series 3 Standard as a new or retrofit package including Deluxe Rediset pump sets
- Tankpak Series 3 Deluxe, including factory integrated building circulators, as a new installation or retrofit package
- Guardian Warm Water and UV with any Tankpak and Deluxe Rediset pump set

MONITORING OPTIONS

Monitoring Options include:

- Local BMS via Ethernet
- Remote customer monitoring of all connected sites via cloud service
- Remote monitoring by Rheem, with or without a service agreement or a combination of all of the above
- Remote monitoring can be via building LAN or 4G modem (SIM card included)
- Customer monitoring is also available on Rheem Connect[®] via a downloadable link which provides up to date information no matter where you are



RHEEM SERVICE

Rheem Service Agreements in conjunction with Rheem Connect® monitoring package provides optimum value. Rheem monitors systems 24/7 and, with a national in-house service network, can rectify any issues before they become problematic. Routine service is linked to the monitored system and service levels can be tailored to suit system performance rather than being

on a fixed time basis. This keeps you and your customers in hot water whilst keeping service costs under control.

PACKAGE INCLUSIONS

- 1 x site visit to establish system requirements
- Supply of monitoring kit including temperature sensors and pump CT sensor (where applicable)
- Installation including connection to all monitored equipment, documentation and activation and liaison with BMS configurator. Custom integration is outside of scope, but is available on request
- Log in to Rheem Connect® (if remote monitoring is included in package)

TECHNICAL SPECIFICATIONS

	Part Number	TPS3 Dlx	TPS1, S2, S3 Std	TPS1, S2, S3 Std + Rediset Dlx	TPS1, S2, S3 Std + Rediset Dlx + Guardian	TPS3 Dlx + Rediset Dlx + Guardian
Rheem Connect Gateway ¹	299319	Y				
Rheem Connect Plus Gateway ²	299320		Y	Y	Y	Y
4G Modem Telstra	299884	Optional on all systems if Ethernet connection not available				
Electrical Connection	Supplied with 1.8m 10Amp 3 pin plug and flex					

¹ Includes 1.5m and 10m LAN cables

² Includes 1.5m and 10m LAN cables, 4 x 10m temperature sensors, 1 x sensor well 1/2" x 200mm long, pump CT harness

CONTINUOUS FLOW HOT WATER

6-star energy efficiency, mains pressure delivery, space and energy saving options.

Factory-tested, pre-assembled, and delivered as a complete package.



CASE STUDY

OAKWOOD PREMIER MELBOURNE SOUTHBANK, VIC

Challenge

Oakwood Premier Melbourne is set within a 40-storey tower boasting 132 luxurious hotel rooms and 260 serviced apartments, co-working space, fitness centre, game room, restaurant and bars.

The introduction of the electronic staging and rotation on the Tankpak Series 3 model

was essential for satisfying the energy saving requirements. A long history of partnership with both ADP Consulting and Complete Plumbing led to a successful solution design and implementation.

Hot Water Solution

Servicing a maximum first hour capacity of 13,985 L and providing 12,345 L/hour recovery, the final installation included 3 x TP3E05NFD/1430 Tankpak Series 3 Systems with 3 x Rheem 610430 Storage tanks.



CONTINUOUS FLOW HOT WATER

FOR CONTINUOUS HOT WATER FLOW IN HIGH DEMAND ENVIRONMENTS



GAS



RATING



CONSTANT TEMP



FROST PROTECTION



FAULT PROTECTION

The continuous flow water heater with 6-star energy efficiency.

HIGH ENERGY EFFICIENCY

6-star energy rating and 84% thermal efficiency

CONSTANT TEMPERATURE

Q-factor® provides constant temperature at the outlet rapidly reducing 'cold water sandwich'

COMPATIBLE WITH OTHER SYSTEMS

Compatible with solar, heat pump and waste heat systems. EZ Link® two units together with a greater capacity and redundancy

FAULT PROTECTION

Unique Flame Safe® technology detects heat exchanger faults and shuts the system down

MORE KEY FEATURES

- Digital temperature display (Tankpak, Commpak and Commpak Plus)
- Internal and external models available
- Natural gas and propane models
- Frost protection
- Suitable for sanitising applications when set at 82°C



External Model

Internal Model



*5 year warranty on heat exchanger with a thermostat setting not exceeding 75°C; 12 months heat exchanger warranty when used with a thermostat setting exceeding 75°C.



*Conditions Apply: For full terms and conditions please contact Rheem or visit www.rheem.com.au/rheem/help/Warranties

TECHNICAL DATA

RHEEM COMMERCIAL CONTINUOUS FLOW		EXTERNAL MODEL	INTERNAL MODEL
MODEL		872627	862627
Delivery Temperature	°C	Up to 82	Up to 82
Input	MJ/h	205	205
Output	kW	46.5	46.5
Efficiency	%	84	84
Gas Energy Rating	Stars	6	6
Flow Rate @ 25°C Rise	L/min	27	27
Minimum Flow Rate	L/min	2	2
Dimensions			
Height	mm	600	650
Width	mm	350	350
Depth	mm	225	250
Frost Protection		yes	yes
Approximate Weight	kg	24	27
Inlet/Outlet Connections	BSPM	R ³ / ₄ /20	R ³ / ₄ /20
Gas Connection	BSPM	R ³ / ₄ /20	R ³ / ₄ /20
Water Supply Pressure			
Maximum	kPa	1000	1000
Minimum	kPa	140	140
Gas Supply Pressure Range			
Natural Gas	kPa	1.13 – 3.5	1.13 – 3.5
Propane	kPa	2.75 – 3.5	2.75 – 3.5
Temperature Settings	°C	38, 40, 42, 43, 45, 50, 55, 60, 65, 70, 75, 82	38, 40, 42, 43, 45, 50, 55, 60, 65, 70, 75, 82
Factory Set Temperature	°C	60	60
Co-Axial Flue Specification			
Inner – Material/Diameter	mm	NA	316L or 444/78
Outer – Material/Diameter	mm	NA	Aluminised Steel/127
Maximum Flue Run		NA	13.5m and no bends ¹
Accessories			
Pipe Cover		299425	NA
Recess Box		299831	NA
Security Bracket		299868	299868
Security Cage		299867	NA
Gas Booster Mounting Kit (suit TP01)		299100	29100
EZ Link® Kit		299291	299291
Temperature Controllers (Max 60°C)			
Kitchen		299850	299850
Bathroom 1		299851	299851
Bathroom 2		299852	299852

¹Reduce the maximum length by 1.5m for every 90° elbow and by 0.75m for every 45° elbow. The flue system is suitable for through the roof and through the wall termination when used with the appropriate terminal.

TANKPAK® SERIES 3 STANDARD

BUDGET ALTERNATIVE FOR SMALLER COMMERCIAL APPLICATIONS



GAS



2 TO 6 PAK



NO FRILLS



STAGE & ROTATE



MEETS PEAK DEMAND

Top down heating for faster hot water delivery and better redundancy.

ELECTRONIC STAGING AND ROTATION

Continuous flow gas water heater (CFGWH) stage¹ as demand increases, reducing energy and extending life by only using the heaters required to meet the demand. Rotation to the next heater occurs on each new call for heat or if the status of a heater becomes 'unavailable' during operation.

LED Power/Run/Error indicator with flash codes monitors all aspects of the system for faster servicing.

Warning alarm initiated should water heater filters become blocked so servicing can be scheduled before any loss of system performance.

LIGHTER, SHORTER FRAMES

New frame design is shorter and lighter. New specific 2 bay frame reduces smallest unit width by 360mm and 8kg.

Certified for lifting, and wind rated.

REDUCED INSTALLATION COSTS

Indoor models are supplied with factory fitted common condensate drains and trap for surety and reduced installation costs.

Water heater GPOs are provided as standard.

10Amp plug and lead for all models for a 1 trade install.



*Conditions Apply: For full terms and conditions please contact Rheem or visit www.rheem.com.au/rheem/help/Warranties

TANKPAK® SERIES 3 DELUXE

FOR WHEN THE SPECIFICATION DEMANDS THE BEST



GAS



2 TO 18 PAK



STAGE & ROTATE



INTELLIGENT CONTROLLER



BMS & REMOTE MONITORING



DUTY STANDBY PUMPS

Redundancy features and pump options and remote monitoring by Rheem increase system reliability.

STAGE/ROTATE WITH INTELLIGENT CONTROLLER

Full access to all operational parameters and alarms is made possible via the new smart controller, on board and via Rheem Connect for BMS and/or remote monitoring by Rheem for total peace of mind.

Continuous flow gas water heater (CFGWH) stage¹ as demand increases, reducing energy and extending life by only using the heaters required to meet the demand. Rotation to the next heater occurs on each new call for heat or if a heater is off line.

SYSTEM DIAGNOSTICS WITH MULTIPLE SENSORS

Three sensors monitor tank, building flow and building return temperatures for total system diagnostics.

36 individual alarm points monitored, including blocked filter warning so servicing can be initiated before any loss of system performance.

DUTY/STANDBY PUMP OPTIONS

Optional duty/standby primary and/or secondary pumps supplied on the frame² saving plant room space and installation costs.

Auto duty changeover or if a pump is in error provides 100% redundancy.

Secondary pumps cycle on temperature to reduce building energy consumption.

LIGHTER, SHORTER FRAMES

New frame design is shorter and lighter. New specific two bay frame reduces smallest unit width by 360mm and 8kg.

Certified for lifting, and wind rated.

Indoor models are supplied with factory fitted common condensate drains and traps for surety and reduced installation costs.

New high efficiency Grundfos UPM series secondary pumps provide greater control of required flow rate for better velocity control.

CM3-2 secondary pump option is supplied pre-plumbed but separate to the frame.

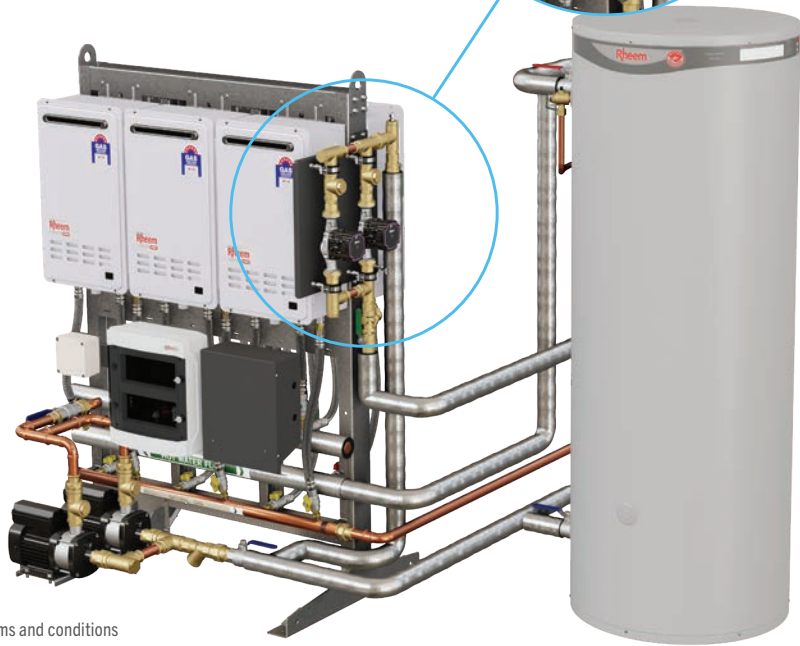

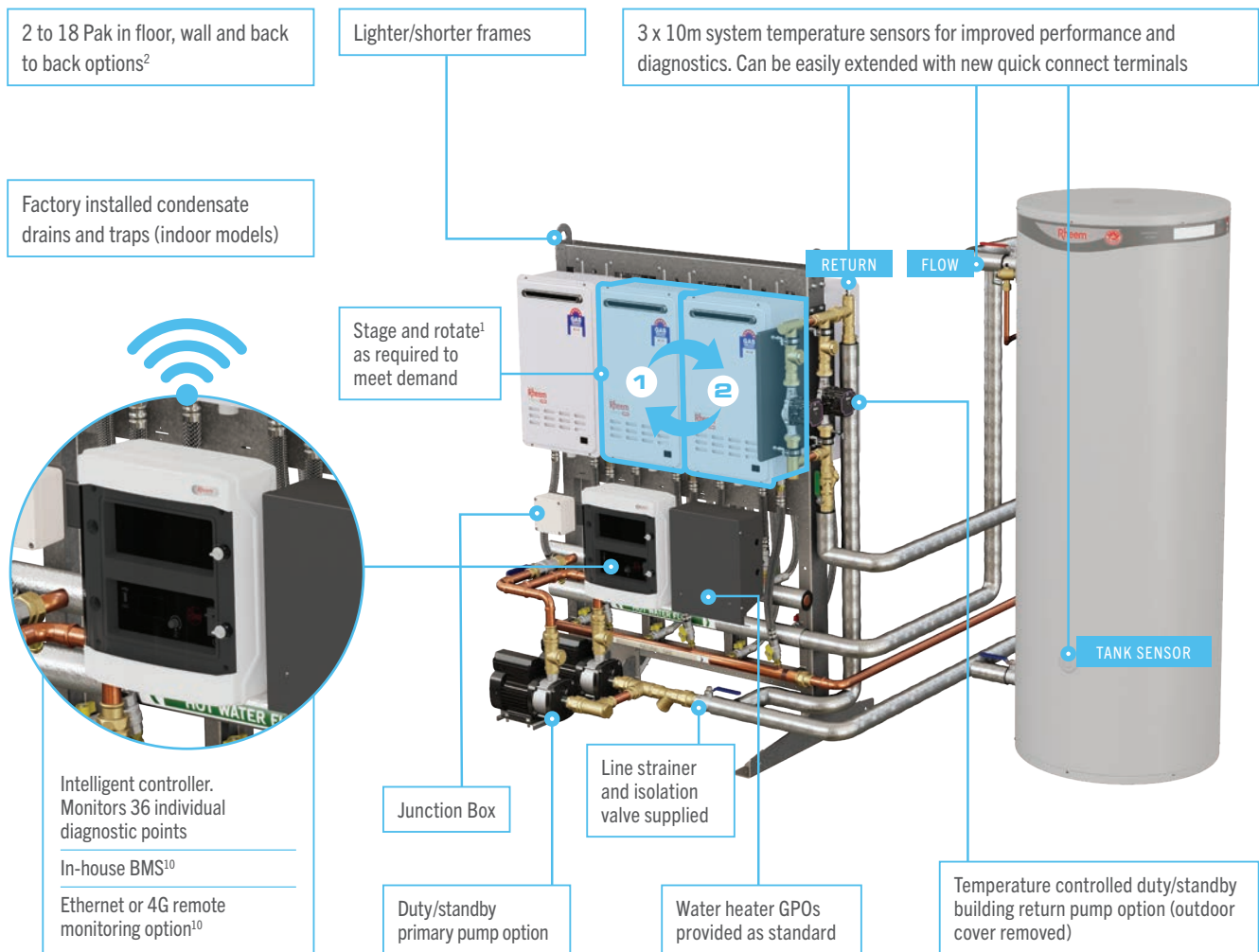

*Conditions Apply: For full terms and conditions please contact Rheem or visit www.rheem.com.au/rheem/help/Warranties

TANKPAK® SERIES 3 DELUXE FEATURES UP CLOSE

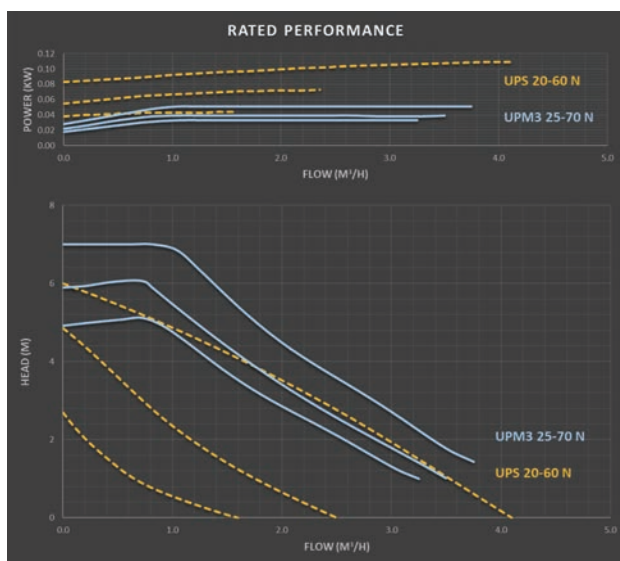

**New UPM 3 25-70 and UPS 20-60
Secondary Pump Comparison Curves**



**New UPM XL 25-125 and UPS 32-80
Secondary Pump Comparison Curves**



STANDARD MODEL CONTROLLER WITH ONE PRIMARY PUMP

WIDTH					
No. of Heaters	2	3	4	5	6
Inline (mm)	755	1118	1481	1844	2207
Back to Back (mm)	-	-	755	1118	1118

*All dimensions are reference only.

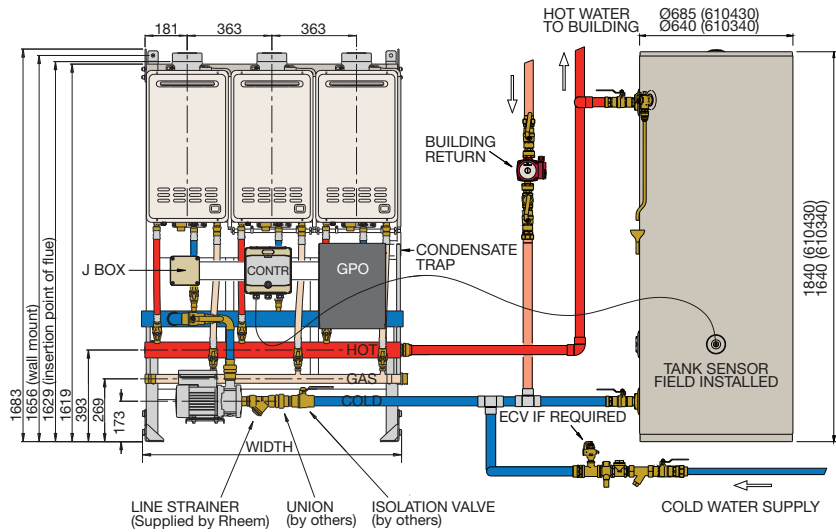

Front View

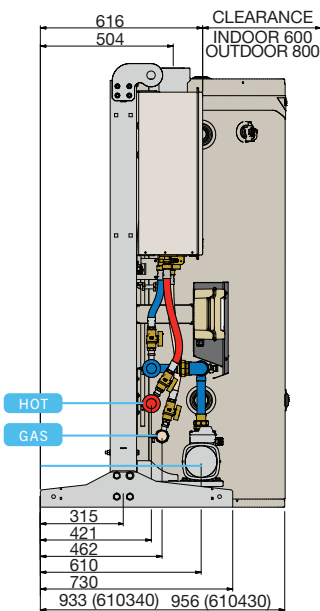

Floor Mount

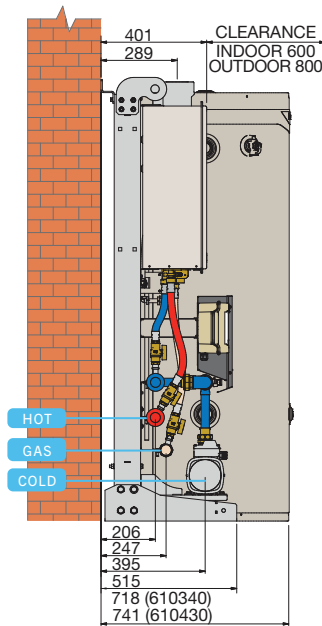

Wall Mount

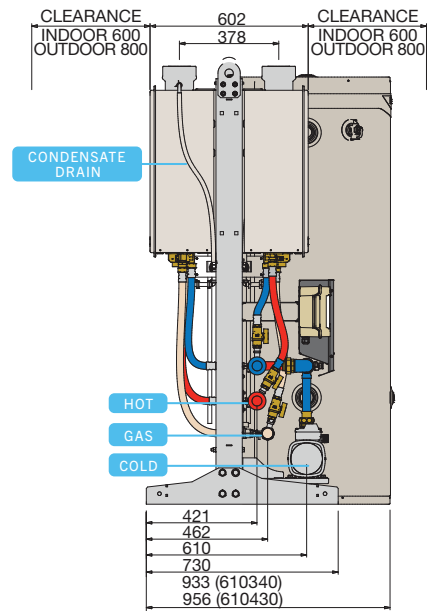

Back To Back

DELUXE MODEL CONTROLLER WITH TWO PRIMARY PUMPS AND TWO SECONDARY PUMPS

WIDTH							
No. of Heaters	2	3	4	5	6	7	8
Inline (mm)	755	1118	1481	1844	2207	2570	2933
Back to Back (mm)	-	-	755	1118	1118	1481	1481

WIDTH						
No. of Heaters	9	10	12	14	16	18
Inline (mm)	3296	-	-	-	-	-
Back to Back (mm)	1844	1844	2207	2570	2933	3296

*All dimensions are reference only.

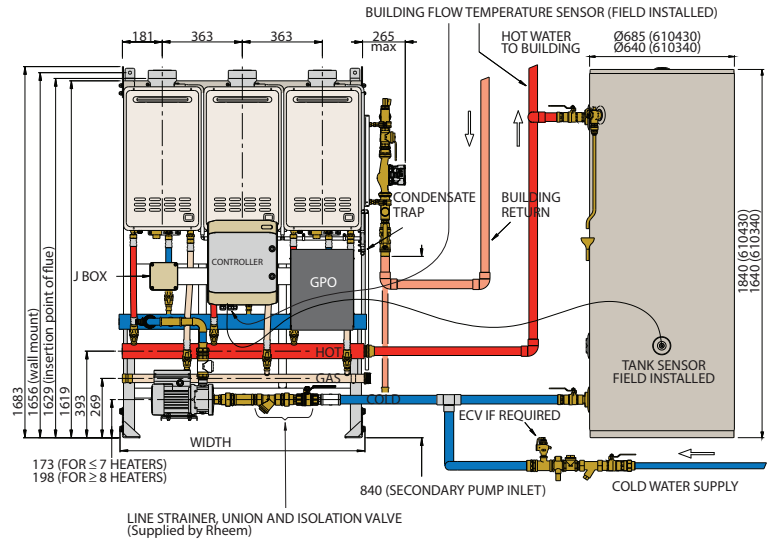

Front View

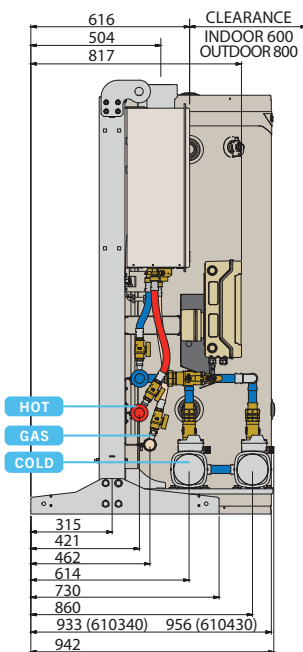

Floor Mount

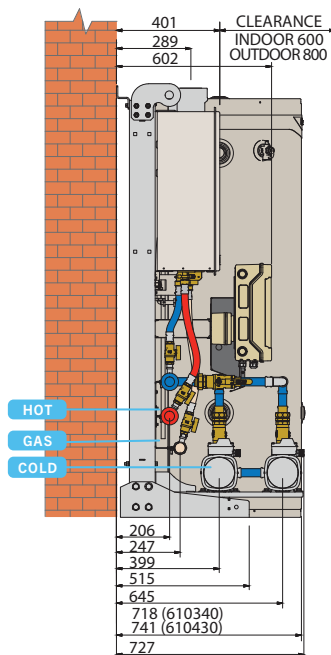

Wall Mount

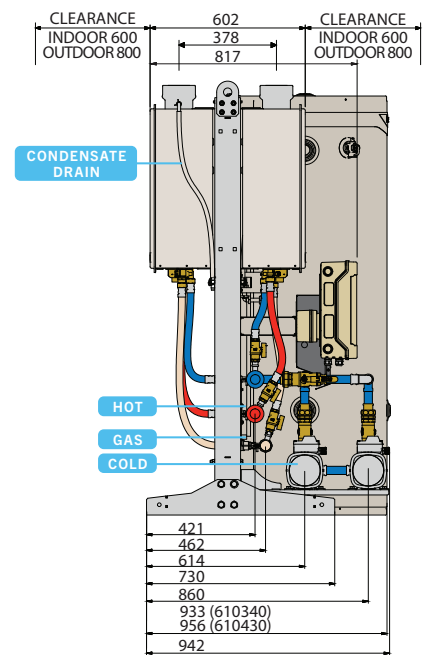

Back To Back

TECHNICAL DATA

TANKPAK								
MODEL	INTERNAL EXTERNAL	TPI 01 ⁴ TPE 01 ⁴	TPI 02 TPE 02	TPI 03 TPE 03	TPI 04 TPE 04	TPI 05 TPE 05	TPI 06 TPE 06	
Thermal Input	MJ/h	205	410	615	820	1025	1230	
Recovery Rate at 50°C rise	L/hr	825	1645	2470	3290	4115	4935	
Mounting options		W/F ⁴	W/F	W/F	W/F/B	W/F/B	W/F/B	
Standard or Deluxe			Standard or Deluxe					
Storage Tanks		1 x 610340	1 x 610340	1 x 610340	1 x 610340	-	-	
		1 x 610430	1 x 610430	1 x 610430	1 x 610430	1 x 610430	1 x 610430	
1st Hour Capacity (610340)	Litres	1150	1970	2795	3615	-	-	
1st Hour Capacity (610430)	Litres	1230	2055	2880	3700	4525	5345	
Electrical Supply 240V 50Hz (STD/DLX) ⁵	Amps	0.75	5.1/7.5	5.9/8.3	6.7/9.2	7.9/10.7	8.8/11.5	
Electrical Connection	STD	1.8m 10A plug and lead						
Electrical Connection	DLX	1.8m 10A plug and lead				240V 50Hz single phase hard wired connection		
PHWF and PHWR Pipe Size	mm	25	25	32	40	40	40	
Gas Connection – Inline	mm	20	40	40	40	50	50	
Gas Connection – Back to Back	mm	-	-	-	40	40	40	
Weight Empty (F/B) ³	STD	kg	150	251	288	326/306	390/346	427/370
Weight Empty (F/B) ³	DLX	kg	-	305	342	380/360	444/400	481/424

PUMP IDENTIFICATION	PUMP MODEL	PRIMARY PUMP	PRIMARY PUMP OPTIONS	SECONDARY PUMP OPTIONS
1	CM3-2	(2 to 4 Pak)	Single pump (STD & DLX) or Duty/Standby (DLX only)	Optional Duty/Standby Skid supplied separately (5-18 Deluxe only) P/No AQ33116044
2	CM5-2	(5 to 7 Pak)		NA
3	CM10-1	(8 to 18 Pak)		NA
4	UPM3 (UPS 20-60N equivalent)			Optional Duty/Standby supplied on frame (Deluxe only)
5	UPMXL (UPS32-80N equivalent)			

PRODUCT CODE IDENTIFICATION										
Tankpak Series 3	External or Internal	No. of Heaters	Natural Gas Or Propane	Back To Back/ Floor/ Wall	Standard or Deluxe	No. of Primary Pumps	Primary Pump Model	Heater ID	No. of Secondary Pumps	Secondary Model
TP3	E	02-06 (STD)	N	B (04-18)	S (02-06)	1 (STD/DLX)	1 (02-04)	8	0 (STD/DLX)	0 (NO PUMP)
		02-18 (DLX)	P	F (02-09)	D (02-18)	2 (DLX ONLY)	2 (05-07)		2 (DLX ONLY)	4 (UPM3)
			W (02-09)			3 (08-18)			5 (UPMXL)	
									1 (CM3-2)	

DELUXE PRODUCT CODE EXAMPLE TP3E10NBD22824

TP3 (Tankpak Series 3) + E (External) + 10 (Number of Heaters) + N (Natural gas) + B (Back to Back) + D (Deluxe) + 2 (Number of Primary Pumps) + Pump Model Identifier + 8 (Heater Identification) + 2 (Number of Secondary Pumps) + Pump Model Identifier.

STANDARD PRODUCT CODE EXAMPLE TP3I06PWS12800

TP3 (Tankpak Series 3) + I (Internal) + 6 (Number of Heaters) + P (Propane) + W (Wall Mount) + S (Standard) + 1 (1x Primary Pump only) + Pump Model Identifier + 8 (Heater Identification) + 00 (No Secondary Pumps supplied on Pak).

TECHNICAL DATA

TANKPAK									
MODEL	INTERNAL EXTERNAL	TPI 07 TPE 07	TPI 08 TPE 08	TPI 09 TPE 09	TPI 10 TPE 10	TPI 12 TPE 12	TPI 14 TPE 14	TPI 16 TPE 16	TPI 18 TPE 18
Thermal Input	MJ/h	1435	1640	1845	2050	2460	2870	3280	3690
Recovery Rate at 50°C rise	L/hr	5760	6580	7405	8225	9875	11520	13165	14810
Mounting options	W/F/B	W/F/B	W/F/B	W/F/B	B	B	B	B	B
Deluxe or Standard	Deluxe								
Storage Tanks		-	-	-	-	-	-	-	-
		1 x 610430	2 x 610430	2 x 610430	2 x 610430	2 x 610430	3 x 610430	3 x 610430	3 x 610430
1st Hour Capacity (610340)	Litres	-	-	-	-	-	-	-	-
1st Hour Capacity (610430)		6170	7400	8225	9045	10695	12750	14395	16040
Electrical Supply (240V/50Hz)	Amps	12.4	14.5	15.3	16.1	17.8	19.5	21.1	22.7
Electrical Connection	STD	-							
Electrical Connection	DLX	240V 50Hz single phase hard wired connection							
PHWF and PHWR Pipe Size	mm	50	50	50	50	50	65	65	65
Gas Connection – Inline	mm	50	50	50	-	-	-	-	-
Gas Connection – Back to Back	mm	50	50	65	65	65	65	65	80
Weight Empty (F/B) ³	STD	kg	-	-	-	-	-	-	-
Weight Empty (F/B) ³	DLX	kg	527/476	702/633	766/701	725	907	981	1047

TANKPAK QUICK SIZING GUIDE											
Apartments 1 hr peak				Hotel Rooms 1 hr peak	Amenities 30 min peak	Nursing home 2 hr peak	Tankpak Series 3 Model	Recovery @ 50°C Rise (L/hr)	Storage Tank Capacity (L)	First Hour Capacity (L)	Thermal Input (MJ/h)
Studio ⁶	1 & 2 bedroom ⁶	2 bedroom ⁶	2 & 3 bedroom ⁶	1-3 Star ⁷	No. of showers ⁸	No. of beds ⁹					
49	21	16	14	24	32	30	TP01/1430	825	410	1235	205
82	35	27	24	41	49	54	TP02/1430	1645	410	2055	410
115	50	38	34	57	65	79	TP03/1430	2470	410	2880	615
148	64	49	44	74	82	103	TP04/1430	3290	410	3700	820
181	78	60	54	90	98	128	TP05/1430	4115	410	4525	1025
213	92	71	64	106	115	152	TP06/1430	4935	410	5348	1230
246	107	82	74	123	131	176	TP07/1430	5760	410	6170	1435
296	128	98	89	148	164	207	TP08/2430	6580	820	7400	1640
329	143	109	99	164	180	231	TP09/2430	7405	820	8225	1845
361	157	120	109	180	197	255	TP10/2430	8225	820	9045	2050
427	186	142	129	213	230	304	TP12/2430	9875	820	10695	2460
510	221	170	154	255	279	359	TP14/3430	11520	1230	12750	2870
575	250	191	174	287	312	408	TP16/3430	13165	1230	14395	3280
641	278	213	194	320	345	457	TP18/3430	14810	1230	16040	3690

¹ 2 Pak does not stage.

² Model dependent.

³ Weight includes CFWH unit, 610430 storage tank/s, 1 x primary pump, frame and preassembled manifolds. Note: Add 48.2kg for CM3-2 and CM5-2 D/S Primary assy, 63.8kg for CM10-1 D/S primary assy, 19.4 kg for UPM3 D/S secondary assy and 22.7 kg for UPMXL D/S secondary assy.

⁴ Tankpak models with 1x CFWH are supplied with CFWH, pump and controller separately. The CFWH must be mounted on a vertical wall(W) or use Tank Mounting Bracket 299100(F).

⁵ DLX models based on all heaters, 1 x primary pump and 2 x UPMXL operating simultaneously.

⁶ Allowance - Studio 25L, 1 bedroom 40L, 2 bedroom 75L, 3 bedroom 90L. Calculated on even ratio of apartment mix.

⁷ Allowance - 2 people per room, 25L per person.

⁸ Allowance - 25L per shower.

⁹ Allowance - 37.5L per bed for showering, bed pans, cleaning, 6L per bed for meals, 24L per bed for laundry.

¹⁰ Via Rheem Connect monitoring package.

MULTIPAK[®]

FOR CARAVAN PARKS, SMALL STADIUMS AND SPORTS FACILITIES



GAS



RATING



FAST INSTALLATION



MEETS PEAK DEMAND

The staged ignition hot water system that meets intermittent high demand.

MEETS HIGH DEMAND WHEN NEEDED

Staged ignition system allows large but intermittent hot water demands as well as small demands to be met easily, without maintaining heating during unused periods.

FAST AND EFFICIENT TO INSTALL

Rheem factory-tests each order before supplying the entire CFWH system, so there are no delays on site.

TEMPERING

In 60°C temperature mode, suitable for use in dead leg and recirculation systems with tempering. In 50°C mode, suitable for use without the need for external tempering devices for dead leg applications only.¹

MORE KEY FEATURES

- Natural gas and propane models
- Left or right hand plumbing
- Wall and floor mount options
- Optional factory fitted secondary hot water circulator available



*Conditions Apply: For full terms and conditions please contact Rheem or visit www.rheem.com.au/rheem/help/Warranties

TECHNICAL DATA

MULTIPAK						
MODEL	INTERNAL EXTERNAL	MPI 02 MPE 02	MPI 03 MPE 03	MPI 04 MPE 04	MPI 05 MPE 05	MPI 06 MPE 06
Input	MJ/h	410	615	820	1,025	1,230
Recovery Rate at 50°C rise	L/hr	1,645	2,470	3,290	4,115	4,935
Maximum Flow Rate at 50°C rise	L/min	27	41	54	68	81
Minimum Flow Rate	L/min	2.0	2.0	2.0	2.0	2.0
Approx Weight	kg	95	120	185	210	235
Wall Mount		standard	standard	standard	standard	standard
Free Standing Frame (FSF)		optional	optional	optional	optional	optional
Electrical Supply (240V/50Hz)	Amps	1.50	2.25	3.0	3.75	4.5
Electrical Connection		1.8m 10A Plug and Lead per CFWH				
Dimensions						
Width	mm	820	1180	1540	1900	2260
Depth (Wall Mount / Free Standing Frame)	mm	360/500	360/500	360/500	360/500	360/500
Frost Protection		Yes	Yes	Yes	Yes	Yes
Accessories - Secondary circulator ²	part number	299658	299658	299658	299658	299658

¹ 50°C limited systems are suitable for dead leg applications only. Further tempering may be required. Consult AS3500.4 for details.

² Secondary hot water circulator option not available on systems set to deliver 50°C

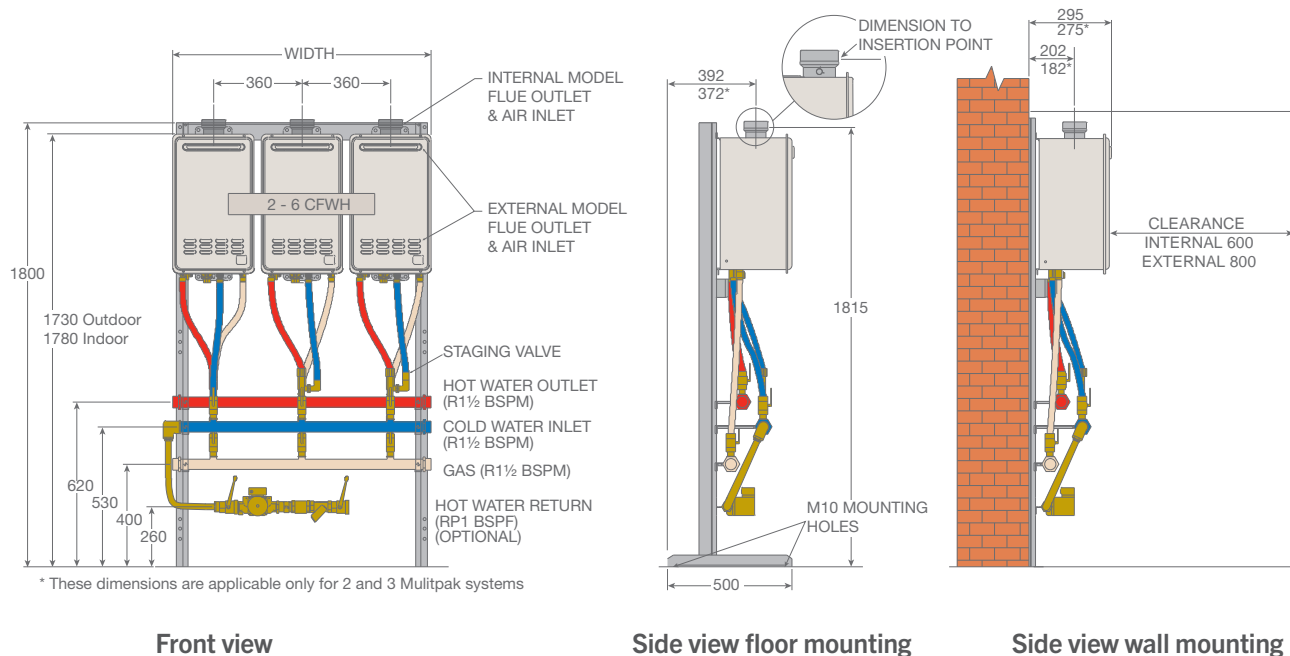

COMMPAK®

FOR SMALL TO MEDIUM
COMMERCIAL APPLICATIONS



NATURAL
GAS ONLY



SMALL
FOOTPRINT



FAST
INSTALLATION



MAINS
PRESSURE

Tankless mains pressure performance.

MAINS PRESSURE HOT WATER IN A SMALL FOOTPRINT

Sophisticated electronics and pump technology equalises hot and cold water pressures, and a differential set point combined with the thermal mass in the system piping replicates storage.

FAST AND EFFICIENT TO INSTALL

Rheem factory-tests each order before supplying the entire CFWH system, including GPOs, pump and controller so there are no delays on site.

BMS CAPABLE

Central control operation with fault monitoring.

MORE KEY FEATURES

- Optional Duty/Standby pumps for additional redundancy
- Install inline up to 6 on one frame
- Loss of prime protection – turns off Commpak system if water pressure is lost



*Conditions Apply: For full terms and conditions please contact Rheem or visit www.rheem.com.au/rheem/help/Warranties

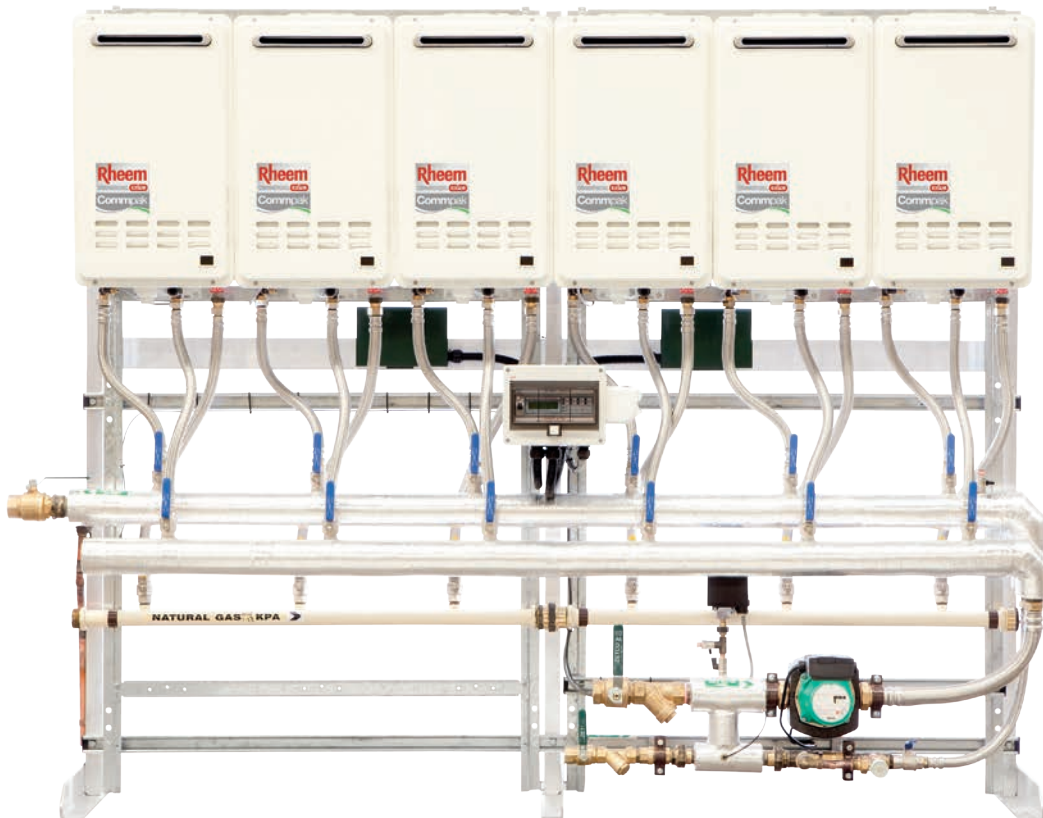

TECHNICAL DATA

COMMPAK						
MODEL	INTERNAL EXTERNAL	CPI 02 CPE 02	CPI 03 CPE 03	CPI 04 CPE 04	CPI 05 CPE 05	CPI 06 CPE 06
Input	MJ/h	410	615	820	1,025	1,230
Recovery Rate at 50°C rise	L/hr	1,645	2,470	3,290	4,115	4,935
Peak Flow Rate at 50°C rise	L/min	27	41	54	68	81
Approx Weight	kg	120	150	220	245	270
Free Standing Frame (FSF)		standard	standard	standard	standard	standard
Electrical Supply (240V/50Hz)	Amps ¹	3.62	4.62	5.62	6.62	7.92
Electrical Connection		Hard Wired	Hard Wired	Hard Wired	Hard Wired	Hard Wired
Dimensions						
Width	mm	1330	1330	1690	2050	2410
Depth (Free Standing Frame)	mm	500	500	500	500	500
Frost Protection		Yes	Yes	Yes	Yes	Yes
Accessories - Duty/Standby pump	part number	299659	299659	299659	299659	299659

¹Single pump. Add 1.62 Amps for Duty/Standby pump option.

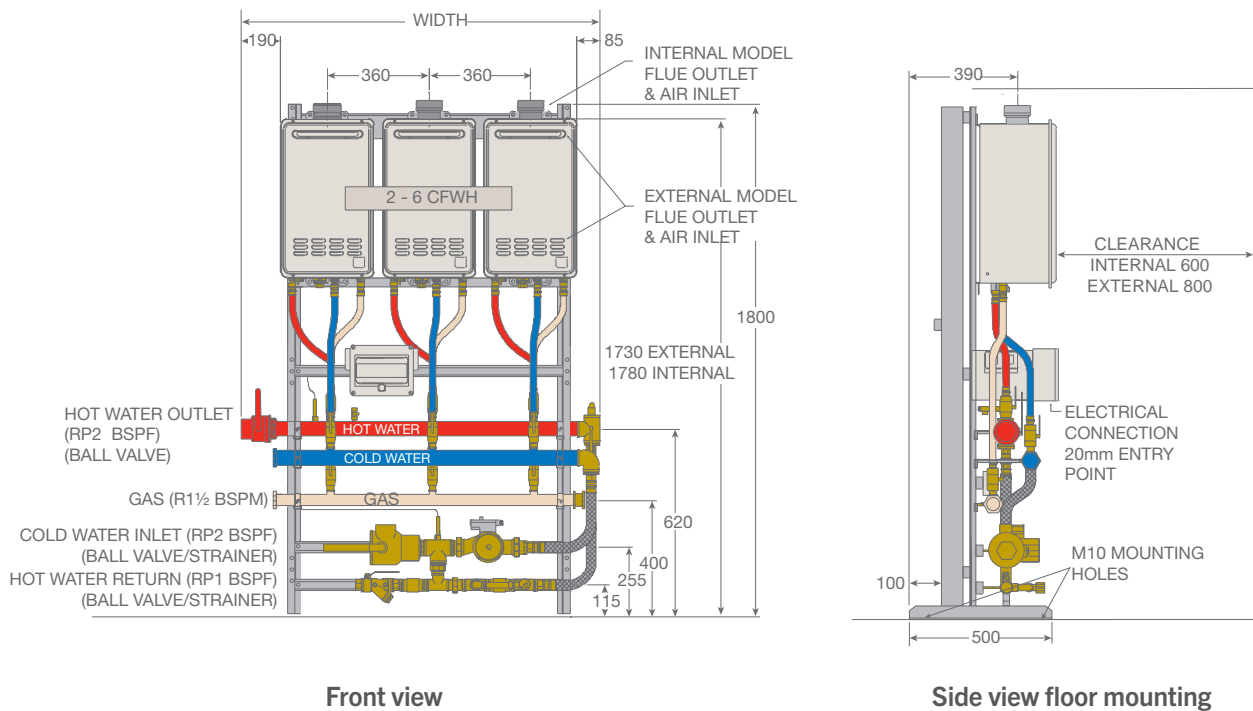

COMMPAK PLUS®

FOR LARGE COMMERCIAL APPLICATIONS



NATURAL GAS ONLY



BUILT-IN REDUNDANCY



SMALL FOOTPRINT



FAST INSTALLATION



MAINS PRESSURE

Staged tankless mains pressure and built-in redundancy, in a small footprint.

BUILT-IN REDUNDANCY AND EXTENDED LIFE

Commpak Plus stages half of the pak with one pump depending on demand extending water heater and pump life.

MAINS PRESSURE HOT WATER IN A SMALL FOOTPRINT

Sophisticated electronics and pump technology equalises hot and cold water pressures and a differential set point combined with the thermal mass in the system piping replicates storage.

FAST AND EFFICIENT TO INSTALL

Rheem factory-tests each order before supplying the entire CFWH system, including GPOs, pump and controller so there are no delays on site.

BMS CAPABLE

Central control operation with fault monitoring.

MORE KEY FEATURES

- Loss of prime protection – turns off Commpak Plus system if water pressure is lost
- In-line or back to back arrangements are available to meet plant room space availability (model dependent)



Inline 7-12 Commpak Plus®

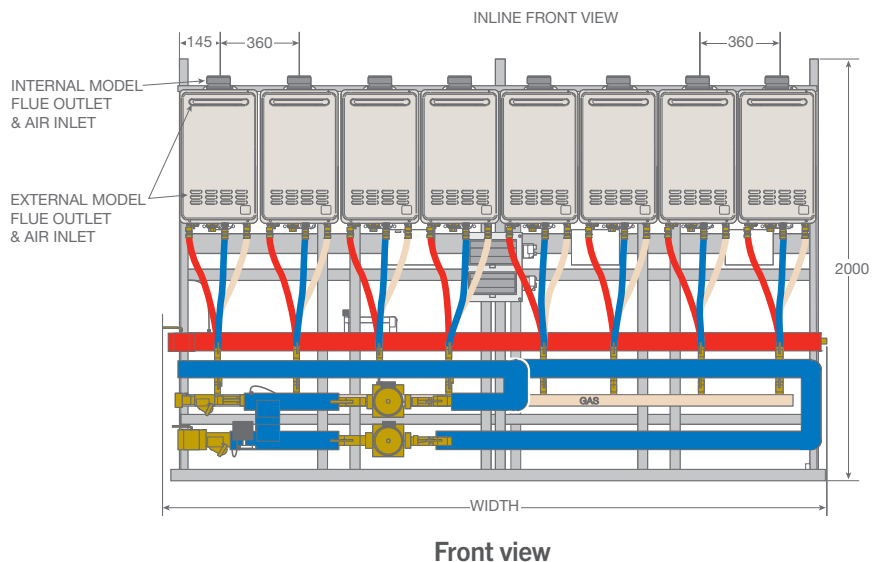

*Conditions Apply: For full terms and conditions please contact Rheem or visit www.rheem.com.au/rheem/help/Warranties

TECHNICAL DATA

COMMPAK PLUS										
MODEL	INTERNAL EXTERNAL	CPI 07 CPE 07	CPI 08 CPE 08	CPI 09 CPE 09	CPI 10 CPE 10	CPI 11 CPE 11	CPI 12 CPE 12	CPI 14 CPE 14	CPI 16 CPE 16	CPI 18 CPE 18
Input	MJ/h	1435	1640	1845	2050	2255	2460	2870	3280	3690
Recovery Rate at 50°C rise	L/hr	5761	6584	7407	8230	9053	9876	11522	13168	14814
Max. Flow Rate at 50°C rise	L/min	96.0	109.6	123.3	137.0	150.7	164.4	191.8	219.2	246.6
Approx Weight	kg	350	380	410	440	470	500	570	640	710
Cold Water/Hot Water										
7-14: Threaded Connection	BSPF	RP2	RP2	RP2	RP2	RP2	RP2	RP2	-	-
16-36: Table E Flanged End	mm	-	-	-	-	-	-	-	65	65
Return	BSPF	RP1	RP1	RP1	RP1	RP1	RP1	RP1½	RP1½	RP1½
Gas	BSPM	R2	R2	R2	R2	R2	R2	R2	R2	R2½
Electrical Supply (240V/50Hz)	Amps	10.24	11.24	12.24	13.24	14.24	15.24	17.24	-	-
Electrical Supply (415V/3 phase/50Hz)	Amps	-	-	-	-	-	-	-	11.0	11.0
Dimensions										
Width - inline	mm	2670	3030	3390	3750	4110	4470	-	-	-
Width - back to back	mm	1980	1980	2340	2340	2700	2700	3310	3670	4030
Frost Protection		Yes	Yes	Yes	Yes	Yes	Yes	Yes	Yes	Yes
Relief Valve Setting	kPa	1000	1000	1000	1000	1000	1000	1000	1000	1000
Water Supply Pressure										
Minimum/Maximum	kPa	140/800	140/800	140/800	140/800	140/800	140/800	140/800	140/800	140/800

Inline 7 -12 Commpak Plus®

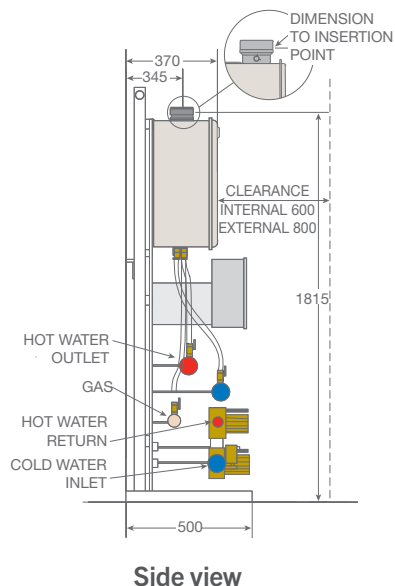

Side view

COMMPAK PLUS										
MODEL	INTERNAL EXTERNAL	CPI 20 CPE 20	CPI 22 CPE 22	CPI 24 CPE 24	CPI 26 CPE 26	CPI 28 CPE 28	CPI 30 CPE 30	CPI 32 CPE 32	CPI 34 CPE 34	CPI 36 CPE 36
Input	MJ/h	4100	4510	4920	5330	5740	6150	6560	6970	7380
Recovery Rate at 50°C rise	L/hr	16460	18106	19752	21398	23044	24690	26336	27982	29628
Max. Flow Rate at 50°C rise	L/min	274.0	301.4	328.8	356.2	383.6	411.0	438.4	465.8	493.2
Approx Weight	kg	780	850	920	990	1060	1130	1200	1270	1340
Cold Water/Hot Water										
7-12: Threaded Connection	BSPF	-	-	-	-	-	-	-	-	-
14-36: Table E Flanged End	mm	65	80	80	80	80	100	100	100	100
Return	BSPF	RP2¼	RP1½	RP1½	RP1½	RP1½	RP2	RP2	RP2	RP2
Gas	BSPM	R2½	R2½	R2½	R2½	R2½	R2½	R2½	R3	R3
Electrical Supply (240V/50Hz)	Amps	-	-	-	-	-	-	-	-	-
Electrical Supply (415V/3 phase/50Hz)	Amps	13.0	14.0	14.0	14.0	15.0	17.0	17.0	17.0	17.0
Dimensions										
Width - inline	mm	-	-	-	-	-	-	-	-	-
Width - back to back	mm	4390	4750	5110	5470	5830	6190	6550	6910	7270
Frost Protection		Yes	Yes	Yes	Yes	Yes	Yes	Yes	Yes	Yes
Relief Valve Setting	kPa	1000	1000	1000	1000	1000	1000	1000	1000	1000
Water Supply Pressure										
Minimum/Maximum	kPa	140/800	140/800	140/800	140/800	140/800	140/800	140/800	140/800	140/800

Back to back 7 - 36 Commpak Plus®

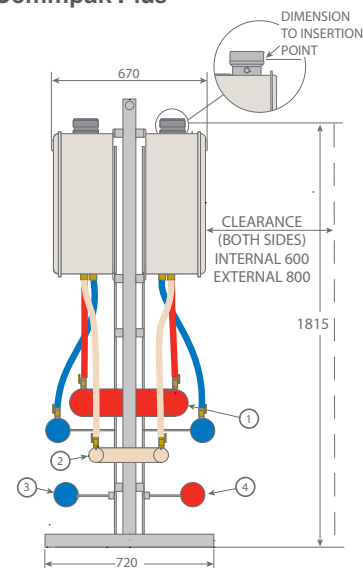

Side view

Back to back 7 - 36 Commpak Plus®

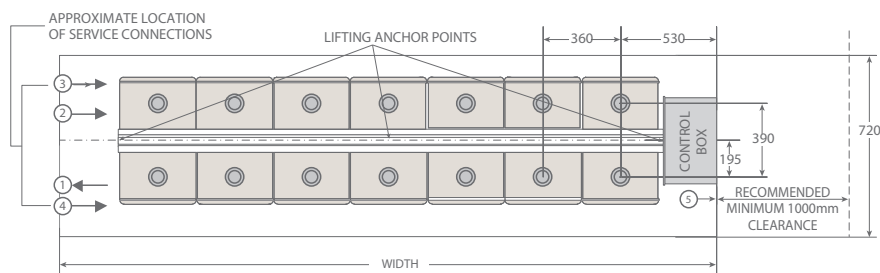

Plan view

- ① HOT WATER OUTLET
- ② GAS
- ③ COLD WATER INLET
- ④ HOT WATER RETURN
- ⑤ PRESSURE RELIEF VALVE OUTLET

CONTINUOUS FLOW FLUE SYSTEM

The Rheem 27 CFWH is available in models suitable for indoor installation. The flue system is room sealed concentric design manufactured from high grade stainless steel inner and aluminised steel outer.

HERE'S A GUIDE TO SELECTING THE FLUE COMPONENTS YOU NEED.

- The overall dimension of each flue piece is shown in the drawings
- Allow approximately 35mm for insertion of each flue piece. Refer to Pak dimensional drawings for height of flue spigot from floor level
- Determine the lineal distance and number of 45° and/or 90° elbows between the top of the water heater and flue terminal. Note, the bottom edge of a vertical flue terminal must be 500mm away from the nearest structure in accordance with AS/NZS 5601.1
- Flashing is required to be installed where a vertical flue section penetrates the roof line (not supplied)
- Separate ventilation for combustion is not required as the air for combustion is supplied in the flue outer
- The flue system is suitable to be installed with zero clearances between the water heaters and combustible materials
- Flue termination must comply with the requirements of AS/NZS 5601.1
- Flue penetrations through walls and ceilings must be sealed in accordance with local fire regulations
- The maximum flue length with no elbows is 13.5m. Reduce the maximum length by 1.5m for every 90° elbow and by 0.75m for every 45° elbow
- The flue system is suitable for through the roof and through the wall installation when used with the appropriate terminal

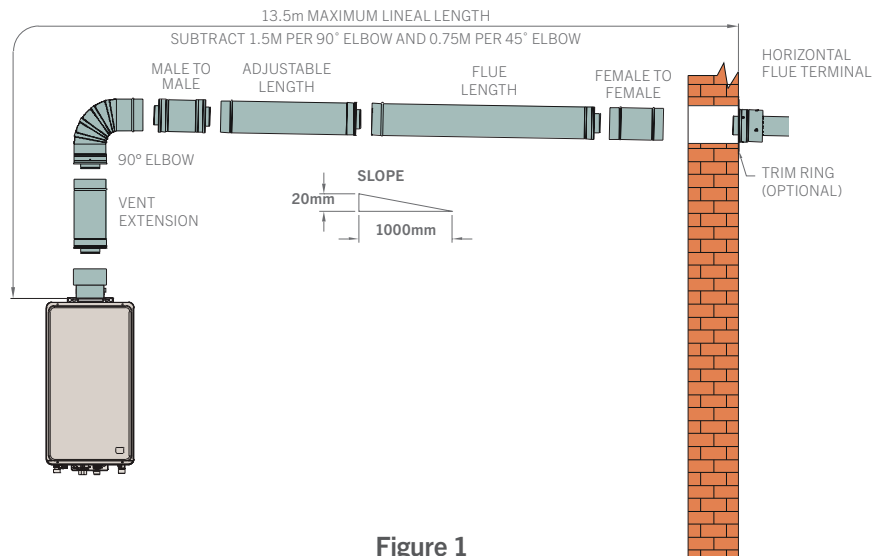

Figure 1

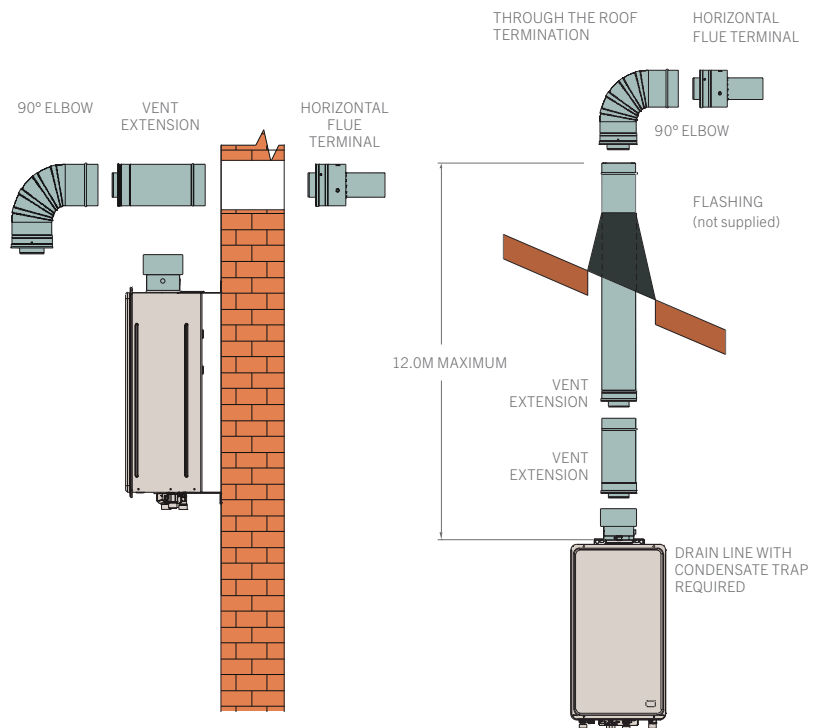

Figure 2

Figure 3



Rheem INTERNAL CFWH must only be installed using certified Rheem coaxial flue components. Do not use any other type of flue system. Carefully follow the installation instructions.

TECHNICAL DATA

CONDENSATE DRAINAGE

- The Flue outlet incorporates a condensate drain which is supplied capped. A condensate tube and trap assembly is supplied with Tankpak and may be required for Commpak and Multipak (sold separately). The condensate drain must be connected to the tube and trap assembly in any through the roof installation to remove any condensate which may form in the flue

- Where 2 x 90° elbows create a vertical section in either through the wall or through the roof flue systems, the horizontal section between the elbows must slope towards the water heater and a condensate tube and trap assembly must be used to prevent condensate from pooling in the horizontal section, see Fig 5
- Horizontal through the wall flue systems are to be oriented with a

slope towards the terminal to drain any condensate which may form in the flue way and prevent any rain from draining into the flue/building. A condensate tube and trap assembly **MUST NOT** be connected, see Fig 4

- Where vertical sections exceeding 2m are incorporated in a through the wall flue system, Condensate tube and trap assembly **MUST** be used, see Fig 4

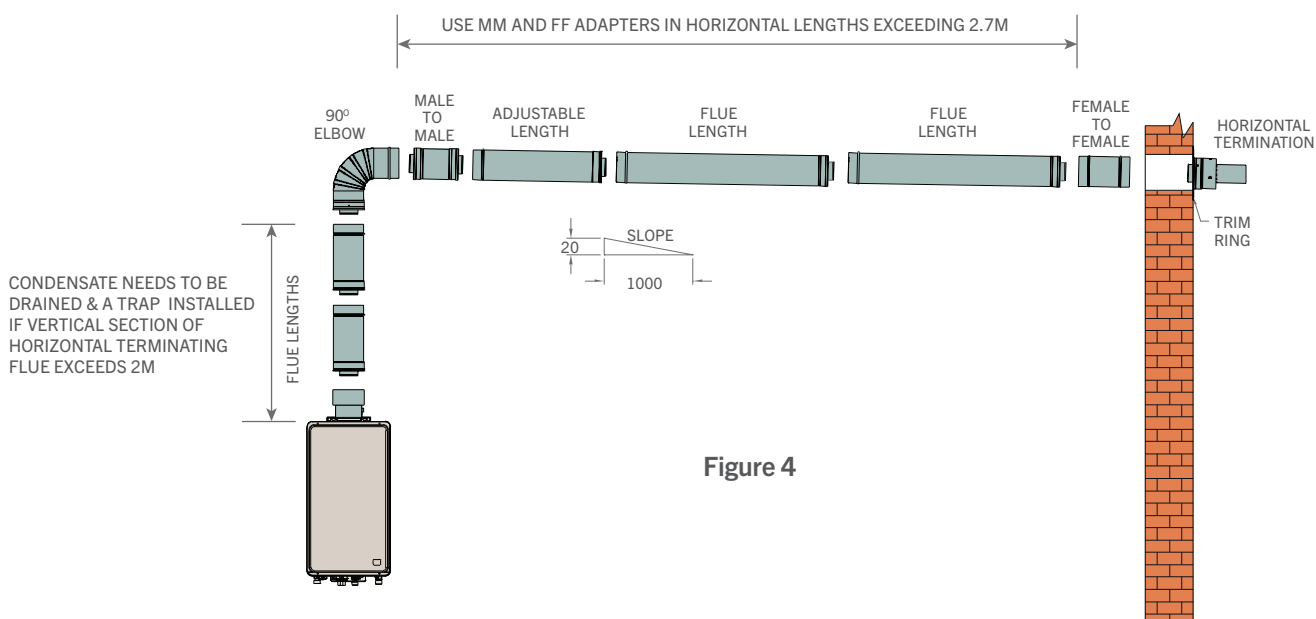

Figure 4

MALE MALE AND FEMALE FEMALE ADAPTERS

Horizontal flue sections in through the wall flue systems are to be oriented with a slope towards the terminal to drain any condensate which may form in the flue way and prevent any rain from draining into the flue/building.

Where the horizontal section exceeds 2.7m (ie. more than 3 x 900mm lengths) a Male Male Adapter P/No 295151 and a Female Female Adapter P/No 295150 must be used to limit the potential for condensate to pool within the flue section.

These adapters reverse the direction of the flue insertion and allow condensate to drain to the horizontal terminal without any obstruction/pooling, see Fig 4.

HORIZONTAL SECTION BETWEEN 2 X 90° ELBOW CREATING A VERTICAL SECTION MUST SLOPE TOWARDS THE WATER HEATER. CONDENSATE NEEDS TO BE DRAINED AND A TRAP INSTALLED.

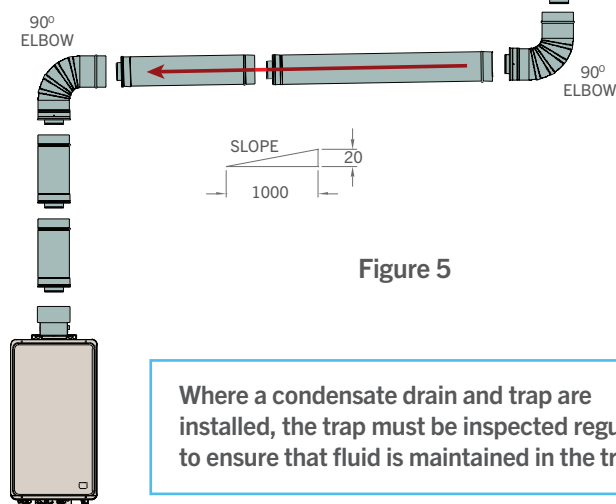

Figure 5

Where a condensate drain and trap are installed, the trap must be inspected regularly to ensure that fluid is maintained in the trap.

MULTIPLE WATER HEATER FLUE INSTALLATION

HERE'S A GUIDE TO INSTALLING MULTIPLE FLUE COMPONENTS.

- Where multiple water heaters are installed, each water heater must be individually flued to the outside. A common flue system **MUST NOT** be used
- For a multiple unit installation, the water heater is certified for installation with zero clearance between adjacent water heaters. Observe flue terminal clearances from other objects in accordance with AS/NZS 5601.1

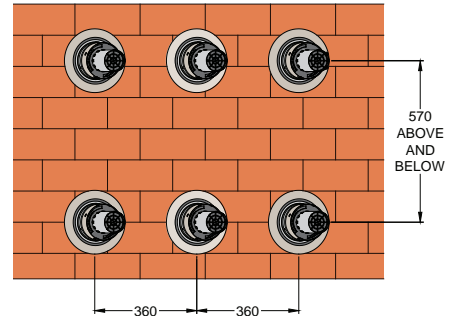
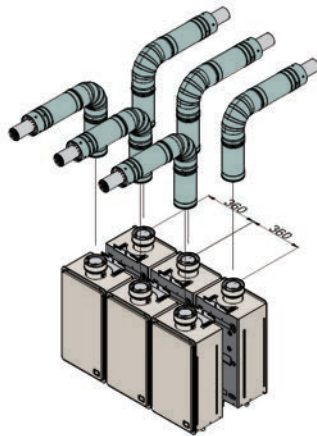

NOTE: All flues for multiple water heaters **MUST** terminate horizontally.

MAXIMUM FLUE LENGTHS

The certified flue length is 9m with a maximum of 3 x 90° elbows. The maximum flue length with no elbows can be 13.5m.

Reduce the maximum length by 1.5m for every 90° elbow and by 0.75m for every 45° elbow. The flue system is suitable for through the wall or through the roof termination when used with the horizontal terminal as shown above.

Note: It is theoretically possible to have an odd number of 45° elbows (for example a horizontal terminal installed on a wall that is 45° to the wall to which the CFWH is mounted) and in this instance the equivalent length of the 45° elbow should be added or subtracted as required.

FLUEING THROUGH THE ROOF

- The minimum side by side centre to centre distance between flue terminals is to be no less than 360mm
- Run the flueing through the roof as dictated by plant room requirements
- Each flue is to be terminated horizontally by using 90° elbows (PN 295147) and horizontal flue terminals (PN 295146)
- The flue terminals for back to back water heaters should be installed 180° opposite to each other as shown

FLUEING THROUGH THE WALL

- The minimum horizontal centre to centre distance between flue terminals is to be no less than 360mm
- The minimum vertical centre to centre distance between flue terminals is to be no less than 570mm

NO. OF 90° ELBOWS	NO. OF 45° ELBOWS	MAXIMUM FLUE LENGTH (m)
0	-	13.5
1	-	12.0
2	-	10.5
3	-	9.0
4	-	7.5
5	-	6.0
-	1	12.75
-	2	12.0
-	3	11.25
-	4	10.5
-	5	9.75
-	6	9.0
-	7	8.25
-	8	7.5
-	9	6.75
-	10	6.0

FLUE COMPONENTS

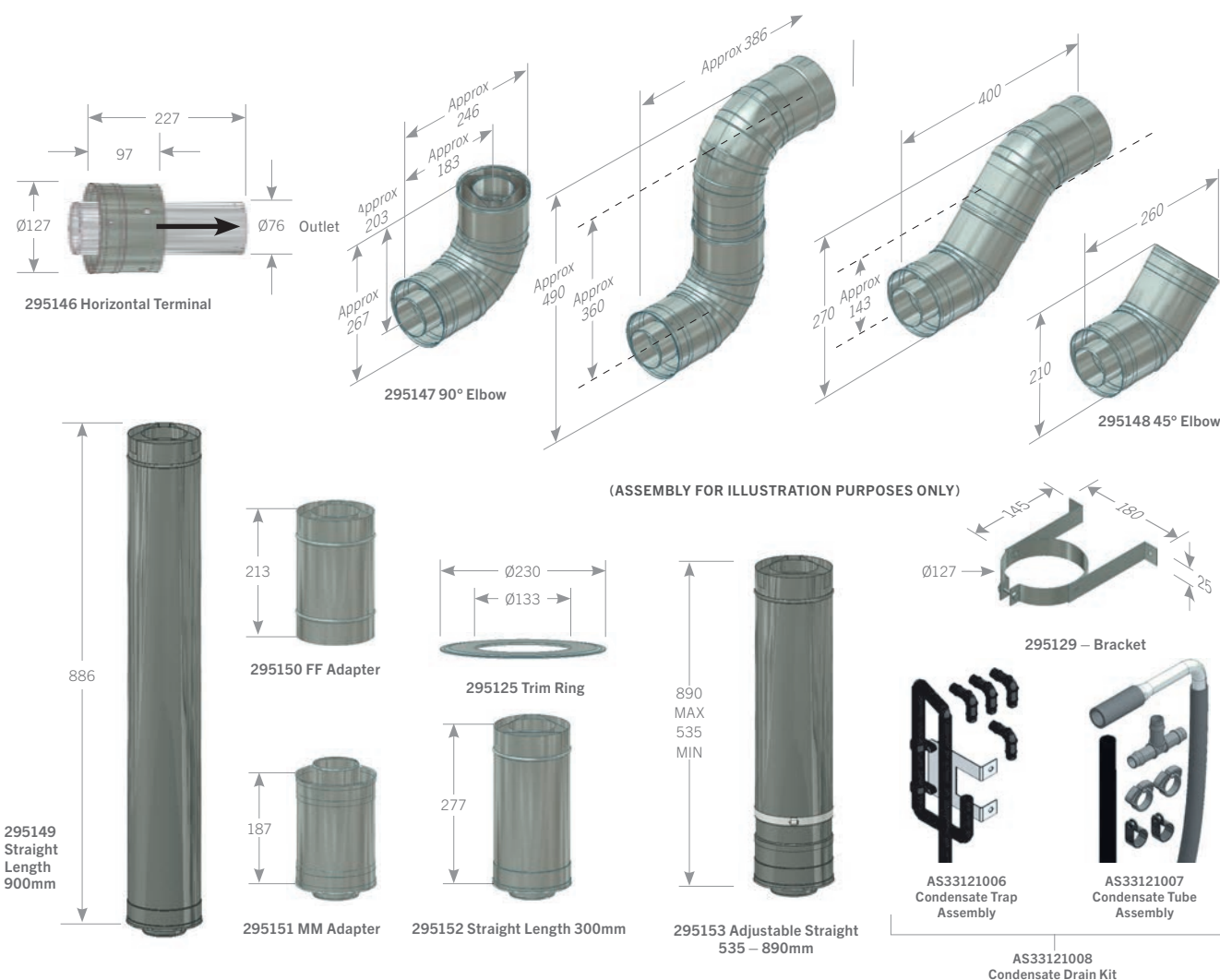

Use the following table as a guide to selecting Rheem Continuous Flow flue components:

P/N/O	DESCRIPTION	WHERE USED
295146	Horizontal Terminal	Required for all flue terminations
295147	90° Elbow	Maximum of 5 per installation
295148	45° Elbow	Maximum of 10 per installation (with no 90° elbows)
295149	Straight Length 900mm	Long straight sections
295150	Female Female Adapter	Required to reverse flue pipe direction to allow condensate to drain away correctly from water heater in long horizontal sections of horizontally terminating flues
295151	Male Male Adapter	Required to reverse flue pipe direction to allow condensate to drain away correctly from water heater in long horizontal sections of horizontally terminating flues
295125	Trim Ring (optional)	Conceal internal and/or external hole in wall for horizontally terminating flues
295152	Straight Length 300mm	Short straight sections
295153	Adjustable Length 535 – 890mm	Allows to trim flue to exact length required
295129	Bracket	Support flue at intervals not exceeding 2m and after any elbow
AS33121006	Kit Condensate Trap Assembly	One per system for inline or wall mounted. Two per system for B2B
AS33121007	Kit Condensate Tube Assembly	One required per CFGWH
AS33121008	Kit Condensate Drain	One required for individual CFGWH

CO-AXIAL FLUE SPECIFICATION	MATERIAL/DIAMETER
Inner flue	316 or 444 SS / 75
Outer flue	Aluminised Steel / 125

HEAVY DUTY STORAGE GAS

The work-horse hot water system that keeps on working, in a wider range of water quality environments.



CASE STUDY

PRESTONS LODGE AGED CARE SYDNEY, NSW

Challenge

Prestons Lodge is a 132-bed aged-care facility built in 2016 by Advantaged Care. With a daily hot water load for the facility of 9175 litres, the challenge was to provide energy efficient, budget-conscious options for the hot and warm water plant requirements.

Hot Water Solution

Approached during the design stage, Rheem provided an energy efficient solar and warm water proposal that included budget estimates, STC rebates and pay back periods.

The final installed solution included 3 x Heavy Duty Gas water heaters, 38 x NPT solar collectors and 14 x storage tanks along with 1 x 240L/min Guardian warm water and 2 x 250L/min ultraviolet disinfection



HEAVY DUTY STORAGE GAS

SUITED TO ALL APPLICATIONS IN ANY POTABLE WATER



GAS



IMPERVIOUS



FAST REPLACEMENT



EASY TO MAINTAIN



HEATS WATER UP TO 82°

HIGHLY RELIABLE AND IMPERVIOUS TO A WIDER RANGE OF WATER TYPES

A staple of the market for over 25 years, the storage cylinder is made from a special grade of steel, lined with a double coat of heavy duty vitreous enamel, and incorporates multiple anodes making it impervious to the widest variety of water chemistries.

GOLD-STANDARD REDUNDANCY AND EASY TO MAINTAIN

As each unit is stand alone, the failure of a single component doesn't render the entire system off line. Plus a simple design combines the burner and the tank without the need for pumps, making it more reliable and easy to maintain.

MULTIPLE INSTALLATION OPTIONS

There are three sizes in outdoor and indoor versions and indoor models can be flued individually or joined into a common flue.

ACCURATE AND RELIABLE TEMPERATURE MANAGEMENT

Electronic thermostat provides fine temperature control with digital setting display on the 265 and 275 and Hot Surface Ignition (HSI) removes the need for a pilot light, lowers operating costs and improves reliability because of a built-in 100% flame failure control.

REDUCES ENERGY USE

The flue damper on the 624275 indoor closes off the primary flue when the burner isn't operating, reducing maintenance rates by up to 60% when compared to AGA maximum allowance.



*Images shown may differ from actual product

MORE KEY FEATURES

- Sizes include 260 (51MJ), 265 (110MJ), 275 (200MJ)
- No electrical connection required for the smallest unit (260)
- BMS capability built in for 265 and 275 models



*Conditions Apply: For full terms and conditions please contact Rheem or visit www.rheem.com.au/rheem/help/Warranties

TECHNICAL DATA

DIMENSIONS AND TECHNICAL DATA TABLE			OUTDOOR MODELS			INDOOR MODELS		
Model			630 260 ²	634 265	634 275	620 260	624 265	624 275
Storage Capacity		litres	260	265	275	260	265	275
Dimensions								
	A	mm	1640	1840	1885	1660	1805	1910
	B	mm	590	610	645	590	610	645
	C	mm	680	745	780	670	745	780
	D	mm	1320	1461	1454	1320	1461	1454
	E	mm	330	711	704	330	711	704
	F	mm	295	340	341	297	340	341
	G	mm	1520	1661	1706	1520	1661	1706
	H	degrees	27	35	33	27	35	33
	K	mm	655	654	692	655	654	692
	M	mm	–	–	–	100	125	200
	P	mm	420	383	383	–	–	–
Weight – Empty		kg	110	144	174	101	137	167
Inlet/Outlet Connections (BSPF)			RP1¼	RP1¼	RP1¼	RP1¼	RP1¼	RP1¼
Gas Connection (BSPF)			RP½	RP¾	RP¾	RP½	RP¾	RP¾
T&PR Valve Connection (BSPF)			RP¾	RP¾	RP¾	RP¾	RP¾	RP¾
T&PR Valve Setting		kPa	1000	1000	1000	1000	1000	1000
Expansion Control Valve (ECV) ¹ Setting		kPa	850	850	850	850	850	850
Max. Water Supply Pressure								
without ECV ¹ fitted		kPa	800	800	800	800	800	800
with ECV ¹ fitted		kPa	680	680	680	680	680	680
Max. Thermostat Setting		°C	65	82	82	65	82	82
Factory Thermostat Setting		°C	60	70	70	60	70	70
Min. Thermostat Setting		°C	off	60	60	off	60	60
Manifold – Min. Centre to Centre		mm	920	920	890	845	860	890
Electrical Connection			–	2m 10A Plug and Lead		–	2m 10A Plug and Lead	
Electrical Rating 240V 50Hz			–	150 Watts	250 Watts	–	150 Watts	150 Watts
				0.65 Amps	1.1 Amps		0.65 Amps	0.65 Amps
Maintenance Rate		MJ/day	30.7	42.7	50.7	33.9	53.3	26.1

¹ Expansion control valve not supplied with water heater.

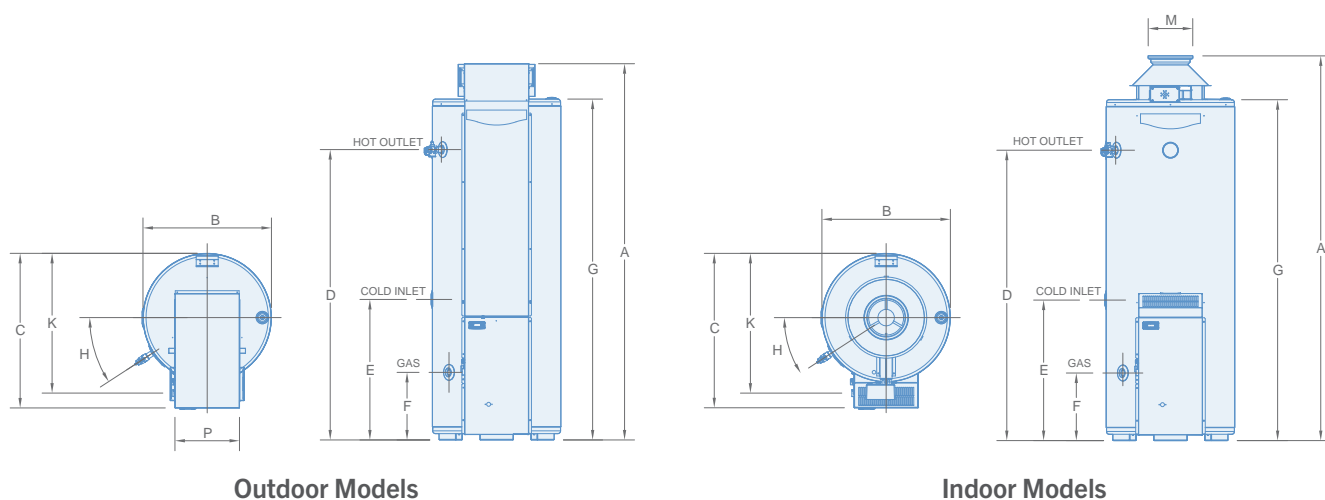

TECHNICAL DATA

PERFORMANCE DATA									
Model	No. of Units in Parallel	Initial Storage Capacity (Litres)	Thermal Input (MJ/h)	Litres hot water at 50°C rise over peak period (based on natural gas)					
				1 hour	2 hours	3 hours	4 hours	6 hours	8 hours
620 260 & 630 260 ²	1	260	51	380	570	760	950	1330	1700
	2	520	102	770	1140	1520	1900	2650	3410
	3	780	153	1150	1720	2280	2850	3980	5110
624 265 & 634 265	1	265	110	620	1030	1440	1850	2670	3490
	2	530	220	1240	2060	2880	3700	5340	6980
	3	795	330	1870	3100	4330	5560	8010	10470
624 275 & 634 275	1	275	200	970	1710	2460	3200	4690	6180
	2	550	400	1930	3420	4910	6400	9380	12370
	3	825	600	2900	5130	7370	9600	14080	18550
	4	1100	800	3860	6840	9820	12810	18770	24730
	5	1375	1000	4830	8550	12280	16010	23460	30910
	6	1650	1200	5790	10260	14740	19210	28150	37100

Model	No. of Units in Parallel	Initial Storage Capacity (Litres)	Thermal Input (MJ/h)	Litres hot water at 65°C rise over peak period (based on natural gas)					
				1 hour	2 hours	3 hours	4 hours	6 hours	8 hours
624 265 & 634 265	1	265	110	530	840	1160	1470	2100	2730
	2	530	220	1050	1690	2320	2950	4210	5470
	3	795	330	1580	2530	3470	4420	6310	8200
624 275 & 634 275	1	275	200	790	1370	1940	2510	3660	4810
	2	550	400	1590	2730	3880	5030	7320	9610
	3	825	600	2380	4100	5820	7540	10980	14420
	4	1100	800	3170	5470	7760	10050	14640	19230
	5	1375	1000	3970	6830	9700	12570	18300	24030
	6	1650	1200	4760	8200	11640	15080	21960	28840

Note: Hot water figures rounded to the nearest 10 litres.

OPERATIONS AT TEMPERATURE ABOVE 80°C

Rheem Commercial gas models 624 265, 634 265, 624 275, 634 275 are designed to operate at temperatures up to 82°C for sanitising and other applications.

Where the water supplied by the water heater is required consistently

at any temperature above 80°C, we strongly recommend you use a pumped recirculation system. (Please refer to the Equa-Flow® section.)

GAS PIPE SUPPLY

The gas supply piping should be sized in accordance with AS/NZS 5601.1. The gas supply pipe must be sized

so that the minimum gas pressure is available at the inlet to each water heater when all appliances are operating at maximum gas consumption.

The minimum gas pressures are 1.13 kPa for natural and SNG, 2.75 kPa for propane and butane and 0.75 kPa for town gas and TLP.

TECHNICAL GAS PERFORMANCE DETAILS									
Model		620 260 & 630 260 ²		624 265 & 634 265			624 275 & 634 275		
		Nat/SNG	Propane	Nat/SNG	Propane	Butane/NZLPG	Nat/SNG	Propane	Butane/NZLPG
Gas Type									
Thermal Input	MJ/h	51	51	110	100	95	200	190	160
Output	kW	11.0	11.0	23.8	21.7	20.6	43.3	41.2	34.7
Min. Gas Supply Pressure	kPa	1.13	2.75	1.13	2.75	2.75	1.13	2.75	2.75
Test Point Pressure	kPa	1.00	2.70	0.90	2.50	2.50	0.90	2.65	2.65
Max. Gas Supply Pressure	kPa	3.5	3.5	3.5	3.5	3.5	3.5	3.5	3.5
Litres Recovery per hour at rise of	20°C	480	480	1030	940	890	1870	1780	1500
	30°C	320	320	690	630	600	1250	1190	1000
	40°C	240	240	520	470	450	940	890	750
	50°C	190	190	410	380	360	750	710	600
	60°C	160	160	350	320	300	630	600	500
	65°C	150	150	320	290	280	580	550	460
	70°C	140	140	300	270	260	540	510	430
75°C	130	130	280	250	240	500	480	400	

² 620260 and 630260 not available in Butane/NZLPG.



TECHNICAL HEAVY DUTY GAS BUILT-IN BMS DATA

The Rheem Heavy Duty Gas built-in BMS contacts (Voltage Free) is designed to interface between individual gas water heaters and the building management system to remotely provide facility managers with real time water heater status for 265 and 275 models. The connection point is located on the left hand side of the front cover, above the gas inlet.

FEATURES

- Provides a Run / Fail signal via voltage free N/O, N/C and Common contacts
- Has a contact rating of 10A @ 240V
- Requires field connection of the N/O, N/C and Common contacts
- Each water heater in a bank must be individually connected to the BMS system

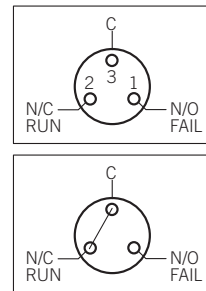

Voltage Free Contact Rating:
Max 10A, 240V

VENTILATION AND FLUEING

VENTILATION FOR INDOOR GAS WATER HEATERS

In Australia and New Zealand, gas water heaters installed indoors (non room sealed) require to be ventilated in accordance with AS5601 or AS/NZS 5601.1 depending on the local regulations.

AS/NZS 5601.1 also has further requirements regarding compliance of mechanical ventilation.

Please consult the appropriate standard when designing plant room ventilation requirements.

NOTES

In plant rooms, wherever possible more than one wall should be used to provide ventilation. This allows a flow of air across the room and helps prevent excessive temperatures in the room.

POWER FLUEING / MECHANICAL VENTILATION

You can either install an individual Rheem gas model or a bank of multiple 624 265, 624 275 models with a power flue or mechanical air supply.

It's essential to prove the flue system operates correctly before the main burner is allowed to operate.

How is this achieved? A self proving relay interlocked with either a vane switch or pressure differential switch will prove both air flow and functionality of the control circuit before ignition of the main burner.

Please refer to AS/NZS 5601.1 for full details of what's required.

For multiple installations, the operating principle is the same as for a single water heater.

Any water heater can switch on the fan, and the burners can only come on when the sail switch is closed.

POWER FLUE EXTERNAL CONTROLS – INTERMITTENT OPERATION

For a single water heater installation, connect ① and ② directly to the water heater

DETAIL 1

INTERMITTENT FAN OPERATION FAN LOAD EXCEEDING 5 AMPS

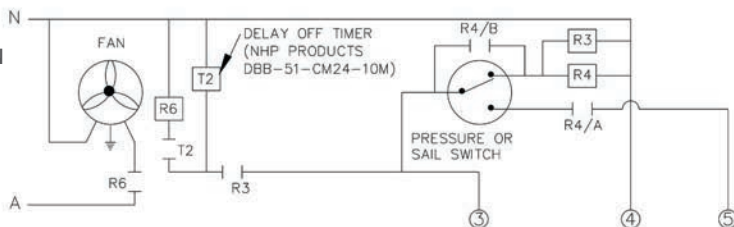

DETAIL 2

INTERMITTENT FAN OPERATION FAN LOAD NOT EXCEEDING 5 AMPS

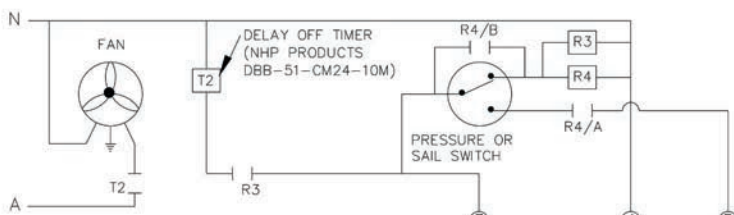

NOTES

1. Power source for the water heater, fan and control circuit must be from the same circuit.
2. R1 monitors return signal.
3. R2 monitors alarm signal.
4. T1 to be set for 20-30 seconds.
5. Meets requirements of Clause H2.2.5 of AS/NZS 5601.1 providing lockout in the event of flue product flow failure.
6. Where intermittent fan operation is utilised, it is necessary to run the fan for some time after combustion ceases to prevent flue spillage of combustion products. T2 to be set for 5 minutes.

For multiple water heater installation, connect ① and ② to the water heater via a relay box as shown in Detail 3

DETAIL 3
RELAY BOX

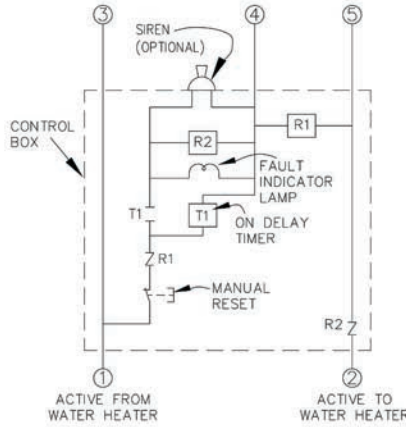
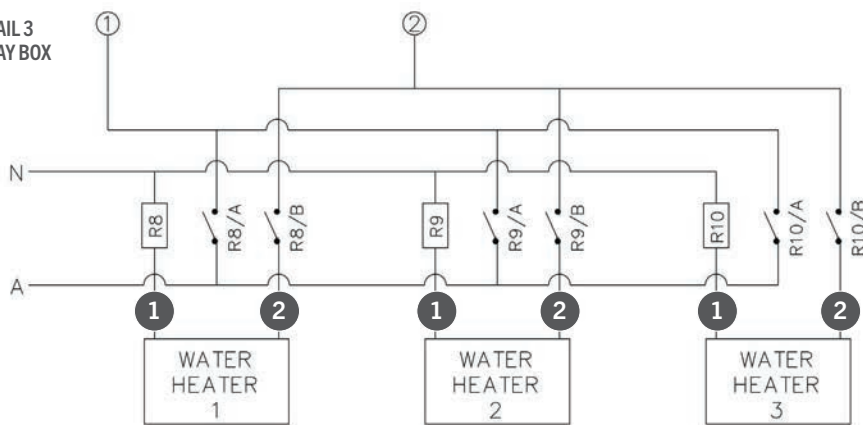

DETAIL 4
POWER FLUE INTERLOCK TERMINALS LOCATED WITHIN THE 265, 275 FRONT COVER

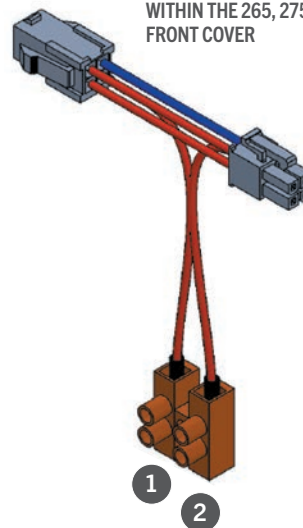

Intermittent Power Flue Fan Control – Multiple Water Heater Rheem 624 Series.

TECHNICAL DATA

POWER FLUE AND REMOTE CONTROL

Rheem commercial models 624 265, 634 265, 624 275, 634 275 may be controlled by a remote device such as a time clock, BMS remote isolating switch, pressure switch or sail switch. Additionally, Rheem can assist with Power Flue design solutions for Rheem and Raypak® commercial gas water heaters. For further details please contact your local Rheem technical advisory service.

FLUEING: MINIMUM DISTANCES FOR OUTDOOR GAS WATER HEATERS

Rheem outdoor gas water heaters have a balanced flue and do not require the addition of secondary flueing. Minimum clearance requirements, as stated in

AS/NZS 5601.1, apply to the location of outdoor balanced flue, room sealed or power flue terminals.

The Standard also states that where a balanced flue or room sealed terminal is installed under a covered area, then the covered area is to be open on at least two sides and the terminal is to be located to ensure a free flow of air across the terminal.

FLUEING: INDOOR GAS WATER HEATERS

Manifolded water heaters can either be flued individually or connected to a common flue. The design of the flue must comply with Appendix H of the Standard.

AS/NZS 5601.1 states the vertical rise directly out of the water heater must be the maximum possible height before any change in direction.

Also, the total length of the lateral (horizontal) section must be as short as possible, not exceeding 50% of the total flue height of the system.

The table and diagram below are extracted from the Flue Tables in AS/NZS 5601.1 and are meant as a quick guide only. Any variations should be referenced from AS/NZS 5601.1.



Appropriate authorities should be consulted before any work is commenced on flues other than single appliance flues.



Additionally Rheem requires the water heater be installed with the back of the unit against a wall or alternatively against a solid fireproof screen extending at least 500mm above, below and either side of the flue terminal.



Rheem indoor gas water heaters are designed for connection to a flue system in accordance with the requirements of AS/NZS 5601.1.

TECHNICAL DATA

Multiple Manifold Flue System

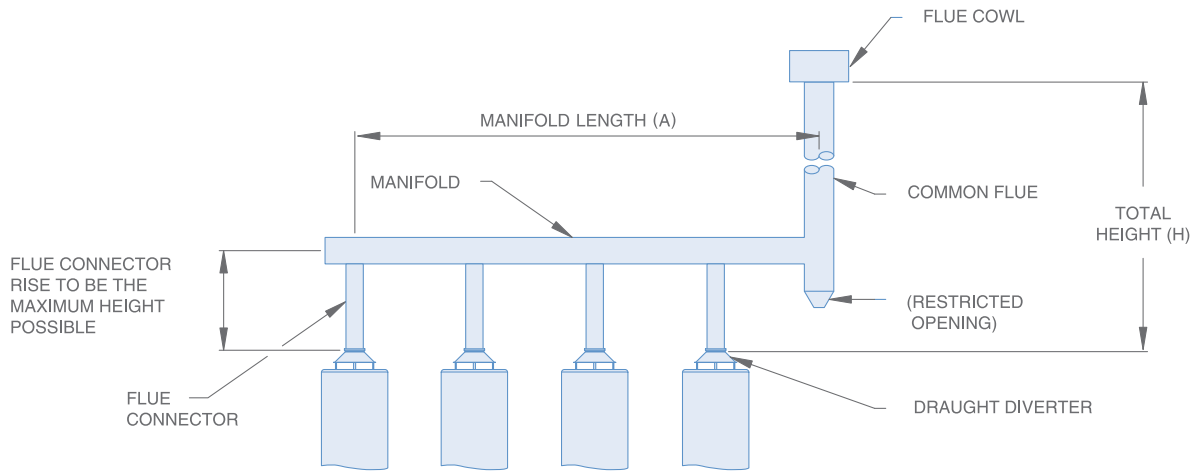

NOTES: The length of manifold "A" should not exceed 50% of total flue height "H".

FLUE SIZING FOR GAS WATER HEATERS											
Model	Total Flue Height (H) (m)	1		2		4		6		8	
		Max. Lateral (m)	Flue Dia (mm)	Max. Manifold Length (A) (m)	Flue Dia (mm)	Max. Manifold Length (A) (m)	Flue Dia (mm)	Max. Manifold Length (A) (m)	Flue Dia (mm)	Max. Manifold Length (A) (m)	Flue Dia (mm)
620 260 51 MJ/h	2	1.0	100	1.0	150	-	-	-	-	-	-
	3	1.5	100	1.5	125	-	-	-	-	-	-
	6	3.0	100	3.0	125	3.0	175	-	-	-	-
	12	6.0	100	6.0	100	6.0	150	6.0	175	-	-
624 265 110 MJ/h	24	7.6	150	12.0	150	12.0	150	12.0	175	12.0	200
	2	1.0	150	1.0	200	-	-	-	-	-	-
	3	1.5	125	1.5	200	-	-	-	-	-	-
	6	3.0	125	3.0	175	3.0	250	-	-	-	-
624 275 200 MJ/h	12	6.0	125	6.0	150	6.0	200	6.0	250	-	-
	24	7.6	150	12.0	150	12.0	200	12.0	250	12.0	300
	2	1.0	175	1.0	300	-	-	-	-	-	-
	3	1.5	175	1.5	250	-	-	-	-	-	-
	6	3.0	150	3.0	250	3.0	300	-	-	-	-
	12	6.0	150	6.0	200	6.0	300	6.0	350	-	-
	24	7.6	150	12.0	200	12.0	250	12.0	300	12.0	350

NOTES: The table is based on a natural draft system with an insulated type flue or a flue installed indoors
The table is extracted from the Flue Tables in AS/NZS 5601.1 and is meant as a quick guide only. Any variations should be referenced from AS/NZS 5601.1

RAYPAK[®] MVB[®]

A vertically fired, modulating gas water heater for both hydronic and domestic hot water heating.



CASE STUDY

FOOTBALL SA GEPPTS CROSS, SA

Challenge

Gepps Cross Sports Park is the new world-class State Centre for Football SA, including a show pitch with 5,000 spectator capacity, a multipurpose centre, training pitches and gymnasium.

Secon Consulting designed the indoor centralized hot water system servicing the administration and function centre, change rooms, general amenities and commercial kitchen, kiosk, and bar facilities.

Hot water solution

Stacked horizontal discharge Heat Pumps were installed as the primary heat source with large capacity storage. A Raypak MVB was chosen as a hybrid booster for its flexible flueing options, high efficiency, high output and its small footprint. PA Plumbers installed the System:

- 2 x Rheem 16kW Air to Water (A2W) Commercial Heat Pumps
- 2 x Rheem 1000L RT-Series Storage Tanks
- 1 x Raypak 1000MJ MVB
- 1 x Rediset Deluxe building recirculation system



RAYPAK® MVB®

FOR SUPERIOR EFFICIENCY
IN SMALL SPACES



GAS



COMPACT



THERMAL
EFFICIENCY



FLEXIBLE
FLUEING



TOUCHSCREEN
WITH BMS

Raypak MVB – Modulating Vertical Burner – is a vertically fired, full modulation capable gas water heater designed for both hydronic heating and domestic hot water applications, and can even do both simultaneously.

EFFICIENCY

Up to 88.4%¹ thermal efficiency in a non-condensing platform provides good practical efficiency in high temperature circuits. Incorporates unique integral evaporator system which collects and re-evaporates condensate which may form under certain conditions, eliminating the need for a boiler condensate drain. Can operate as low as 49°C without additional bypasses.

SMALL FOOTPRINT

With less than 2.4m² of installed space per heater fitting into tight spaces is a breeze. Fits through a standard 800mm doorway for replacement ease.

FLEXIBLE FLUEING

A variety of small diameter flueing options including traditional vertical flueing, horizontal, room sealed and outdoor with exceptional flue run lengths provide installation flexibility. Flue versatility is further enhanced by the self-tuning combustion system which compensates for unusual flue configurations.

¹ Part load. 86.2% full load.

CONTROL INTERFACE WITH BMS

7" colour touchscreen user interface provides instant visual information. The modulating VERSA IC Controller merges safety, ignition and temperature control, outdoor reset and freeze protection, plus system monitoring, alarm and diagnostics with VFC remote alarm, and BMS transmission all in one Integrated Control Platform.

The MVB is factory configured for Modbus RTU BMS communication (with extension capability). Supplied BMS gateways include:

- Modbus communication port - Standard
- BACnet MS/TP, BACnet IP, N2 Metasys or Modbus TCP, LONWorks - Optional



*Conditions Apply: For full terms and conditions please contact Rheem or visit www.rheem.com.au/rheem/help/Warranties

ADDITIONAL FEATURES AND BENEFITS



MASTER

FOLLOWERS

CONTROL

- Air: Gas ratio burner control can provide up to 7:1 turndown on each heater (14% minimum fire rate) and up to 4 heaters can be internally cascade connected, with equal runtime auto rotation, to provide up to 28:1 system turndown (3.5% minimum fire rate) for optimum temperature control in hydronic circuits

- MVB automatically self-tunes to accommodate the widest range of gas supply pressures. The high quality integrated blower-gas valve is self-correcting and allows smooth operation with fluctuating gas supply pressures
- Can operate up to 3,000m altitude (De-rate after 1,500m)

- 0-10V DC BMS Interface (control setpoint or direct drive unit on/off)
- Built-in outdoor reset functionality for hydronic heating
- Can simultaneously operate building pump (hydronic circuits), water heater primary pump and DHW pump in hybrid Heating/DHW circuits

COMMERCIAL TO THE CORE

- Quality components including Ebm and Amatek fan, Dungs gas valve, bronze headers and copper finned tube, structural steel base, stainless steel combustion chamber, heavy gauge galvanized steel cabinet with UV-resistant Polytuf powder coat finish passes >1000 hour salt spray test
- 7 models in the range from 527MJ/h to 1990MJ/h (126kW to 476kW)

CASE STUDIES



DEL SOL MEDICAL CENTRE

EL PASO, TEXAS, USA

Del Sol Medical Center, El Paso Texas, installed 12 x MVB H7-2003 (912000NH) water heaters indoor in December of 2011 to provide central heating.



DISTRICT HEATING CHINA

6 x MVB H7-4003 (4000MJ/hr) water heaters each (12 total) are being used to provide district heating to two separate districts in China.



NEKTAR BUILDING OAKLAND, CALIFORNIA, USA

The Nektar Building in Oakland, California installed 2 x MVB H7-4003 (4000MJ/hr) water heaters as an efficiency upgrade and to meet the new emissions requirements in the bay area in 2013 to provide central heating.

APPLICATIONS

HYDRONIC HEATING APPLICATION

MVB ('H' models) are ideal for hydronic heating due to the air:gas ratio control and up to 28:1 turndown (in cascade).

- Primary circuit and, optionally, building pump can be controlled
- Outdoor reset for optional temperature control is available
- Cascade up to 4 units for better control and improved lifetime

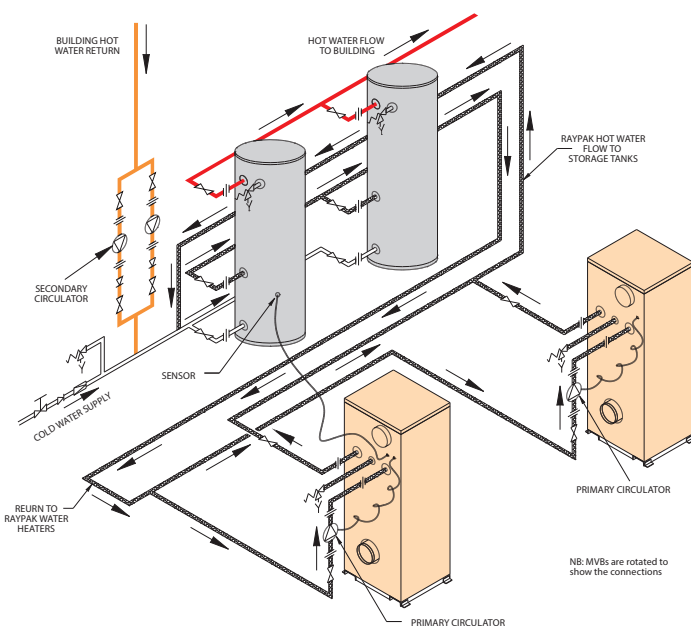
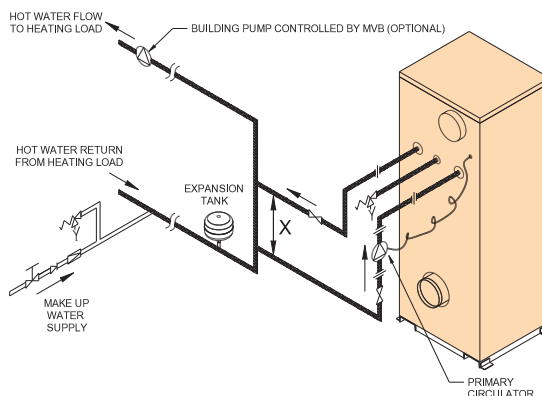

DOMESTIC HOT WATER APPLICATION

MVB is WaterMark certified for use in DHW applications.



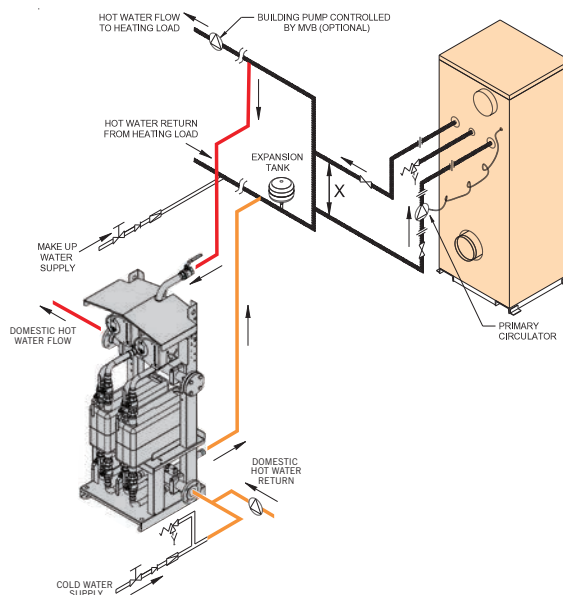







- 'W' models suitable for up to 71°C
- 'H' models suitable for higher temperatures
- Cascading and rotating options for improved lifetime



HYDRONIC HEATING AND DOMESTIC HOT WATER APPLICATION

Building heating and potable domestic hot water can be achieved as a combined system by using the MVB with Crossflow or a hot water calorifier.

- Connect Crossflow primary flow and return to the building flow and return
- Storage may or may not be required depending on the amount of available energy

LEGEND	
	STOP VALVE
	NON RETURN VALVE
	PRESSURE LIMITING VALVE
	EXPANSION CONTROL VALVE
	GATE OR BALL VALVE
	CIRCULATOR
	UNION
	TUNDISH
	DIRECTION OF FLOW
	MAXIMUM DISTANCE NOT TO EXCEED 4X PIPE DIAMETER OR 300mm, WHICHEVER IS LESS

TECHNICAL DATA

MODELS			910500	910750	911000	911250	911500	911750	912000
Natural Gas	Input	MJ/h	527	791	1054	1319	1582	1846	1990
	Output	kW	126	189	252	316	379	442	476
Dimensions									
B		mm	1092	1245	1397	1549	1702	1905	2057
D		mm	813	965	1118	1270	1422	1575	1727
E		mm	889	1041	1194	1346	1499	1651	1803
F		mm	603	756	908	1060	1213	1365	1518
G ¹			R1	R1	R1¼	R1¼	R1¼	R2	R2
H ¹			R2	R2	R2½	R2½	R2½	R2½	R2½
K		mm		150				200	
L		mm		924				954	
M		mm		368				451	
N		mm		150				200	
P		mm	889	1041	1232	1346	1499	1727	1880
R		mm	152	152	152	152	152	229	229
V		mm	51	51	51	51	51	127	127
Weight		kg	272	299	326	354	381	426	454
Relief Valve Connection			RC¾	RC¾	RC¾	RC¾	RC¾	RC¾	RC¾
Indoor Sound Pressure at 3m		dBA	63	63	63	63	63	69	69
Outdoor Sound Pressure at 3m		dBA	55	55	55	55	55	62	62
Electrical Rating 240V 50Hz		Amps ²	6.25	6.25	6.25	6.25	6.25	8.5	8.5
Min Buffer Tank Capacity		L	217	326	434	544	653	761	820
Max Storage Tank Capacity		L	6511	9767	13022	16329	19585	22840	24597
Litres Recovery Per Hour @ (Natural Gas)	30	°C rise	3617	5426	7234	9072	10880	12689	13665
	40	°C rise	2713	4069	5426	6804	8160	9517	10249
	50	°C rise	2170	3256	4341	5443	6528	7613	8199
	60	°C rise	1809	2713	3617	4536	5440	6344	6833
	65	°C rise	1669	2504	3339	4187	5022	5856	6307
	70	°C rise	1550	2325	3100	3888	4663	5438	5856
	75	°C rise	1447	2170	2894	3629	4352	5076	5466
80	°C rise	1356	2035	2713	3402	4080	4758	5124	
85	°C rise	1277	1915	2553	3202	3840	4478	4823	
Flow Rate and Pressure Drop									
Temperature Rise (°C)	10	L/s	3.13	4.62	6.18	7.23	-	-	-
		dP (kPa)	11.05	25.15	44	56.7	-	-	-
	15	L/s	2	3	4	5	6	7	-
		dP (kPa)	5	10.8	21.1	35.6	56.3	82.9	-
20	L/s	-	2.26	3	3.77	4.5	5.28	5.7	
	dP (kPa)	-	7.1	12.7	25.8	33.8	44.7	60.4	
Min Flow	L/s	1.6	2.11	2.88	3.58	4.29	4.99	5.7	
	dP (kPa)	3.35	5.79	11.58	19.81	30.48	42.67	60.35	
	dT Deg C	19.4	21.7	21.7	21.7	21.7	21.7	21.7	
Max Flow	L/s	6.4	6.4	7.23	7.23	7.23	7.23	7.42	
	dP (kPa)	34.44	42.06	56.69	67.67	77.72	82.91	97.54	
	dT Deg C	5	7.2	8.3	10.6	12.8	15	16.7	

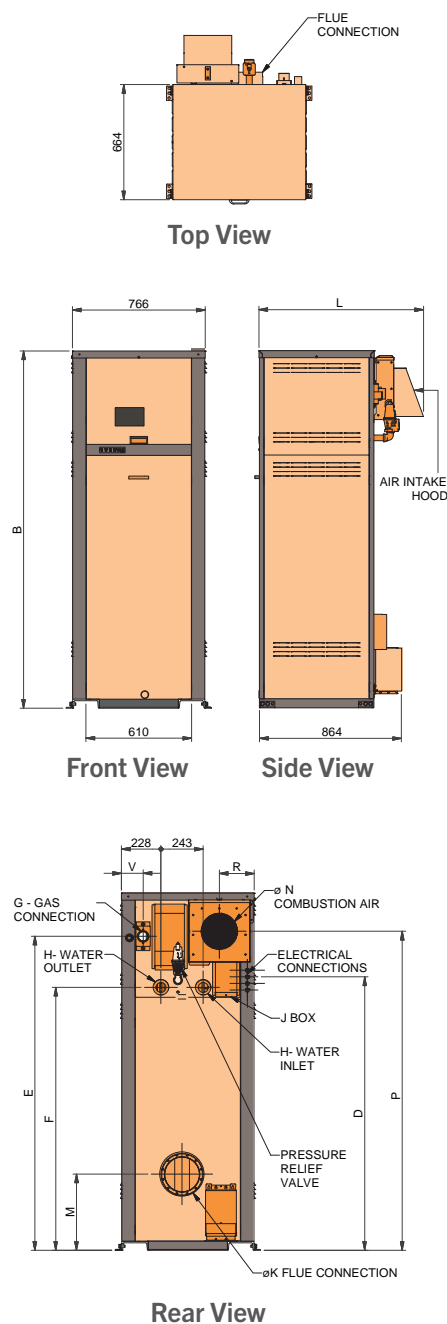

¹ Water and gas connections on the MVB are NPT threaded and will not seal against ISO 7 (BSP) threads. The NPT/BSP adaptors supplied must be fitted in order to make further connections to the system.

² Excluding pumps.

MVB MODEL NUMBERS					
91	0500	B	N/P	W/H	K
Commercial MVB	Approx. Thermal input (MJ/h)	Header Material B = Bronze	Gas Type N = Nat gas	Heater Configuration H = Hydronic W = Domestic Hot Water	K = Installation Kit
GAS SUPPLY PRESSURE			THERMOSTAT SETTINGS		
Gas Type	Natural			W Model	H Model
Minimum at Full Load (kPa)	1.13		Max	71°C	82°C
Maximum (kPa)	2.6		Factory Set	51.5°C	Mode setting dependant
			Min	10°C	10°C

CLEARANCES		
Heater Side	Minimum From Combustible Surfaces (mm)	Minimum Service Clearance (mm)
Floor ³	0	0
Rear	300	600
Right Side	25	500
Left Side	25	500
Top	0	350
Front	Open	900

³ Do not install on carpeting. NOTE: Local codes may require increased clearances.

VERSATILE APPLICATIONS FOR FLUEING

FLUEING

The MVB is a high efficiency, fan forced water heater. The flue must be of minimum 316 grade stainless steel sealed against positive flue pressure. The Rheem supplied flue components meet this requirement and are easily fitted together with gaskets and over-centre clamp rings.

The flue must be installed with fall toward the heater where condensate can be collected. The condensate drain section must be connected and drained

to the sewer waste or outside. A condensate trap must be installed and filled with water to prevent spillage of products of combustion.

HOW TO SIZE

The overall dimension of each flue piece is shown in the drawings. Allow approximately 35mm for insertion of each flue piece.

Determine the lineal distance and number of 45° and/or 90° elbow between the MVB outlet and flue

terminal in accordance with the table. Note, the bottom edge of a vertical flue terminal must be 500mm away from the nearest structure in accordance with AS/NZS 5601.1.

Flashing is required to be installed where a vertical flue section penetrates the roof line (not supplied).

Flue penetrations through walls and ceilings must be sealed in accordance with local fire regulations.

MVB Model	Flue Material	Flue Size (mm)	Max Flue Length ⁴ (m)	Combustion Air Intake Pipe Material	Max Air Inlet Length ⁴ (m)		
					Ø 150mm	Ø 200mm	Ø 250mm
910500	316L Stainless Steel minimum	150	23	Stainless Steel, Galvanized Steel, PVC, ABS, CPVC	14	30	N/A
910750							
911000							
911250	316L Stainless Steel minimum	200	23	Stainless Steel, Galvanized Steel, PVC, ABS, CPVC	N/A	14	26
911500							
911750							
912000							

⁴ Subtract 3m for every elbow. Max 4 x elbows. Flue terminal not considered as part of the overall length of the flue system.

Room Sealed Vertical Flueing

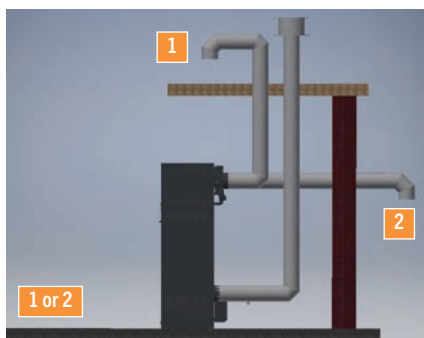

Room Sourced Vertical Flueing



Outdoor Flueing

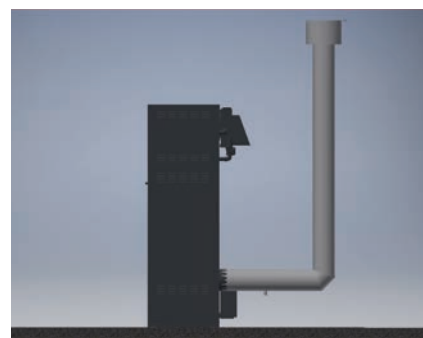

Room Sealed Horizontal Through-the-Wall Flueing

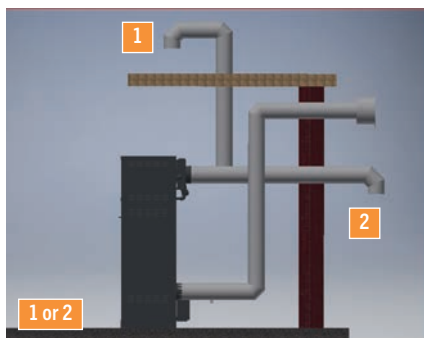

Room Sourced Horizontal Through-the-Wall Flueing

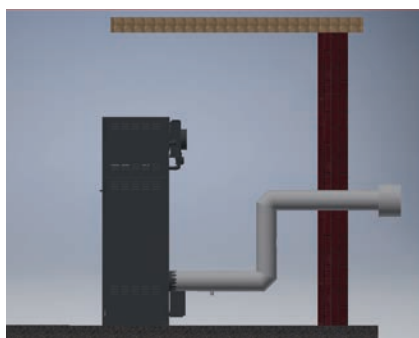

Alternative Outdoor Through-the-Wall Flueing

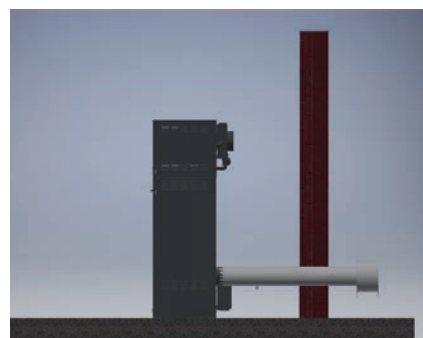

FLUEING AND ACCESSORIES

The MVB is supported by a range of stainless steel flue components suitable for positive pressure condensing operation. Ø150mm suits 910500, 910750 and 911000. Ø200mm suits 911250, 911500, 911750 and 912000.

The following parts are available:

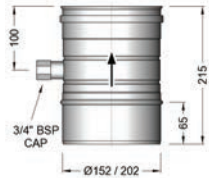

Flue Adaptor with Drain
 Ø150mm - AQ94200106
 Ø200mm - AQ94200127

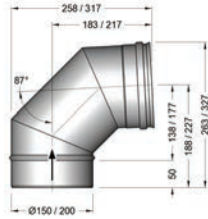

87° Elbow
 Ø150mm - AQ94200108
 Ø200mm - AQ94200129

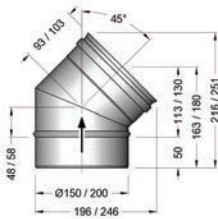

45° Elbow
 Ø150mm - AQ94200109
 Ø200mm - AQ94200130

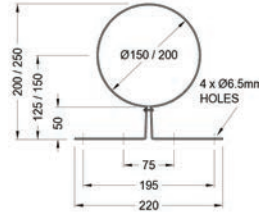

Mounting Band (1 per 1.5m of run)
 Ø150mm - AQ94200116
 Ø200mm - AQ94200137

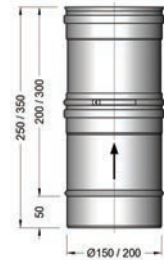

Adjustable Straight
 Ø150mm - AQ94200113
 Ø200mm - AQ94200134

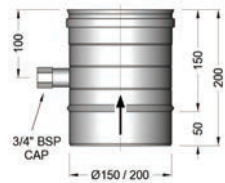

Flue Drain (project specific)
 Ø150mm - AQ94200107
 Ø200mm - AQ94200128



Top Stub (vertical discharge)
 Ø150mm - AQ94200120
 Ø200mm - AQ94200143

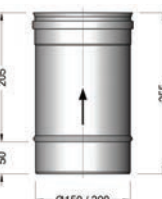

250mm Straight
 Ø150mm - AQ94200112
 Ø200mm - AQ94200133

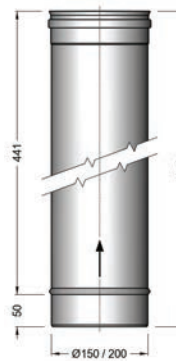

500mm Straight
 Ø150mm - AQ94200111
 Ø200mm - AQ94200132

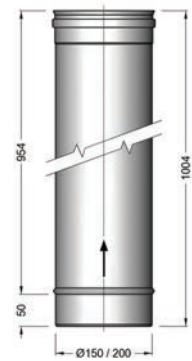

1000mm Straight
 Ø150mm - AQ94200110
 Ø200mm - AQ94200131

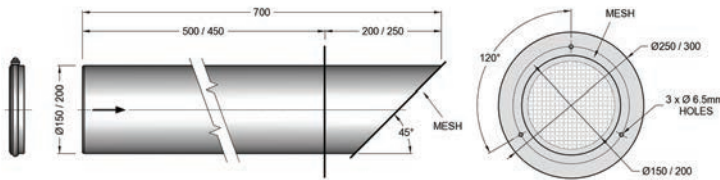

Horizontal Terminal[®] (can be cut to length)
 Ø150mm - AQ94200121 Ø200mm - AQ94200144



Lock Band with Clamp (1 per flue piece)
 Ø150mm - AQ94200114
 Ø200mm - AQ94200135

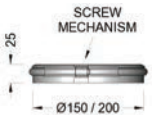

Lock Band with Screw
 Ø150mm - AQ94200115
 Ø200mm - AQ94200136

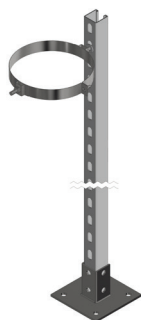

Outdoor Flue Stand Collar
 Ø150mm - AQ94200223
 Ø200mm - AQ94200224
 Base and Stand not included.



Lubricating Grease 250g (approx. 1 required per 15 sections of flue)
 AQ0080503

ACCESSORIES

Part Number	Description
AQ2415001	Kit Fitting Adapter 500 – 750 (supplied with MVB)
AQ2415002	Kit Fitting Adapter 1000 – 1500 (supplied with MVB)
AQ2415003	Kit Fitting Adapter 1750 – 2000 (supplied with MVB)
AQ0200125	Interface Module Gateway BACnet/Metasys
AQ0200126	Interface Module Gateway Lonworks
0107867	Outdoor Air Sensor ('H' Models)
AQ0200127	Temperature Controller – Pump-C ('H' models used for DHW >71°C)
AQ94200225	Pump Cover Magna 1
56860243-1	PUMP GRUNDFOS UPS32-80N
AQ0202044	PUMP GRUNDFOS MAGNA 1 40-120
AQ0202045	PUMP GRUNDFOS MAGNA 1 65-150
AQ2415025	Sensor Kit NTC J Curve (supplied with MVB. An additional sensor kit may be required, application dependent.)

PIPE SIZE AND PUMP SELECTION

MVB PIPE SIZE AND PUMP SELECTION CHART FOR DOMESTIC HOT WATER AND HYDRONIC APPLICATIONS UP TO 65°C (20 DEGREE RISE)

MVB Model	Pump Model	Branch Size (mm)	Minimum Manifold Header Size (mm) / Pump Speed Setting							
			1 Unit		2 Units		3 Units		4 Units	
			Pipe Dia. (mm)	Speed	Pipe Dia. (mm)	Speed	Pipe Dia. (mm)	Speed	Pipe Dia. (mm)	Speed
910500	UPS32-80N	50	50	3	65	3	80	3	100	3
910750	UPS32-80N	65	65	3	80	3	100	3	100	3
911000	Magna 1 40-120	65	65	PP1	100	PP1	100	CP1	125	PP1
911250	Magna 1 40-120	80	80	CC2	100	CC2	125	CC2	125	CC3
911500	Magna 1 40-120	80	80	CC3	100	CC3	125	CC3	150	CC3
911750	Magna 1 65-150	100	100	CC2	125	CC2	150	CC2	200	CC2
912000	Magna 1 65-150	100	100	PP2	125	PP2	150	PP2	200	PP2

NOTE: Manifold header sizes are minimum requirements for water heater performance. Header sizing is based on a total length of 20m of primary flow and return piping and 20 bends, excluding equa-flow manifolds on storage tanks and MVBs, at 1.2m/sec velocity in copper pipe.

MVB PIPE SIZE AND PUMP SELECTION CHART FOR DOMESTIC HOT WATER AND HYDRONIC APPLICATIONS BETWEEN 65°C AND 82°C (15 DEGREE RISE)

MVB Model	Pump Model	Branch Size (mm)	Minimum Manifold Header Size (mm) / Pump Speed Setting							
			1 Unit		2 Units		3 Units		4 Units	
			Pipe Dia. (mm)	Speed	Pipe Dia. (mm)	Speed	Pipe Dia. (mm)	Speed	Pipe Dia. (mm)	Speed
910500	UPS32-80N	50	50	3	80	3	100	3	100	3
910750	Magna 1 40-120	65	65	PP1	100	PP1	100	PP1	125	PP1
911000	Magna 1 40-120	80	80	PP1	100	CC2	125	PP1	150	PP1
911250	Magna 1 40-120	80	80	CC3	125	CC3	125	CC3	150	CC3
911500	Magna 1 65-150	100	100	CC2	125	PP2	150	PP2	200	CC2
911750	Magna 1 65-150	100	100	CC3	125	CC3	150	CC3	200	CP3
912000	Magna 1 65-150	100	100	CC3	125	CC3	150	CC3	200	CC3

NOTE: Manifold header sizes are minimum requirements for water heater performance. Header sizing is based on a total length of 20m of primary flow and return piping and 20 bends, excluding equa-flow manifolds on storage tanks and MVBs, at 1.2m/sec velocity in copper pipe.

Water Supply and Relief Valve Settings

OPERATION TYPE	W Models (DHW)	H Models ⁷ (HHW)
Relief Valve Setting (kPa)	1000 (850) ⁵	415
Expansion Control Valve (ECV) ⁶ Setting (kPa)	850 (700) ⁵	N/A
Minimum Water Supply Pressure		
System water temperatures up to 65°C (kPa)	70 (7m)	70 (7m)
System water temperatures above 65°C (kPa)	120 (12m)	120 (12m)
Maximum Supply Pressure		
without ECV ⁶ fitted (kPa)	800 (680) ¹	330
with ECV ⁶ fitted (kPa)	680 (550) ¹	N/A

⁵ Figures in brackets are to be used if an RT stainless steel storage tank is utilised in the system.

⁶ Expansion control valve is not supplied with the water heater.

⁷ H models used for high temperature DHW applications follow pressure limitations of W models.

⁸ Lock band with screw required.

RAYPAK® ATMOSPHERIC HEATING AND HOT WATER

The industrial duty hot water system providing extreme durability.

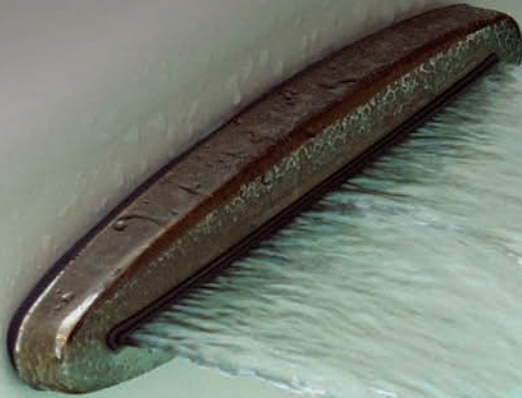

CASE STUDY

CROWN CASINO SYDNEY, NSW

Challenge

Sydney's Crown Casino at Barangaroo offers the ultimate in premium luxury facilities. The large hot water requirement is served by six separate zones, with each plantroom having their own unique temperature requirements and constraints.

Hot water solution

Multiple compact plant rooms each providing centralised hot water to separate zones in the building.

The combined plant includes:

- 4 x Raypak B3694 gas water heaters
- 2 x Raypak B4224 gas water heaters
- 2 x Raypak B1722 gas water heaters
- 2 x Raypak B0868 gas water heaters
- 2 x Raypak B0538 gas water heaters
- 2 x Rheem Tankpak TPI05NFD gas water heaters
- 7 x RT2000 stainless steel storage tanks
- 1 x RT1000 stainless steel storage tank
- 2 x Rheem 610430 storage tanks
- 7 x Guardian 940240 warm water units



RAYPAK® ATMOSPHERIC

FOR DOMESTIC HOT WATER AND HYDRONIC APPLICATIONS



GAS



IN MARKET



ROBUST CONSTRUCTION



FAST REPLACEMENT



THERMAL EFFICIENCY

Raypak® is a compact, efficient heating design which is the ideal way to heat large quantities of water for both hot water and hydronic applications.

HIGHLY RELIABLE

In the market for 50 years, Raypak's direct fired, bronze headers and pure copper-finned heat exchangers resist the combined effects of corrosion and high temperature.

CONSTANT HOT WATER AND HYDRONIC HEATING

Operating on mains pressure, on/off models deliver constant full recovery and modulating models respond to building load in low pressure heating circuits. On/Off models can operate as low as 41°C without any condensation or sooting.

FAST REPLACEMENT

The atmospheric combustion system and slide-out burner tray make it simple to maintain and repair, and the unit is readily deconstructed on site to allow for retrofit access.

HIGHLY EFFICIENT

Raypak's copper tube construction is highly responsive with an outstanding 82% thermal efficiency. The ceramic fibre refractory panels insulate the system with an interlocking design reducing heat loss. Add to this, high MJ/m² allowing for space saving installation flexibility.



WITHSTANDS HIGH TEMPERATURES

Robust materials mean modulating units can provide up to 90°C, ideal for sanitising and industrial process applications.

BMS CONNECTIVITY

Run and fail monitoring (available on Type B models).

MORE KEY FEATURES

- Selected models are available in propane
- Left hand(normal) or right hand water and gas connections available
- Water flow switch (Type B models)
- Heaters can be plumbed together for redundancy
- On/Off models suitable for domestic hot water applications
- Modulating models suitable for hydronic applications



*Conditions Apply: For full terms and conditions please contact Rheem or visit www.rheem.com.au/rheem/help/Warranties

TECHNICAL DATA

RAYPAK PIPE SIZE AND PUMP SELECTION CHART

Model	Pump UPS Series	Phase	Branch Size	Minimum Manifold Header Size/Pump Speed Required (mm)			
				1 Unit	2 Units	3 Units	4 Units
280	32-80N	1	32mm	32/3	32/3	50/3	65/3
350	32-80N	1	40mm	40/3	50/3	65/3	65/3
430	32-80N	1	40mm	40/3	50/3	65/3	80/3
538	32-80N	1	50mm	50/3	65/3	80/3	100/3
658	32-80N	1	50mm	50/3	80/3	80/3	100/3
768	40-60/2B	1	50mm	50/2	80/2	100/2	100/2
868	40-60/2B	1	65mm	65/2	80/2	100/2	100/3
972 / 992	40-60/2B	1	65mm	65/3	80/3	100/3	125/3
1142 / 1182	50-120FB	1	65mm	65/1	100/1	100/1	125/1
1242 / 1292	50-120FB	1	65mm	65/1	100/2	125/2	125/2
1362 / 1412	50-120FB	1	65mm	65/1	100/2	125/2	125/1
1662 / 1722	50-120FB	1	80mm	80/3	100/3	125/3	150/3
1852 / 1922	50-120FB	1	80mm	80/3	100/3	125/3	150/3
2004 / 2214	50-120FB	1	100mm	100/3	125/3	150/3	200/3
2404	50-120FB	1	100mm	100/3	125/3	150/3	200/3
2634	50-120FB	1	100mm	100/3	125/3	200/3	200/3
2804	65-150 FN	1	100mm	100/PP1	150 /PP1	200/PP1	200/PP1
3164	65-150 FN	1	100mm	100/PP1	150/PP1	200/PP1	200/PP1
3304	65-150 FN	1	100mm	125/PP1	150/PP1	200/PP1	200/PP1
3694	65-150 FN	1	125mm	125/PP1	200/PP1	200/PP1	-
3804	65-150 FN	1	125mm	125/PP1	200/PP1	200/PP2	-
4224	65-150 FN	1	125mm	125/PP1	200/PP1	-	-

NOTE: TP series circulator is recommended for hard water areas in lieu of UPS series circulator. Contact Rheem for further information.

Manifold header sizes are minimum requirements for water heater performance.

Pipe and pump sizing is for DHW only system up to 65°C maximum set point. Header pipe sizing is based on a total length of 20m of primary flow and return piping and 20 elbows, excluding equa-flow manifolds on storage tanks and Raypaks at 1.2m/sec velocity.

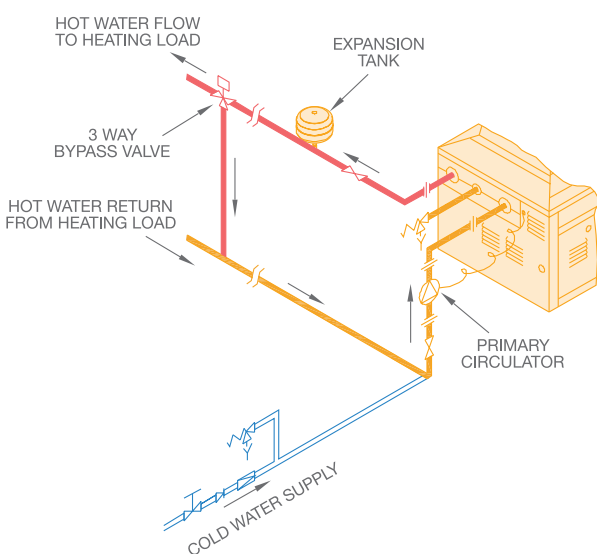

Single Mechanical Heating System

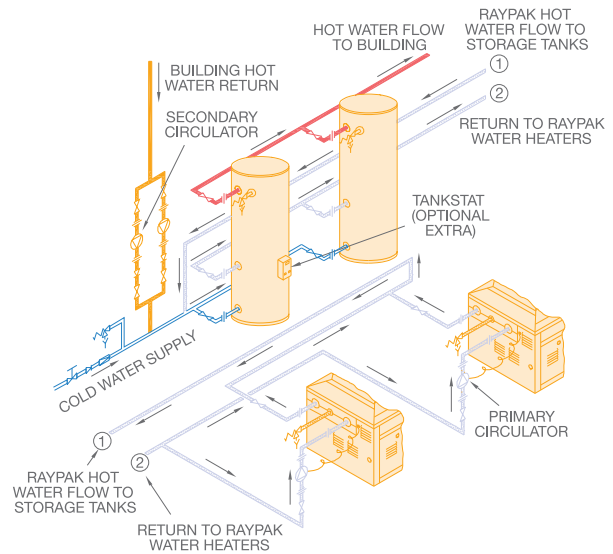

Double Domestic Hot Water System

TECHNICAL DATA

DIMENSIONS AND TECHNICAL DATA TABLE – INDOOR/OUTDOOR MODELS									
Model		200	280	350	430	538	658	768	868
Natural – Input	MJ/h	196	278	343	420	539	661	765	870
	kW	44	62	76	94	120	150	170	195
Propane – Input	MJ/h	185	261	323	396	–	620	–	–
	kW	41	58	72	88	–	140	–	–
Dimensions									
A	mm	1,625	1,715	1,715	1,805	–	–	–	–
B	mm	465	570	655	745	830	955	1,055	1,160
C	mm	1,955	2,240	2,035	2,145	2,130	2,255	2,255	2,355
Flue Connection	mm	175	205	225	255	255	305	305	355
Weight	kg	91	93	103	107	195	200	250	260
Inlet/Outlet Connections		RC1½	RC1½	RC1½	RC1½	RC2½	RC2½	RC2½	RC2½
Gas Connection									
Natural – On / Off Models		NA	RP¾	RP¾	RP¾	R1	R1½	R1½	R1½
Natural – Modulating Models		RP1	RP1	RP1	RP1	R1	R1	R1½	R1½
Propane – On / Off Models		NA	RP¾	RP¾	RP¾	–	–	–	–
Propane – Modulating Models		RP¾	RP¾	RP¾	RP¾	–	R¾	–	–
Relief Valve Connection									
On/Off models		NA	RC¾	RC¾	RC¾	RC¾	RC¾	RC¾	RC¾
Modulating models		RC¾	RC¾	RC¾	RC¾	RC¾	RC¾	RC¾	RC¾
Electrical Rating 240V 50Hz (excluding pump)	Watts	50	50	50	50	50	50	50	50
	Amps	0.21	0.21	0.21	0.21	0.21	0.21	0.21	0.21
Min. Buffer Tank Capacity	Litres	325	325	325	325	325	325	325	325
Max. Storage Capacity	Litres	2,000	3,000	4,000	4,800	6,000	7,500	8,500	10,000
Natural Gas									
Litres Recovery Per Hour @	30°C rise	1,250	1,769	2,187	2,683	3,440	4,300	4,873	5,590
	40°C rise	937	1,327	1,640	2,012	2,580	3,225	3,655	4,193
	50°C rise	750	1,061	1,312	1,610	2,064	2,580	2,924	3,354
	60°C rise	625	884	1,094	1,342	1,720	2,150	2,437	2,795
	65°C rise	577	816	1,010	1,238	1,588	1,985	2,249	2,580
	70°C rise	536	758	937	1,150	1,474	1,843	2,089	2,396
	75°C rise	500	708	875	1,073	1,376	1,720	1,949	2,236
	80°C rise	469	663	820	1,006	1,290	1,613	1,828	2,096
85°C rise	441	624	772	947	1,214	1,518	1,720	1,973	
Flow Rate and Pressure Drop									
Max. Flow Rate									
Modulating (10°C Rise) ¹	L/s	1.04	1.47	1.82	2.24	2.87	3.58	4.06	4.66
Pressure Drop	kPa	3	8	13	17	6	10	14	22
Max. Flow Rate									
On/Off (15°C Rise) ¹	L/s	0.69	0.98	1.22	1.49	1.91	2.39	2.71	3.11
Pressure Drop	kPa	3	4	6	8	3	4	6	8
Min. Flow Rate									
(20°C rise) ¹	L/s	0.52	0.74	0.91	1.12	1.43	1.79	2.03	2.33
Pressure Drop	kPa	3	3	3	4	3	3	4	5

¹ Guide only.

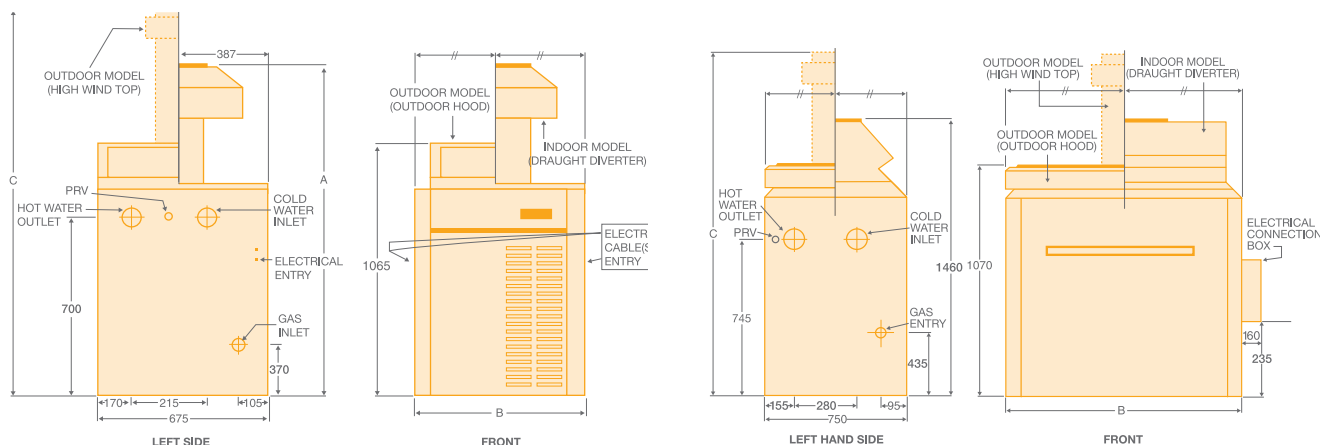

Models 200, 280, 350, 430 (Indoor/Outdoor)

Models 538, 658, 768 and 868 (Indoor/Outdoor)

TECHNICAL DATA

DIMENSIONS AND TECHNICAL DATA TABLE – INDOOR MODELS												
Model		992	1182	1292	1412	1722	1922	2214	2634	3164	3694	4224
Natural – Input	MJ/h	999	1,186	1,289	1,412	1,719	1,926	2,215	2,636	3,165	3,692	4,224
	– Output	kW	225	265	285	315	380	430	505	600	720	960
Propane – Input		933	–	–	1,296	–	1,772	–	–	–	–	–
	– Output		205	–	–	290	–	395	–	–	–	–
Dimensions												
A	mm	1,810	1,915	1,915	1,990	2,060	2,130	–	–	–	–	–
B	mm	1,330	1,510	1,615	1,740	2,070	2,270	1,550	1,780	2,060	2,350	2,640
G	mm	860	860	860	860	930	930	–	–	–	–	–
Flue Connection	mm	355	405	405	455	455	505	610	660	710	760	815
Weight	kg	310	330	360	390	440	460	625	700	780	860	940
Inlet/Outlet Connections		RC2½	RC2½	RC2½	RC2½	RC2½	RC2½	RC3	RC3	RC3	RC3	RC3
Gas Connection												
Natural – On / Off Models		R1½	R1½	R1½	R1½	R2	R2	R2	R2½	R2½	R3	R3
Natural – Modulating Models		R1½	R1½	R1½	R1½	R2	R2	R2	R2½	R2½	R3	R3
Propane – Modulating Models		R¾			R1		R1½					
Relief Valve Connection												
On/Off Models		RC¾	RC¾	RC¾	RC¾	RC¾	RC¾	RC¾	RC¾	RC1	RC1	RC1
Modulating Models		RC¾	RC¾	RC¾	RC¾	RC1	RC1	RC1¼	RC1¼	RC1½	RC1½	RC1½
Electrical Rating 240V 50Hz (excluding pump)	Watts	100	100	100	100	100	100	100	100	100	100	100
	Amps	0.42	0.42	0.42	0.42	0.42	0.42	0.42	0.42	0.42	0.42	0.42
Min. Buffer Tank Capacity	Litres	387	456	490	542	654	740	869	824	990	1,156	1,320
Max. Storage Capacity	Litres	11,000	13,000	14,500	16,000	19,500	22,000	27,000	31,000	37,000	43,500	49,500
Natural Gas												
Litres Recovery Per Hour @	30°C rise	6,450	7,597	8,170	9,030	10,893	12,327	14,477	17,200	20,640	24,080	27,520
	40°C rise	4,838	5,698	6,128	6,773	8,170	9,245	10,858	12,900	15,480	18,060	20,640
	50°C rise	3,870	4,558	4,902	5,418	6,536	7,396	8,686	10,320	12,384	14,448	16,512
	60°C rise	3,225	3,798	4,085	4,515	5,447	6,163	7,238	8,600	10,320	12,040	13,760
	65°C rise	2,977	3,506	3,771	4,168	5,028	5,689	6,682	7,939	9,526	11,114	12,702
	70°C rise	2,764	3,256	3,501	3,870	4,669	5,283	6,204	7,372	8,846	10,320	11,794
	75°C rise	2,580	3,039	3,268	3,612	4,357	4,931	5,791	6,880	8,256	9,632	11,008
	80°C rise	2,419	2,849	3,064	3,386	4,085	4,623	5,429	6,450	7,740	9,030	10,320
85°C rise	2,276	2,681	2,884	3,187	3,845	4,351	5,109	6,071	7,285	8,499	9,713	
Flow Rate and Pressure Drop												
Max. Flow Rate												
Modulating (10°C rise) ¹	L/s	5.38	6.31	6.31	6.31	6.31	6.31	12.06	12.62	12.62	12.62	12.62
Pressure Drop	kPa	29	44	46	49	55	58	48	49	50	54	57
Max. Flow Rate												
On/Off (15°C rise) ¹	L/s	3.58	4.22	4.54	5.02	6.05	6.31	8.04	9.56	11.47	12.62	12.62
Pressure Drop	kPa	12	18	24	30	51	58	20	28	38	54	57
Min. Flow Rate												
(20°C rise) ¹	L/s	2.69	3.17	3.40	3.76	4.54	5.14	6.03	7.17	8.60	10.03	11.47
Pressure Drop	kPa	7	11	14	18	30	39	12	17	23	30	42

¹ Guide only.

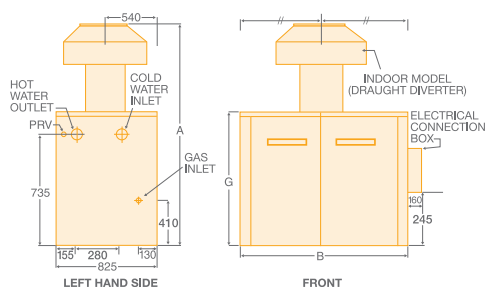

Models 992, 1182, 1292, 1412, 1722, 1922 (Indoor)

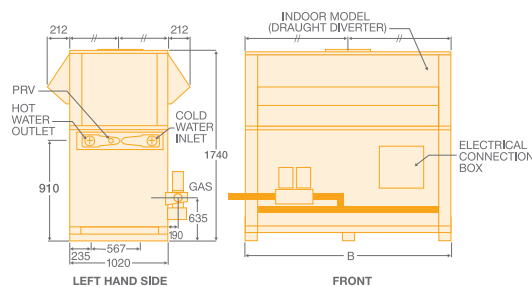

Models 2214, 2634, 3164, 3694, 4224 (Indoor)

TECHNICAL DATA

DIMENSIONS AND TECHNICAL DATA TABLE – OUTDOOR MODELS

Model		972	1142	1242	1362	1662	1852	2004	2404	2804	3304	3804
Natural – Input	MJ/h	976	1,142	1,242	1,357	1,657	1,854	2,004	2,404	2,804	3,304	3,804
	– Output	kW	220	255	275	300	370	410	445	530	625	740
Dimensions												
A	mm	2,500	2,395	2,395	2,570	2,640	2,920	3,165	3,210	3,185	2,965	3,165
B	mm	1,330	1,510	1,615	1,740	2,070	2,270	1,550	1,780	2,060	2,350	2,635
Weight	kg	360	385	410	440	510	520	650	730	810	890	970
Inlet/Outlet Connections		RC2½	RC2½	RC2½	RC2½	RC2½	RC2½	RC3	RC3	RC3	RC3	RC3
Gas Connection												
Natural – On / Off Models		R1½	R1½	R1½	R1½	R2	R2	R2	RC2½	RC2½	RC2½	R3
Natural – Modulating Models		R1½	R1½	R1½	R1½	R2	R2	R2	RC2½	RC2½	R3	R3
Propane – Modulating Models		R¾			R1		R1½					
Relief Valve Connection												
On/Off models		RC¾	RC¾	RC¾	RC¾	RC¾	RC¾	RC¾	RC¾	RC1	RC1	RC1
Modulating models		RC¾	RC¾	RC¾	RC¾	RC1	RC1	RC1½	RC1½	RC1½	RC1½	RC1½
Electrical Rating 240V 50Hz (excluding pump)	Watts	100	100	100	100	100	100	100	100	100	100	100
	Amps	0.42	0.42	0.42	0.42	0.42	0.42	0.42	0.42	0.42	0.42	0.42
Min. Buffer Tank Capacity	Litres	378	439	473	516	636	705	765	729	860	1,018	1,163
Max. Storage Capacity	Litres	11,000	13,000	14,000	15,500	19,000	21,000	23,000	27,000	32,000	39,000	43,000
Natural Gas												
Litres Recovery Per Hour @	30°C rise	6,307	7,310	7,883	8,600	10,607	11,753	12,757	15,194	17,917	21,214	24,224
	40°C rise	4,730	5,483	5,913	6,450	7,955	8,815	9,568	11,395	13,438	15,910	18,168
	50°C rise	3,784	4,386	4,730	5,160	6,364	7,052	7,654	9,116	10,750	12,728	14,534
	60°C rise	3,153	3,655	3,942	4,300	5,303	5,877	6,378	7,597	8,958	10,607	12,112
	65°C rise	2,911	3,374	3,639	3,969	4,895	5,425	5,888	7,012	8,269	9,791	11,180
	70°C rise	2,703	3,133	3,379	3,686	4,546	5,037	5,467	6,512	7,679	9,092	10,382
	75°C rise	2,523	2,924	3,153	3,440	4,243	4,701	5,103	6,077	7,167	8,485	9,689
	80°C rise	2,365	2,741	2,956	3,225	3,978	4,408	4,784	5,698	6,719	7,955	9,084
85°C rise	2,226	2,580	2,782	3,035	3,744	4,148	4,502	5,362	6,324	7,487	8,550	
Flow Rate and Pressure Drop												
Max. Flow Rate												
Modulating (10°C Rise) ¹	L/s	5.26	6.09	6.31	6.31	6.31	6.31	10.63	12.62	12.62	12.62	12.62
Pressure Drop	kPa	27	43	46	49	55	58	45	49	53	57	60
Max. Flow Rate												
On/Off (15°C Rise) ¹	L/s	3.50	4.06	4.38	4.78	5.89	6.31	7.09	8.44	9.95	11.79	12.62
Pressure Drop	kPa	12	18	23	30	49	58	18	28	35	53	57
Min. Flow Rate												
(20°C rise) ¹	L/s	2.63	3.05	3.28	3.58	4.42	4.90	5.32	6.33	7.47	8.84	10.09
Pressure Drop	kPa	7	10	12	16	27	21	12	17	21	30	42

¹ Guide only.

² Two high wind tops per model.

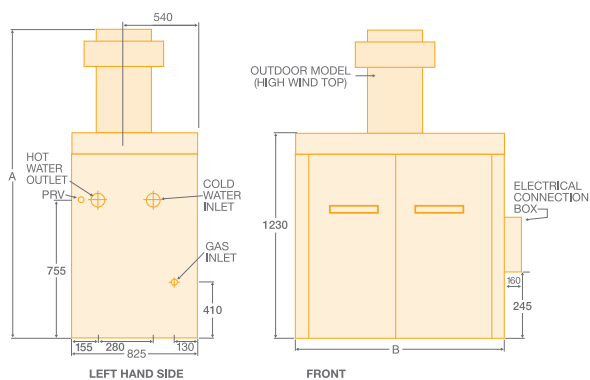

Models 972, 1142, 1242, 1362, 1662, 1852 (Outdoor)

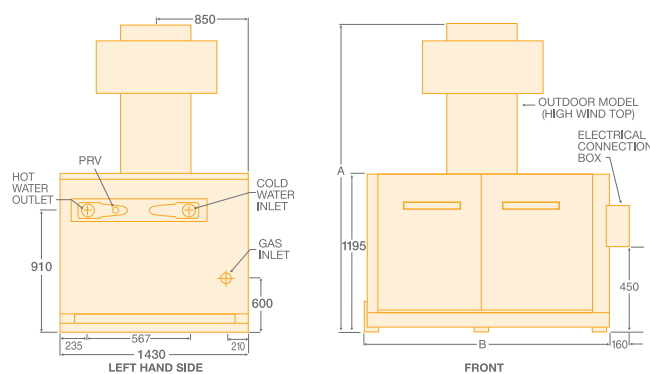

Models 2004, 2404, 2804², 3304², 3804² (Outdoor)

TECHNICAL DATA

ACCESSORIES FOR RAYPAK COMMERCIAL GAS WATER HEATERS

Accessories	Standard	Optional
Pump Run on Timer	All modulating	All On/Off
Tankstat	–	200 to 4224
Hot Surface Ignition (HSI)	200 to 430	–
Electronic Ignition	538 to 4224	–
Water Flow Switch	538 to 4224	–
Relay Run and Fault Status	538 to 4224	–
High Wind Top (outdoor installations only)	538 to 3804	200 to 430
Left Hand Water and Gas Connections	200 to 4224	–
Right Hand Water Connections	–	200 to 430
Right Hand Water and Gas Connections	–	538 to 4224

MINIMUM SUPPLY PRESSURE

System design and pump selection is critical when water heaters are connected to a low pressure water supply. Refer to the table below for minimum pressure requirements for Grundfos UPS series pumps. Minimum pressure requirements for TP series pumps depend on system characteristics and need to be calculated. Contact your pump supplier for details.

Pump	Model	Minimum Inlet Pressure Required (m) at Operating Temperature				
		75°C	80°C	85°C	90°C	95°C
UPS32-80N	280, 350, 430, 538, 658	0.5	0.5	0.5	3.0	5.0
UPS40-60/2B	768, 868, 972, 992	1.5	2.5	3.5	4.5	7.0
UPS50-120FB	1142, 1182, 1242, 1292, 1362, 1412, 1662, 1722, 1852, 1922, 2004, 2214, 2404, 2634	4.0	5.0	6.0	7.0	9.0
Magna1 65-150	2804, 3164, 3304, 3694, 3804, 4224	8	9	10	11.5	13

WATER SUPPLY AND RELIEF VALVE SETTINGS

Burner Type			On/Off	Modulating	
			All	200–430	538–4224
Models					
Relief Valve Setting					
Potable Hot Water	kPa	850	850 ⁵	850 ⁵	850 ⁵
Mechanical Heating	kPa	–	310	415	
Expansion Control Valve (ECV ⁴) Setting					
Potable Hot Water	kPa	700	700 ⁵	700 ⁵	700 ⁵
Mechanical Heating	kPa	–	–	–	–
Maximum Supply Pressure without ECV ⁴ fitted					
Potable Hot Water	kPa	680	680 ⁵	680 ⁵	680 ⁵
Mechanical Heating	kPa	–	240	330	
with ECV ⁴ fitted					
Potable Hot Water	kPa	550	550 ⁵	550 ⁵	550 ⁵
Mechanical Heating	kPa	–	–	–	–



Raypak® indoor gas water heaters are designed for connection to a flue system in accordance with the requirements of AS/NZS 5601.1.

TECHNICAL DATA

RAYPAK MODEL NUMBERS

The following information should be supplied when ordering Raypak water heaters

B	0430	N	C	O	/	ID
Water	Approx	N = Natural Gas	Copper Heat	O = On/Off		ID = Indoor
Heater	Thermal Input*	P = Propane	Exchanger	M = Modulating		HWT = High Wind Top

NOTE: *last digit designates series type.

GAS PRESSURE			200-430	538-4224
Natural	Minimum	kPa	1.13	1.13
	Test Point	kPa	0.77	0.92
	Maximum	kPa	3.50	4.00
Propane	Minimum	kPa	2.75	2.75
	Test Point	kPa	2.75	2.75
	Maximum	kPa	3.50	4.00

THERMOSTAT SETTINGS			
Modulating	Maximum	°C	95
	Factory set	°C	78
	Minimum	°C	44
On/Off	Maximum	°C	80
	Factory set	°C	50
	Minimum	°C	44

CLEARANCES COMBUSTIBLES (mm) ³					
Model	Back	Front	Left	Right	Ceiling
200 to 430	500	750	600	500	1,200
538 to 1922	600	750	600	600	1,200
2004 to 4224	600	1,200	600	600	1,200

CLEARANCES NON COMBUSTIBLES (mm) ³					
Model	Back	Front	Left	Right	Ceiling
200 to 430	150	750	600	150	1,200
538 to 1922	150	750	600	600	1,200
2004 to 4224	300	1,200	600	600	1,200

³ Excludes flue terminal clearances. Refer to AS/NZS 5601.1.

⁴ Expansion Control Valve is not supplied with the water heater.

⁵ An 850kPa relief valve can be fitted to modulating water heaters used in potable hot water applications.



HEAVY DUTY ELECTRIC

The robust, vitreous enamel, hot water system for durability in a wider range of water quality environments.



CASE STUDY

CALVARY HOSPITAL BRUCE, ACT

Challenge

Calvary Hospital management decided to upgrade the hot water systems for the 6 Operations Zones, each having specific requirements for a mixture of operating theatres, birth suits, general ward, kitchen or cafeteria and short stay accommodation for RMO's and Nursing Staff.

Hot water solution

The sustainable solution included Air to Water Heat Pumps and a combination

of RT Series Storage Tanks with Commercial Electric Heating Units for in tank boosting when low ambient conditions are present.

Total hot water plant installed included:

- 16 x 953022 - 16kW Air to Water Heat Pumps
- 9 x 1000 litre RT1000 stainless steel storage tanks, each with 15kW Commercial Electric Heating Units
- 5 x 2000 litre RT2000 stainless steel storage tanks, each with 30kW Commercial Electric Heating Units



HEAVY DUTY ELECTRIC

FOR SMALL TO LARGE APPLICATIONS



ELECTRIC



DOUBLE COATED ENAMEL



LARGER ANODE



UP TO 36kW



HIGH PRESSURE

Designed for large scale commercial applications and most water chemistries.

IMPERVIOUS TO ALL KINDS OF WATER

Made from a special grade of steel, lined with a double coat of heavy duty vitreous enamel and incorporates a larger anode.

NEVER LOSE PRESSURE

Heavy Duty Electric uses true multipoint operation through large 32mm connections with no exchange coils to restrict pressure or flow and it can be used with low pressure systems if needed.

MORE KEY FEATURES

- Suitable for either indoor or outdoor installation
- Up to 36kW providing plenty of hot water
- Trade adjustable thermostats suitable for sanitizing
- A bank of 8 x 616 315 Rheem commercial electric water heaters can deliver up to 7,480 litres of hot water in the first hour



*Conditions Apply: For full terms and conditions please contact Rheem or visit www.rheem.com.au/rheem/help/Warranties



TECHNICAL ELECTRIC PERFORMANCE DETAILS							
Heating Elements		3 x 3.6 kW	3 x 4.8 kW	3 x 6.0 kW	6 x 3.6 kW	6 x 4.8 kW	6 x 6.0 kW
Total Input	kW	10.8	14.4	18.0	21.6	28.8	36.0
Current (per phase)	Amps	15	20	25	30	40	50
Litres Recovery Per Hour at Rise of	20°C	460	620	770	930	1240	1550
	30°C	310	410	520	620	830	1030
	40°C	230	310	390	460	620	770
	50°C	190	250	310	370	500	620
	60°C	150	210	260	310	410	520
	65°C	140	190	240	290	380	480
	70°C	130	180	220	270	350	440
75°C	120	170	210	250	330	410	

NOTE: Figures rounded to the nearest 10 litres.

TECHNICAL DATA

DIMENSIONS AND TECHNICAL DATA TABLE INDOOR/OUTDOOR MODELS					
Model			613 050	613 315	616 315
Storage Capacity		Litres	60	325	325
Delivery Rating		Litres	50	315	315
Dimensions	A	mm	675	1640	1640
	B	mm	436	638	638
	C	mm	476	678	678
	D	mm	405	1294	1294
	E	mm	90	128	128
	F	mm	80	130	130
	H	Degrees	30°	32°	32°
J	Degrees	90°	90°	90°	
Weight – Empty		kg	34	96	98
Inlet/Outlet Connections (BSPF)			RP1¼	RP1¼	RP1¼
T&PR Valve Connection (BSPF)			RP¾	RP¾	RP¾
T&PR Valve Setting		kPa	1000	1000	1000
Expansion Control Valve (ECV) ¹ Setting		kPa	850	850	850
Max. Water Supply Pressure		kPa	800	800	800
	without ECV ¹ fitted	kPa	680	680	680
Factory Thermostat Setting		°C	70	70	70
Min. Thermostat Setting		°C	60	60	60
Manifold – Min. Centre to Centre		mm	685	890	890
Electrical Connection			three phase	three phase	three phase
	415V				
Heating Elements		kW	3 x 3.6	3 x 3.6	6 x 3.6
		or	3 x 4.8	3 x 4.8	6 x 4.8
		or	–	3 x 6.0	6 x 6.0

¹ Expansion control valve not supplied with the water heater.

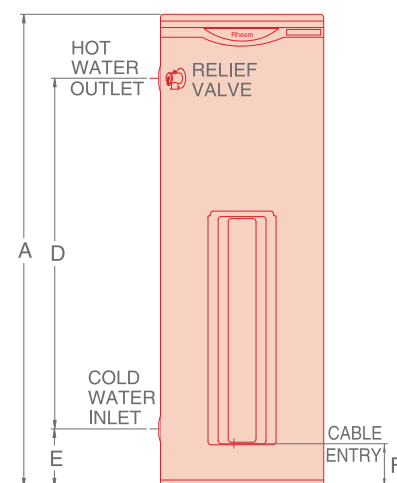

Side view

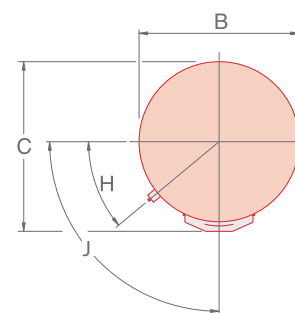

Plan view

APPROXIMATE DAILY ENERGY CONSUMPTION				
Daily Hot Water Usage @ 50°C Temp Rise (Litres)	Energy Content of Hot Water (kWh)	RHEEM COMMERCIAL ELECTRIC WATER HEATERS		
		Approximate Energy Used Per Day (kWh)		
		613 050	613 315	616 315
0	0.0	1.8	3.1	3.2
50	2.9	4.7	6.0	6.1
100	5.8	7.6	8.9	9.0
150	8.7	10.5	11.8	11.9
200	11.6	13.4	14.7	14.8
250	14.5	16.3	17.6	17.7
300	17.4	19.2	20.5	20.6
350	20.3	22.1	23.4	23.5
400	23.3	25.1	26.4	26.5
450	26.2	28.0	29.3	29.4
500	29.1	30.9	32.2	32.3
600	34.9	36.7	38.0	38.1
700	40.7	42.5	43.8	43.9
800	46.5	48.3	49.6	49.7
900	52.3	54.1	55.4	55.5
1000	58.1	59.9	61.2	61.3
1250	72.7	74.5	75.8	75.9
1500	87.2	89.0	90.3	90.4
1750	101.7	103.5	104.8	104.9
2000	116.3	118.1	119.4	119.5
2500	145.3	–	148.4	148.5
3000	174.4	–	–	177.6
3500	203.5	–	–	206.7
4000	232.6	–	–	235.8
5000	290.7	–	–	293.9

TECHNICAL DATA

PERFORMANCE DATA										
Model	No. of Units in Parallel	Initial Delivery (Litres)	Heating Elements (kW)	Total Kilowatts	Available Litres of Hot Water at 50°C Temperature Rise Over Peak Period					
					1 Hour	2 Hours	3 Hours	4 Hours	6 Hours	8 Hours
613 050	1	50	3 x 3.6	10.8	240	420	610	790	1160	1540
			3 x 4.8	14.4	300	550	790	1040	1540	2030
613 315	1	315	3 x 3.6	10.8	500	690	870	1060	1430	1800
			3 x 4.8	14.4	560	810	1060	1310	1800	2300
			3 x 6.0	18.0	620	930	1240	1550	2170	2790
	2	630	3 x 3.6	21.6	1000	1370	1740	2120	2860	3600
			3 x 4.8	28.8	1130	1620	2120	2610	3600	4590
			3 x 6.0	36.0	1250	1870	2490	3110	4350	5580
	3	945	3 x 3.6	32.4	1500	2060	2620	3170	4290	5400
			3 x 4.8	43.2	1690	2430	3170	3920	5400	6890
			3 x 6.0	54.0	1870	2800	3730	4660	6520	8380
616 315	1	315	6 x 3.6	21.6	690	1060	1430	1800	2540	3290
			6 x 4.8	28.8	810	1310	1800	2300	3290	4280
			6 x 6.0	36.0	930	1550	2170	2790	4030	5270
	2	630	6 x 3.6	43.2	1370	2120	2860	3600	5090	6570
			6 x 4.8	57.6	1620	2610	3600	4590	6570	8560
			6 x 6.0	72.0	1870	3110	4350	5580	8060	10540
	3	945	6 x 3.6	64.8	2060	3170	4290	5400	7630	9860
			6 x 4.8	86.4	2430	3920	5400	6890	9860	12830
			6 x 6.0	108.0	2800	4660	6520	8380	12090	15810
	4	1260	6 x 3.6	86.4	2750	4230	5720	7200	10180	13150
			6 x 4.8	115.2	3240	5220	7200	9190	13150	17110
			6 x 6.0	144.0	3740	6210	8690	11170	16120	21070
5	1575	6 x 3.6	108.0	3430	5290	7150	9010	12720	16440	
		6 x 4.8	144.0	4050	6530	9010	11480	16440	21390	
		6 x 6.0	180.0	4670	7770	10860	13960	20150	26340	
6	1890	6 x 3.6	129.6	4120	6350	8580	10810	15260	19720	
		6 x 4.8	172.8	4860	7830	10810	13780	19720	25670	
		6 x 6.0	216.0	5610	9320	13040	16750	24180	31610	
Model	No. of Units in Parallel	Initial Delivery (Litres)	Heating Elements (kW)	Total Kilowatts	Available Litres of Hot Water at 65°C Temperature Rise Over Peak Period					
					1 Hour	2 Hours	3 Hours	4 Hours	6 Hours	8 Hours
613 050	1	50	3 x 3.6	10.8	190	340	480	620	910	1190
			3 x 4.8	14.4	240	430	620	810	1190	1570
613 315	1	315	3 x 3.6	10.8	460	600	740	890	1170	1460
			3 x 4.8	14.4	510	700	890	1080	1460	1840
			3 x 6.0	18.0	550	790	1030	1270	1740	2220
	2	630	3 x 3.6	21.6	920	1200	1490	1770	2340	2920
			3 x 4.8	28.8	1010	1390	1770	2150	2920	3680
			3 x 6.0	36.0	1110	1580	2060	2540	3490	4440
3	945	3 x 3.6	32.4	1370	1800	2230	2660	3520	4370	
		3 x 4.8	43.2	1520	2090	2660	3230	4370	5520	
		3 x 6.0	54.0	1660	2370	3090	3800	5230	6660	
616 315	1	315	6 x 3.6	21.6	600	890	1170	1460	2030	2600
			6 x 4.8	28.8	700	1080	1460	1840	2600	3360
			6 x 6.0	36.0	790	1270	1740	2220	3170	4130
	2	630	6 x 3.6	43.2	1200	1770	2340	2920	4060	5200
			6 x 4.8	57.6	1390	2150	2920	3680	5200	6730
			6 x 6.0	72.0	1580	2540	3490	4440	6350	8250
	3	945	6 x 3.6	64.8	1800	2660	3520	4370	6090	7800
			6 x 4.8	86.4	2090	3230	4370	5520	7800	10090
			6 x 6.0	108.0	2370	3800	5230	6660	9520	12380

NOTE: Figures rounded to the nearest 10 litres.

COMMERCIAL ELECTRIC HEATING UNIT

FOR LARGE SCALE APPLICATIONS USING RT STORAGE TANKS



ELECTRIC



HIGHLY DURABLE



6 SIZES 15-100kW



UP TO 1,700L/hr RECOVERY

The long life, large scale, electric water heating unit.

HIGHLY DURABLE

Element sheath made of Incoloy 800 and low watt heating density of less than 0.6W/cm². Add to this an IP65-rated 304 grade stainless steel electrical enclosure, 316L stainless steel flange plate with EPDM gasket and sun shield. Also manufactured with long-life components, like the AC3-rated contactor, providing over 1,000,000 cycles.

HIGH CAPACITY

Available in six sizes from 15kW up to 100kW providing a huge heating capacity up to 1,700L/hr recovery raised 50°C and tank capacity ranges from nominal 1000 to 5000 litres.

FUEL REDUNDANCY

Can be interlocked with other fuel source water heaters, for example timer or thermostatically controlled, to maximise the solar contribution factor (SCF) or ensure hot water supply in low ambient conditions with heat pumps.

MORE KEY FEATURES

- Thermostat has visual temperature display and can be user-set up to 83°C
- When coupled with the Rheem RT Series of large capacity stainless steel or carbon steel storage tanks, the heating unit can be placed in the upper or lower tank flange, with the upper flange providing solar or heat pump boost options or the lower flange being used as a stand-alone electric water heater.

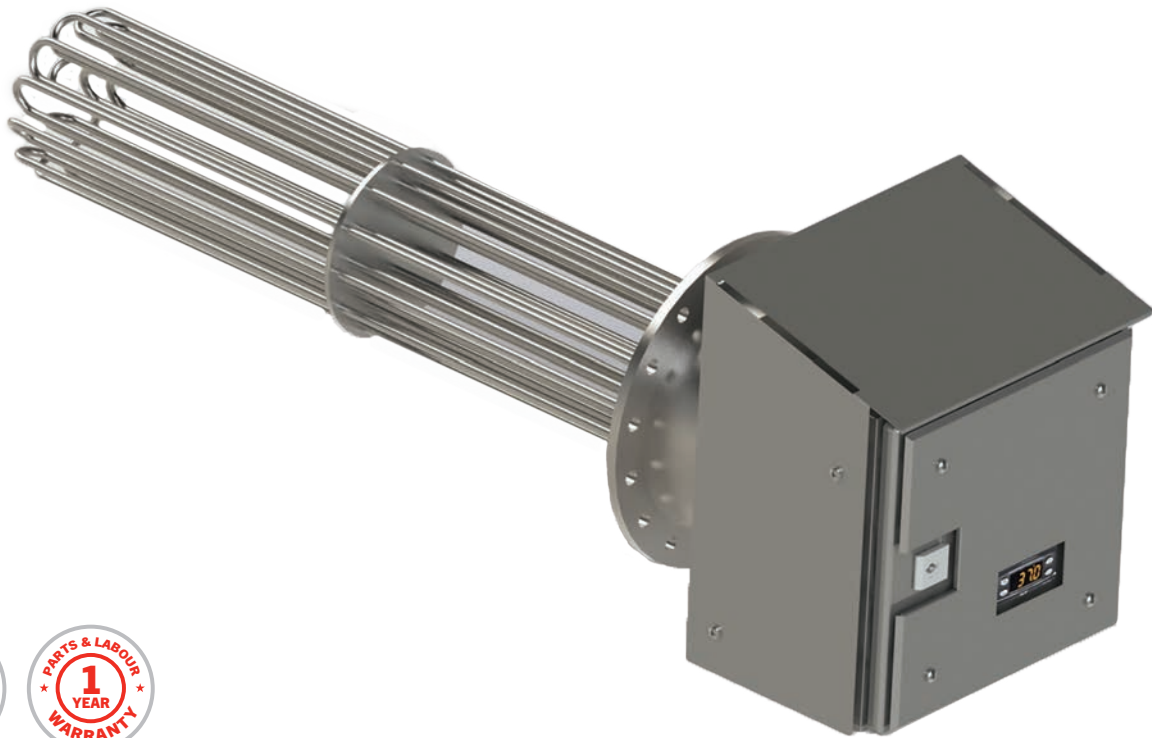

*Conditions Apply: For full terms and conditions please contact Rheem or visit www.rheem.com.au/rheem/help/Warranties

TECHNICAL DATA

DIMENSIONS AND TECHNICAL DATA TABLE								
Model		050350	050351	050352	050353	050354	050355	
Nominal Rating	kW	15	30	45	60	75	100	
Electrical Rating		380 - 415 V AC 50/60Hz Star Connected					380 - 415 V AC 50/60Hz Delta Connected	
Recovery Rate (50°C Rise)	L/hr	258	516	774	1032	1290	1720	
Current per Phase	Amps	21	42	63	83	104	139	
Factory Setting	°C	70	70	70	70	70	70	
Max. Thermostat Setting	°C	83	83	83	83	83	83	
ECO Setting	°C	90	90	90	90	90	90	
Cabinet Width (A)	mm	300	300	300	300	400	400	
Cabinet Height (B)	mm	300	300	300	300	400	400	
Cabinet Depth (C)	mm	218	218	218	218	248	248	
Exposed Length (D)	mm	316	316	316	316	346	346	
Immersed Length (L)	mm	750	750	750	750	750	1250	
Weight (packaged)	kg	47.5	48.2	49	49.8	50.7	53.6	
Suitable RT Series Tank		1000 – 5000	1000 – 5000	1000 – 5000	1000 – 5000	1000 – 5000	3000 – 5000	

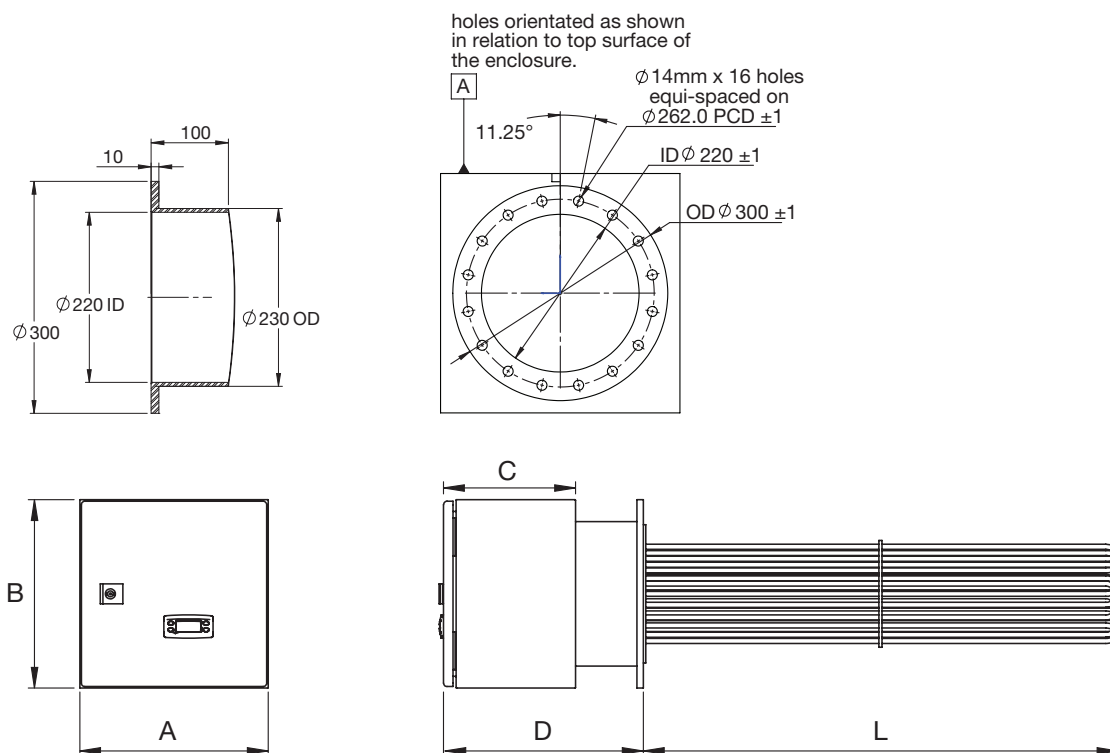

COMMERCIAL HEAT PUMP

Heat water using free energy from the air using our Air to Water models, or, heat water using waste heat from a chiller using our Water to Water models.

CASE STUDY

CURTIN UNIVERSITY PERTH, WA

Challenge

Western Australia's Curtin University has embarked on the delivery of their Master Plan, which will transform the Perth campus into a collaborative innovation precinct.

To reduce ongoing operational and running costs Stantec chose to work with Rheem on a central plant system.

By installing high efficiency Rheem Air to Water Commercial Heat Pumps, the

"Exchange" building achieved 6 Star certification.

Hot Water Solution

Across the entire precinct, Rheem supplied:

- 4 x Rheem 35kW Air to Water Commercial Heat Pumps
- 4 x Rheem 16kW Air to Water Commercial Heat Pumps
- 4 x BMS monitoring
- 29 x Rheem 1000L RT Series Storage Tanks
- 3 x Rheem Tankpak Deluxe gas water heaters



AIR TO WATER HEAT PUMP

FOR WHERE ENERGY EFFICIENCY IS ESSENTIAL



HEAT PUMP

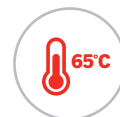

HOT WATER TO 65°C¹



SAVE UP TO 75% ENERGY



FLEXIBLE, USES CAR PARK AIR

65°C hot water in a super-efficient, super-compact package.

HIGHLY EFFICIENT

On average, 25% of the operating cost of an electric water heater. Delivers hot water up to 65°C¹, with a system Coefficient of Performance (COP) of up to 4.2². This makes it substantially cheaper to run than electric, natural gas or propane. Highly efficient option for fuel redundancy. Heat pumps can also be used as a preheat to other boost fuel types.

GREEN POINTS

Adds to the green points from End of Trip Facilities. The heat pump is designed to draw it's air from and discharge within basement car parks without flueing, unlike gas systems therefore reducing CO₂ emissions.

MULTIPLE INSTALLATION OPTIONS

Designed for both vertical or horizontal discharge options, with a discharge fan option available in both ducted and non-ducted versions. Horizontal discharge models can also be stacked two high to reduce plant footprint (suffix 'S').

SUITS MOST AUSTRALIAN CLIMATES

Manufactured by Rheem in Australia and supported by a nationwide in-house Service team, with local technical support. Automatic defrost allows continued performance in low ambient temperature conditions by diverting a portion of the hot refrigerant to the evaporator coil to melt any ice which may form. In addition, the evaporator

is fully dipped with Rheem Kote® to provide extra protection in corrosive atmospheres, and the unit has been tested in ambient conditions as high as 45°C.

- Rheem iQ control provides on board diagnostics, system configuration and optional high level BMS connectivity via Modbus or BACnet



Typical installation

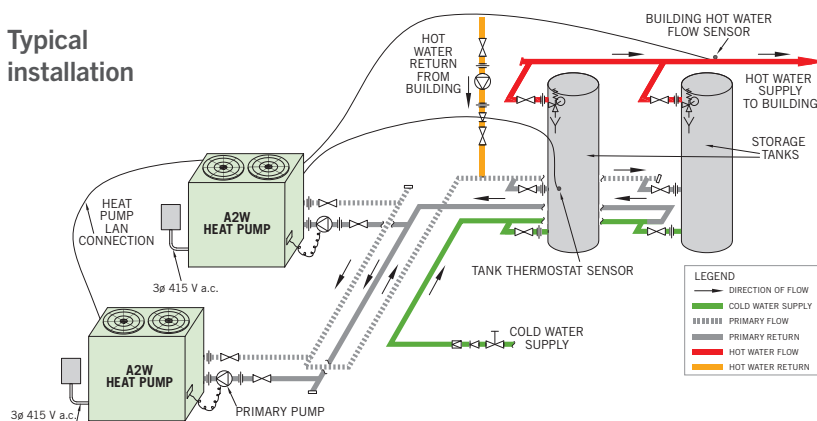

*Conditions Apply: For full terms and conditions please contact Rheem or visit www.rheem.com.au/rheem/help/Warranties



TECHNICAL DATA

AIR TO WATER 16kW MODEL

Horizontal Discharge Models

- 953016H0 – Non Ducted
- 953016HS – Non Ducted stackable
- 952016H0 – Ducted
- 952016HS – Ducted stackable

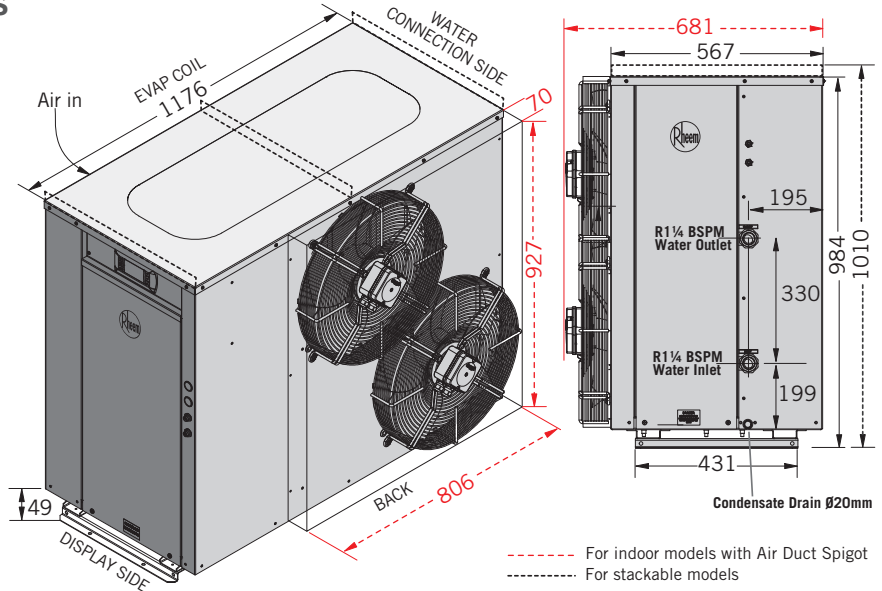

Vertical Discharge Models

- 95301600 – Non Ducted
- 95201600 – Ducted

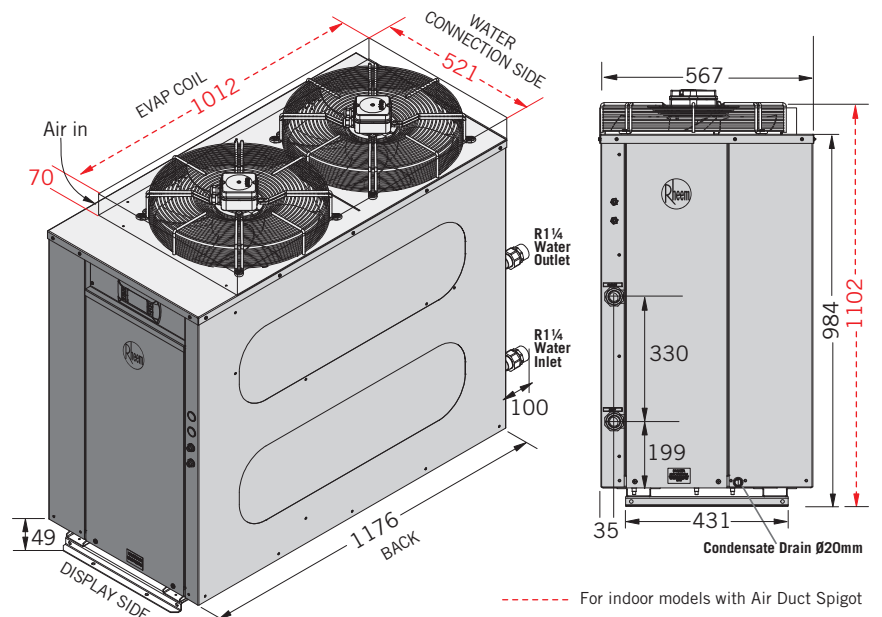

TECHNICAL DATA

AIR TO WATER 16KW MODEL			
Product data		Ducted Exhaust	Non Ducted Exhaust
Heating Capacity ²	kW	17.83	17.83
Power Input ²	kW	4.26	4.26
Coefficient of Performance COP ²		4.2	4.2
Recovery @ 50°C Rise ²	L/hr	300	
Operating Range (ambient)	°C	0-45	
Maximum DHW Temperature	°C	65	
Refrigerant		R134a	
Hot Water Side			
TPR Valve Setting (VE/RT)	kPa	1,000/850	
ECV Setting (VE/RT) ³	kPa	850/700	
Maximum Water Supply Pressure			
- Without ECV (VE/RT)	kPa	800/680	
- With ECV (VE/RT)		650/550	
Design Flow Rate	L/s	1.1	
Design Pressure Drop	kPa	33	
Heat Exchanger Design		316 Stainless Steel DWBP	
Air Side			
Air Flow (at maximum static pressure)	L/s	1600	
Maximum Static Pressure	Pa	92	5
Minimum Ventilation per inlet or outlet (with cross flow ventilation)	each m ²	2	
Electrical Connection			
Power Supply		3 Phase / 380-415V / 50 Hz	
Max Current per Phase (running, incl pump)	Amps	17.06	15.22
Minimum Circuit Breaker size (per phase)	Amps	20	
Installation Data			
Approx Weight Empty	kg	120	
Approx Weight Full	kg	125	
Storage per Heat Pump	L	400 – 4,000	
Sound Pressure Level	dBa	56 @ 3m	
Clearances			
Evap Coil Side	mm	500	
Back (vertical discharge models)	mm	Nil	
Back (horizontal discharge models)	mm	1,200	
Display Side	mm	850	
Water Connection Side	mm	500	
Top (vertical discharge models)	mm	1,200	
Top (horizontal discharge models)	mm	Clearance above unit required for service personnel to stand	

PUMP AND PIPE SIZING CHART				
Number of Heat Pumps in Parallel	1	2	3	4
Primary Pump	CM3-2			
Branch Size	40			
Header Size	40	50	65	80

Note: Header pipe sizing is based on a total length of 40m of primary flow and return piping and 20 bends, excluding equa-flow manifolds on storage tanks and heat pumps @ 1.2m/sec velocity. One pump per Heat Pump.

ACCESSORIES			
Storage Tank	Pump	BMS Card	LAN Cable
410L (VE)	CM 3-2 366084	17520 BACnet TCP/IP	17534
1000L to 5000L (SS)		17521 BACnet MS/TP	
		17522 Modbus RS485	

¹ When ambient temperature is not likely to drop below 10°C during operation.

² 20°C ambient/60%RH. 39°C water in / 45°C water out.

³ ECV not supplied with water heater.

TECHNICAL DATA

AIR TO WATER 35kW MODEL

Horizontal Discharge Models

- 953035H0 – Non Ducted
- 953035HS – Non Ducted stackable
- 952035H0 – Ducted
- 952035HS – Ducted stackable

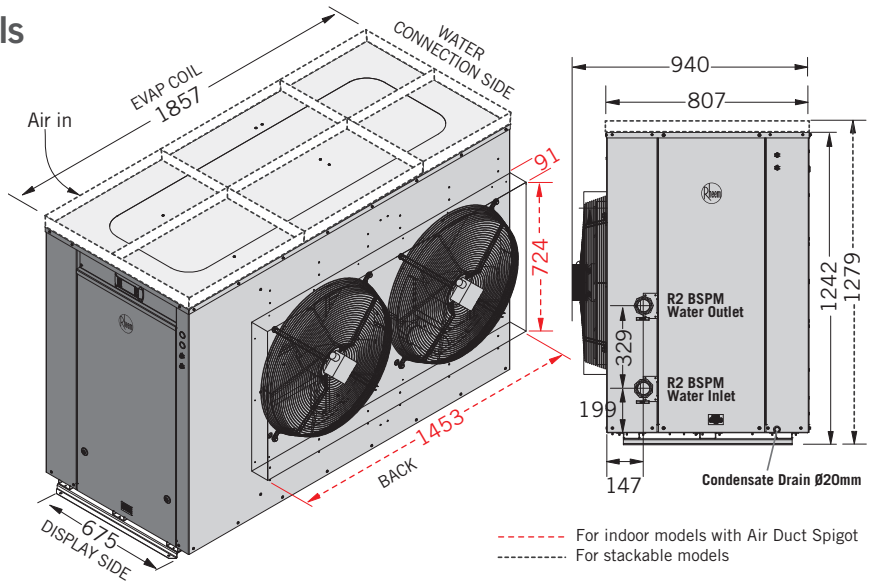

Vertical Discharge Models

- 95303500 – Non Ducted
- 95203500 – Ducted

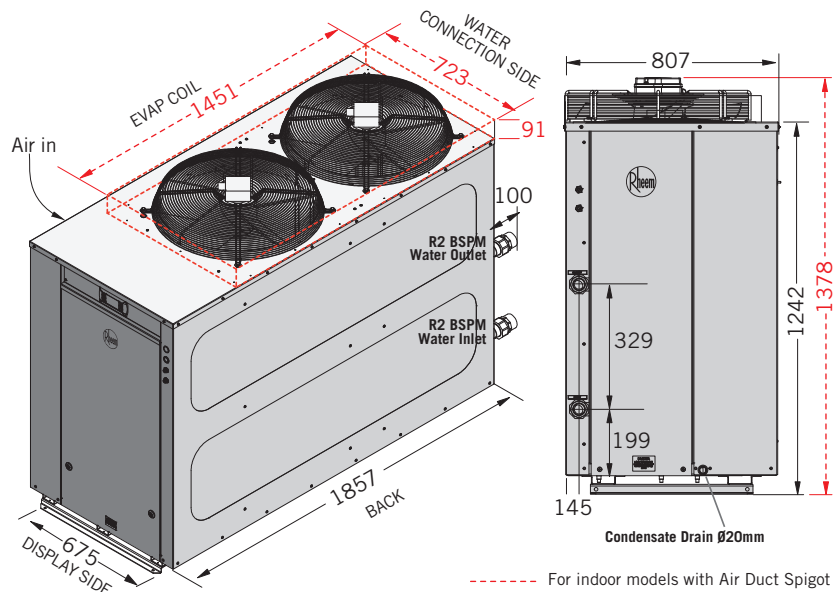

TECHNICAL DATA

AIR TO WATER 35KW MODEL			
PRODUCT DATA		Ducted Exhaust	Non Ducted Exhaust
Heating Capacity ²	kW	39.55	39.55
Power Input ²	kW	10.25	10.25
Coefficient of Performance COP ²		3.9	3.9
Recovery @ 50°C Rise ²	L/hr		680
Operating Range (ambient)	°C		0-45
Maximum DHW Temperature	°C		65
Refrigerant			R134a
Hot Water Side			
TPR Valve Setting (VE/RT)	kPa		1,000/850
ECV Setting (VE/RT) ³	kPa		850/700
Maximum Water Supply Pressure	kPa		
- Without ECV (VE/RT)			800/680
- With ECV (VE/RT)			650/550
Design Flow Rate	L/s		2.2
Design Pressure Drop	kPa		40
Heat Exchanger Design			316 Stainless Steel DWBP
Air Side			
Air Flow (at maximum static pressure)	L/s	5,830	5,270
Maximum Static Pressure	Pa	126	5
Minimum Ventilation per inlet or outlet (with cross flow ventilation)	each m ²		4
Electrical Connection			
Power Supply			3 Phase / 380-415V / 50 Hz
Max Current per Phase (running, incl pump)	Amps	34.9	32.34
Minimum Circuit Breaker size (per phase)	Amps		40
Installation Data			
Approx Weight Empty	kg		300
Approx Weight Full	kg		310
Storage per Heat Pump	L		400 – 8,000
Sound Pressure Level	dBa		64 @ 3m
Clearances			
Evap Coil Side	mm		1,000
Back (vertical discharge models)	mm		Nil
Back (horizontal discharge models)	mm		2,000
Display Side	mm		850
Water Connection Side	mm		600
Top (vertical discharge models)	mm		2,000
Top (horizontal discharge models)	mm		Clearance above unit required for service personnel to stand

PUMP AND PIPE SIZING CHART				
Number of Heat Pumps in Parallel	1	2	3	4
Primary Pump	Grundfos CM 10-1			
Branch Size	50			
Header Size	50	80	100	100

Note: Header pipe sizing is based on a total length of 40m of primary flow and return piping and 20 bends, excluding equa-flow manifolds on storage tanks and heat pumps @ 1.2m/sec velocity. One pump per Heat Pump.

ACCESSORIES			
Storage Tank	Pump	BMS Card	LAN Cable
410L (VE)	CM 10-1 366094	17520- BACnet TCP/IP	17534
1000L to 5000L (SS)		17521- BACnet MS/TP	
		17522- Modbus RS485	

¹ When ambient temperature is not likely to drop below 10°C during operation.

² 20°C ambient/60%RH. 39°C water in / 45°C water out.

³ ECV not supplied with water heater.

TECHNICAL DATA

AIR TO WATER 16KW MODEL RECOVERY

Ambient Temperature °C	0	5	10	15	20	25	30	35	40	45
Output (kW)	11.18	12.85	14.51	16.17	17.83	19.76	21.69	23.62	25.55	27.48
Recovery – Litres per hour										
20°C rise	481	553	624	695	767	850	933	1016	1099	1182
25°C rise	385	442	499	556	613	680	746	813	879	945
30°C rise	320	368	416	464	511	566	622	677	732	788
35°C rise	274	315	356	397	438	485	532	580	627	675
40°C rise	240	276	312	348	383	425	466	508	549	591
45°C rise	214	246	277	309	341	378	415	451	488	525
50°C rise	N/A	221	250	278	307	340	373	406	439	473
55°C rise	N/A	201	227	253	279	309	339	369	400	430

AIR TO WATER 35KW MODEL RECOVERY

Ambient Temperature °C	0	5	10	15	20	25	30	35	40	45
Output (kW)	22.63	26.60	29.07	33.96	39.55	46.04	49.05	52.11	54.57	56.28
Recovery – Litres per hour										
20°C rise	973	1144	1250	1460	1701	1980	2109	2241	2347	2420
25°C rise	778	915	1000	1168	1361	1584	1687	1793	1877	1936
30°C rise	649	763	833	974	1134	1320	1406	1494	1564	1613
35°C rise	556	654	714	834	972	1131	1205	1280	1341	1383
40°C rise	487	572	625	730	850	990	1055	1120	1173	1210
45°C rise	432	508	556	649	756	880	937	996	1043	1076
50°C rise	N/A	458	500	584	680	792	844	896	939	968
55°C rise	N/A	416	455	531	618	720	767	815	853	880

16 kW A2W COP and Heating Capacity

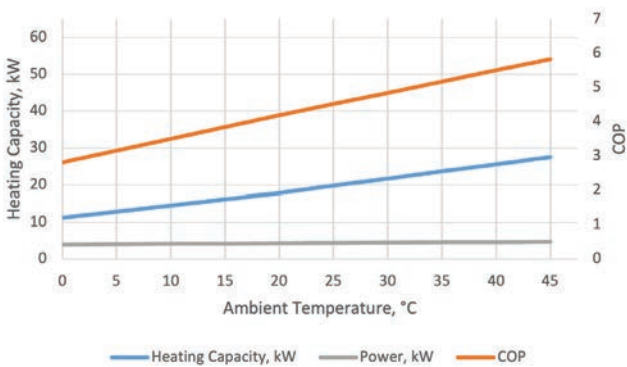

35 kW A2W COP and Heating Capacity

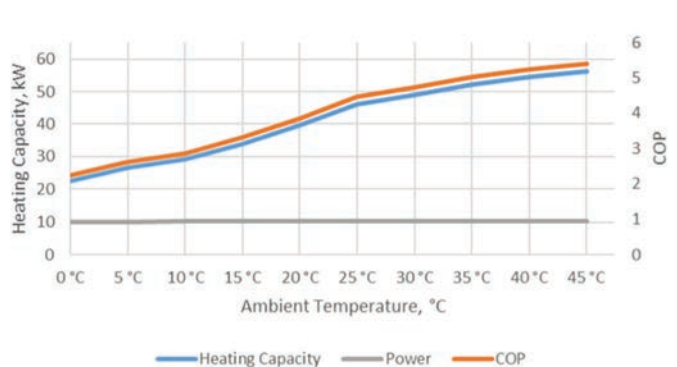

WATER TO WATER HEAT PUMP

FOR WHERE ENERGY EFFICIENCY IS ESSENTIAL



HEAT PUMP



WASTE HEAT RECOVERY



COMPACT



UP TO 7.0 COP EFFICIENCY

The Rheem Water to Water (W2W) range.

Includes units using readily available R134a for hot water heating up to 65°C, with a minimum entering water temperature on the building chiller loop of 12°C, or higher temperatures on the condenser loop, with the units being compact and suitable for indoor or outdoor installation.

EFFICIENCY

The ability of these units to provide a dual efficiency sees combined COPs of up to 7.0¹. The efficiency in hot water production is up to 4.0¹ and this leads to substantial savings in energy use and heating cost. The savings are magnified where the cooling by-product lessens a building's chilling load. COP in cooling are up to 3.0¹.

RETURN ON INVESTMENT

High COP of this product provides enormous savings compared to gas and electric heating systems which results in a very favourable return on investment making the W2W HP both a sound environmental and financial investment.

MORE KEY FEATURES

- Water Mark certified 316L stainless steel, double-wall brazed plate heat exchanger on domestic hot water side
- Multiple safeties including low temperature freeze protection and flow switch on the chilled water side
- Full commercial construction with marine grade aluminium case
- Rheem iQ control provides on board diagnostics, system configuration and optional high level BMS connectivity via Modbus or BACnet



Typical installation

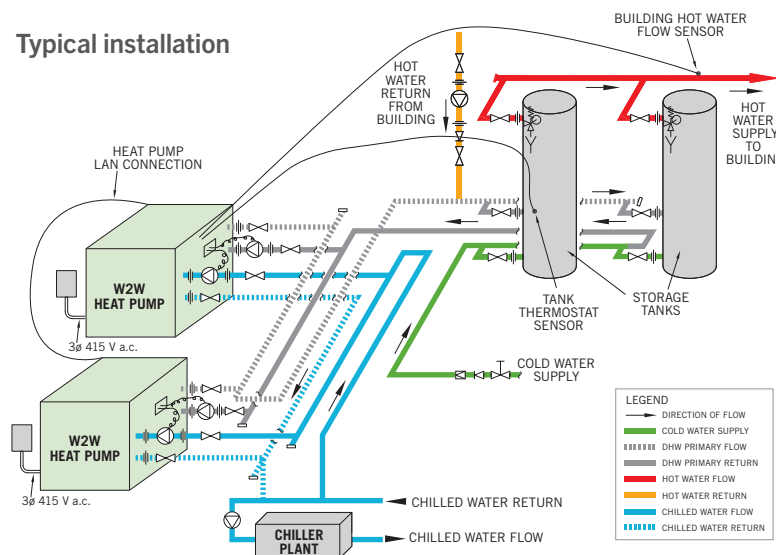

*Conditions Apply: For full terms and conditions please contact Rheem or visit www.rheem.com.au/rheem/help/Warranties

TECHNICAL DATA

15kW Model

95401500 - non-stackable 9540150S - stackable

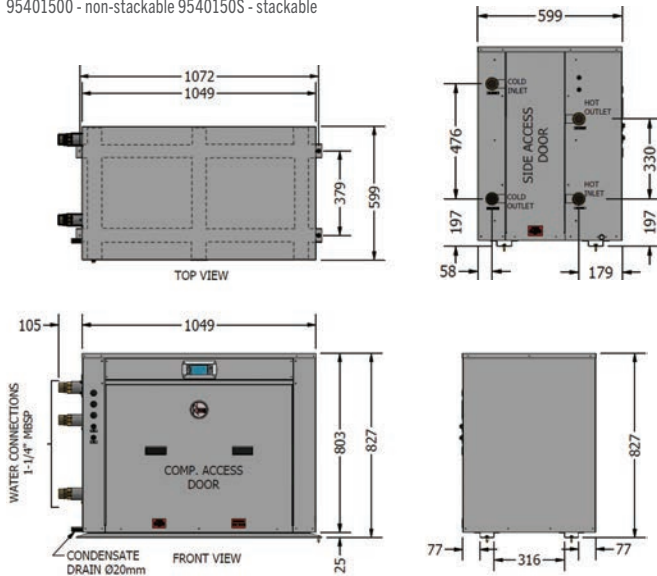

35kW Model

95403500 - non-stackable 9540350S - stackable

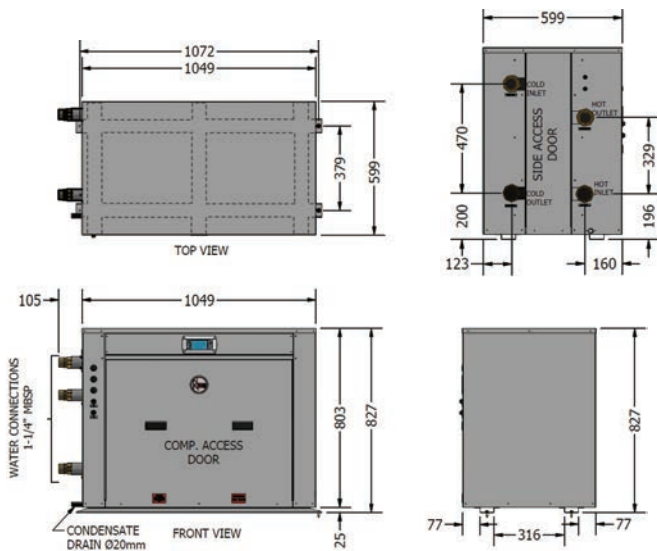

MODEL	15kW	35kW
Nominal Heating Capacity at 12°C Cold Water Temperature ¹	15kW	34.75kW
Nominal Cooling Capacity at 12°C Cold Water Temperature ¹	11.3kW	25.9kW
Nominal Heating Capacity at 35°C Cold Water Temperature ²	27.65kW	64.84kW
Power Input kW ¹	3.69kW	8.75kW
Coefficient of Performance (Heating) ¹ at 12°C	4.06	3.97
Coefficient of Performance (Cooling) ¹ at 12°C	3	3
Coefficient of Performance (Heating) ² at 35°C	6.97	7.1
Maximum DHW Temperature	65°C	
Refrigerant	R134a	
Hot Water Side		
TPR Valve Setting (VE/SS)	1000/850 kPa	
ECV Setting (VE/SS) ³	850/700 kPa	
Maximum Water Supply Pressure	800/680 kPa	
– Without ECV (VE/SS) ³	680/550 kPa	
– With ECV (VE/SS) ³		
Hot Water Side Flow Rate	1.1L/s	2.2L/s
Heat Exchanger Heating Design	316L Stainless steel – Double wall brazed plate	
Design Heating Temperature Difference	6°K	
Design Pressure Drop	40kPa	
Cold Water Side		
Maximum Water Supply Pressure	2450kPa	
Cold Water Side Flow Rate	1.1L/s	1.85L/s
Heat Exchanger Cooling Design	316L Stainless steel – Single wall brazed plate	
Design Cooling Temperature Difference	5°K	
Design Pressure Drop	40kPa	
Electrical Connection	3 Phase / 415V / 50Hz	
Max Current per Phase (running, incl pumps)	13.96	29.94
Minimum Circuit Size (per phase)	20A	40A
Sound Pressure Level	56dBa @ 3m	
Approx Weight Empty	100kg	120kg
Approx Weight Full	105kg	125kg
Storage per Heat Pump	400L to 4000L	400L to 8000L
Clearances		
Front	850mm	
Back	Nil mm	
Water Connections Side	500mm	
RHS Side	Nil mm	
Top (clearance above unit required for service personnel to stand)	350mm	

¹ Rating Conditions: Heating 39°C water in, 45°C water out, 51°C SCT, Cold 12°C water in, 7°C water outlet, 2°C SST.
² Rating Conditions: Heating 39°C water in, 45°C water out, 51°C SCT, Cold 35°C water in, 29.5°C water outlet, 10°C SST.
³ ECV not supplied with water heater

ACCESSORIES			
Storage Tank	Pump	BMS Card	LAN Cable
410L (VE)	2 x CM 3-2 (16kW)	17520-BACnet TCP/IP	17534
1000L to 5000L (SS)	2 x CM 10-1 (35kW)	17521-BACnet MS/TP 17522-Modbus RS485	

TECHNICAL DATA

PUMP AND PIPE SIZING CHART									
No. of Heat Pumps in Parallel	15kW				35kW				
	HOT SIDE				HOT SIDE				
	1	2	3	4	1	2	3	4	
Pump	Grundfos CM 3-2				Grundfos CM10-1				
Branch Size (mm)	40				50				
Header Size (mm)	40	50	65	80	50	80	100	100	
No. of Heat Pumps in Parallel	COLD SIDE				COLD SIDE				
	1	2	3	4	1	2	3	4	
Pump	Grundfos CM 3-2				Grundfos CM10-1				
Branch Size (mm)	40				50				
Header Size (mm)	40	50	65	80	50	80	100	100	

RECOVERY – 15 KW W2W								
Ambient Temperature °C	12	14	16	18	20	25	30	35
Output (kW)	14.99	16.46	16.97	18.06	19.21	22.39	26.04	27.65
Recovery – Litres per hour								
20°C rise	645	708	730	777	826	963	1120	1189
25°C rise	516	566	584	621	661	770	896	951
30°C rise	430	472	486	518	551	642	746	793
35°C rise	368	404	417	444	472	550	640	679
40°C rise	322	354	365	388	413	481	560	594
45°C rise	286	315	324	345	367	428	498	528
50°C rise	258	283	292	311	330	385	448	476
55°C rise	234	257	265	282	300	350	407	432

RECOVERY – 35 KW W2W								
Ambient Temperature °C	12	14	16	18	20	25	30	35
Output (kW)	34.75	38.21	39.44	42.00	44.72	52.25	60.98	64.84
Recovery – Litres per hour								
20°C rise	1494	1643	1696	1806	1923	2247	2622	2788
25°C rise	1195	1314	1357	1445	1538	1797	2098	2231
30°C rise	996	1095	1131	1204	1282	1498	1748	1859
35°C rise	854	939	969	1032	1099	1284	1498	1593
40°C rise	747	822	848	903	961	1123	1311	1394
45°C rise	664	730	754	803	855	999	1165	1239
50°C rise	598	657	678	722	769	899	1049	1115
55°C rise	543	597	617	657	699	817	954	1014

15 kW W2W COP and Heating Capacity

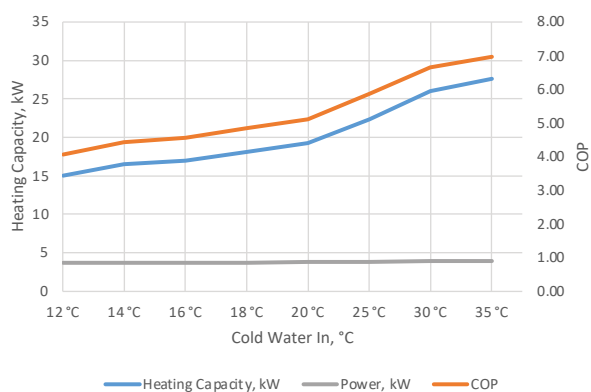

35 kW W2W COP and Heating Capacity

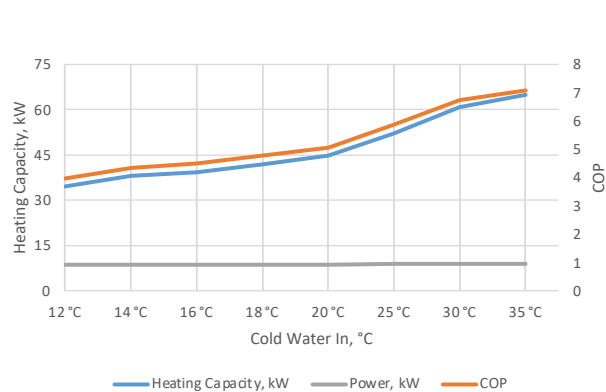

HEAT EXCHANGER TECHNOLOGY

The versatile, instant hot water, high pressure, hydraulic separator.

CASE STUDY

AIR APARTMENTS EASTWOOD, SA

Challenge

Air Apartments on Greenhill Road is one of Adelaide's premium residential apartment towers. Facilities include a gymnasium, 25m lap pool, spa and sauna, and family entertainment area.

The client wished to utilise the existing Raypak mechanical plant to provide domestic hot water from the basement

with pressure requirements exceeding those of storage tanks.

A pair of Rheem Crossflow hot water delivery systems were manifolded with RT storage tanks providing segregation between domestic hot water and the mechanical heating system, high pressure zones capability, accurate temperature control, and connectivity to the building management system.

Hot Water Solution

Total hot water plant installed across the precinct included:

- 2 x Rheem Crossflow systems manifolded
- 3 x Rheem RT1000 stainless steel storage tanks



RHEEM CROSSFLOW®

SUITED TO COMMERCIAL APPLICATIONS, PARTICULARLY MULTI-STOREY CONSTRUCTION

				
HIGH PRESSURE	CERTIFIED	BMS CONNECTIVITY	WASTE HEAT RECOVERY	SMALL FOOTPRINT

ROOFTOP PENTHOUSE VS. ROOFTOP PLANT

High working pressure of 1400kPa, the result of its hydraulic separator design, means Crossflow can be located in the basement of tall buildings - leaving rooftop space available for more profitable allocation.

MORE POWER FOR THE SPACE

Variable speed pumps accurately match the required energy load to deliver tankless, on-demand hot water with exceptional temperature control.

Crossflow uses 25% of the space of an equivalent storage-based system.

LOW PRESSURE LOSS

Crossflow exhibits exceptionally low pressure drop, so there's minimal impact on building design.

BUILT-IN REDUNDANCY

Designed with dual-head pump and twin heat exchangers that share the load, allowing isolation for maintenance, with no interruption to supply.

HIGHLY EFFICIENT HEAT EXCHANGE

Can be used with all heating types, solar, heat pump, gas, electric - as well as waste heat.

BMS AND SCADA CAPABILITY

Pump offers data transfer and monitoring capabilities to BMS or SCADA systems by an add-on CIM module suitable for Modbus, Bacnet and Lonworks.

MORE KEY FEATURES

- Factory assembled and tested on a hot dip galvanized frame
- All fittings and pipe work are 316L stainless steel
- Can be used as a hydraulic separator for solar, Co-gen and PP-R systems
- Grundfos Go remote APP Bluetooth enabled

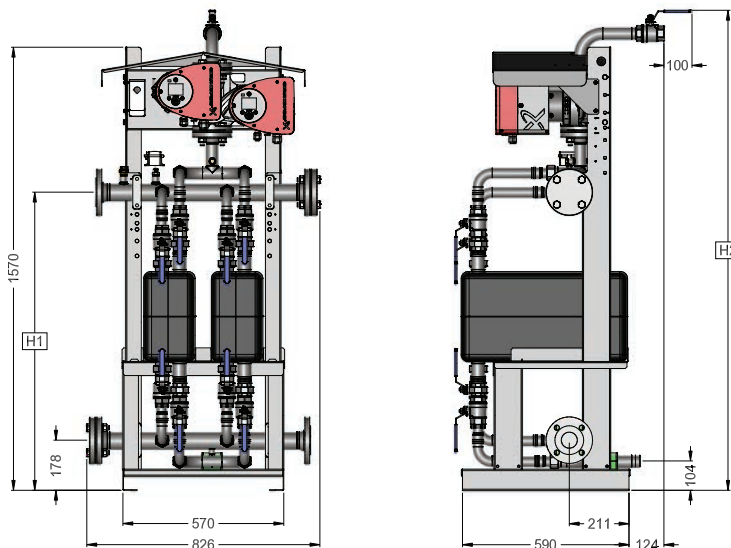

*Conditions Apply: For full terms and conditions please contact Rheem or visit www.rheem.com.au/rheem/help/Warranties

MODEL	DIM 'H1'	DIM 'H2'
RD200D701	877	1522
RD400D701	930	1575
RD600D701	993	1638
RD800D701	1056	1701

TECHNICAL DATA

DIMENSIONS AND TECHNICAL DATA TABLE - RHEEM CROSSFLOW							
Model			RD200	RD400	RD600	RD800	
Nominal Capacity		kW	200	400	600	800	
	Primary Side (non-potable)						
	Inlet Temp	°C	80	80	80	80	
	Flow Rate	L/min	48	114	144	186	
	Pressure Drop	kPa	24	47	36	36	
	Secondary Side (potable)						
	Inlet/Outlet Temp	°C	15/65	15/65	15/65	15/65	
	Flow Rate	L/min	57	115	172	223	
Parameters for Nominal Capacity Rating	Pressure Drop	kPa	37	47	51	48	
	Dimensions		H x W x D	mm			1364 x 761 x 700
	Weight		kg	130	138	147	156
Pipe Connections Primary Circuit	BSPF		RP1½				
Pipe Connections Secondary Circuit	50mm Flange Type E						
Max Operating Pressure Primary Circuit	kPa		1400 ²³				
Max Operating Pressure Secondary Circuit	kPa		1400 ²³				
Electrical Supply	230-240V 50/60Hz Hard Wired By Electrician						
Min Circuit Size	Amps		10				

²³ The maximum working pressure of each side of the system will be governed by the lowest operating appliance connected to it. The potable side (secondary side) water pressure must be higher than the non potable side (primary side) pressure.

Cross Flow Delivery Skid Secondary Side Flow Rate for Varying Primary Supply Temperatures and Secondary Side Temperature Rise

200kW						
Primary Temp	90	85	80	75	70	65
Output (kW)	270	215	200	190	160	100
Temp Rise	Secondary Side Flow Rate (L/min)					
65	60	47	44	42	35	
60	65	51	48	45	38	24
55	70	56	52	50	42	26
50	77	62	57	54	46	29
45	86	68	64	61	51	32
40	97	77	72	68	57	36
35	111	88	82	78	66	41

600kW						
Primary Temp	90	85	80	75	70	65
Output (kW)	740	680	600	535	450	300
Temp Rise	Secondary Side Flow Rate (L/min)					
65	163	150	132	118	99	
60	177	162	143	128	108	72
55	193	177	156	139	117	78
50	212	195	172	153	129	86
45	236	217	191	170	143	96
40	265	244	215	192	161	108
35	303	278	246	219	184	123

800kW						
Primary Temp	90	85	80	75	70	65
Output (kW)	940	870	800	695	580	400
Temp Rise	Secondary Side Flow Rate (L/min)					
65	207	192	176	153	128	
60	225	208	191	166	139	96
55	245	227	208	181	151	104
50	269	249	229	199	166	115
45	299	277	255	221	185	127
40	337	312	287	249	208	143
35	385	356	328	285	238	164

400kW						
Primary Temp	90	85	80	75	70	65
Output (kW)	500	450	400	365	300	200
Temp Rise	Secondary Side Flow Rate (L/min)					
65	110	99	88	80	66	
60	119	108	96	87	72	48
55	130	117	104	95	78	52
50	143	129	115	105	86	57
45	159	143	127	116	96	64
40	179	161	143	131	108	72
35	205	184	164	149	123	82

2 x 600kW						
Primary Temp	90	85	80	75	70	65
Output (kW)	1480	1360	1200	1070	900	600
Temp Rise	Secondary Side Flow Rate (L/min)					
65	326	300	265	236	198	
60	354	325	287	256	215	143
55	386	354	313	279	235	156
50	424	390	344	307	258	172
45	471	433	382	341	287	191
40	530	487	430	383	323	215
35	606	557	491	438	369	246

2 x 800kW						
Primary Temp	90	85	80	75	70	65
Output (kW)	1880	1740	1600	1390	1160	800
Temp Rise	Secondary Side Flow Rate (L/min)					
65	415	384	353	307	256	
60	449	416	382	332	277	191
55	490	453	417	362	302	208
50	539	499	459	398	333	229
45	599	554	510	443	369	255
40	674	624	573	498	416	287
35	770	713	655	569	475	328

TECHNICAL DATA

Rheem Crossflow Maximum Output (Tin¹⁵°C-Tin⁶⁵°C) vs. Primary supply temp

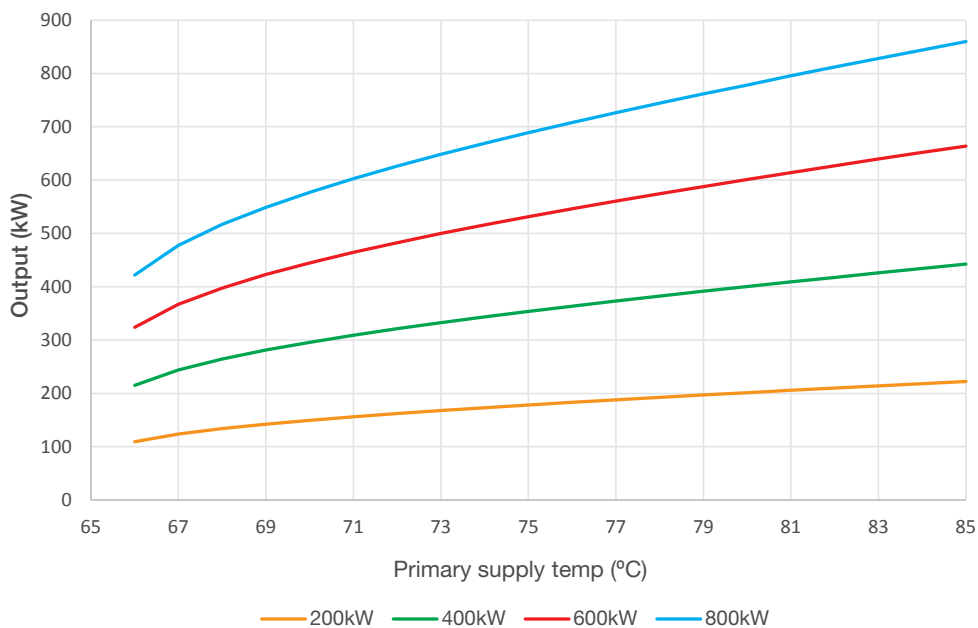

Rheem Crossflow Secondary Side Pressure Drop vs. Flow Rate

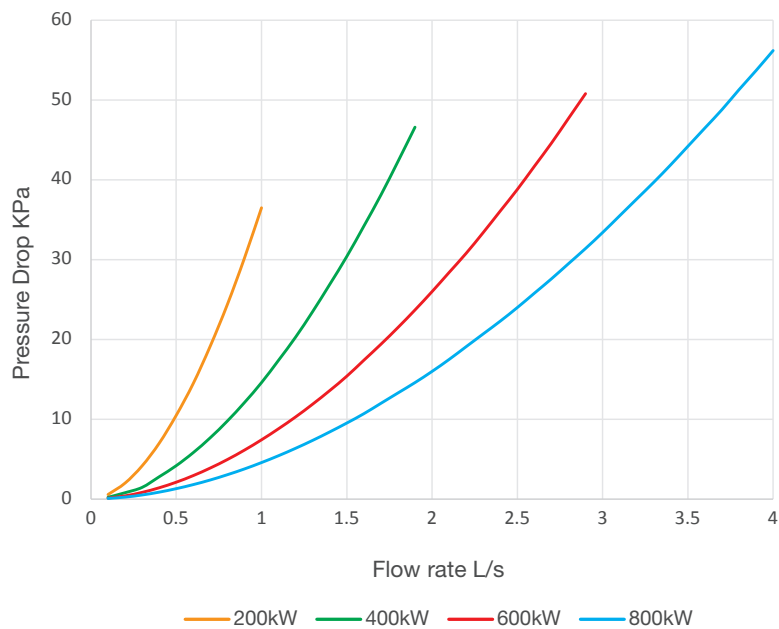

BRAZED PLATE HEAT EXCHANGER

SUITED TO CO-GEN AND TRI-GEN PLANTS, PROCESS HEATING, AND PRESSURE REDUCTION STATIONS



STAINLESS STEEL



EASY TO MAINTAIN



WASTE HEAT RECOVERY



MINIMUM PRESSURE DROP

The most versatile heat exchanger available.

IDEAL FOR CUSTOM ENGINEERING DESIGNS

316L stainless steel, single wall, brazed plate heat exchangers can be bolted together when more capacity is needed. Suits specialist applications, where high temperature and high pressure are needed.

EASY TO INSPECT AND MAINTAIN

Unlike other products that use internal coils, the external heat exchanger is easily isolated for repairs and maintenance.

MINIMAL PRESSURE LOSS ENERGY TRANSFER

Parallel brazed plate construction means increased flow without the pressure drop and high heat transfer efficiency in a compact package.

Contact Rheem for assistance confirming the rated capacity of heat exchangers taking into consideration site specific requirements.

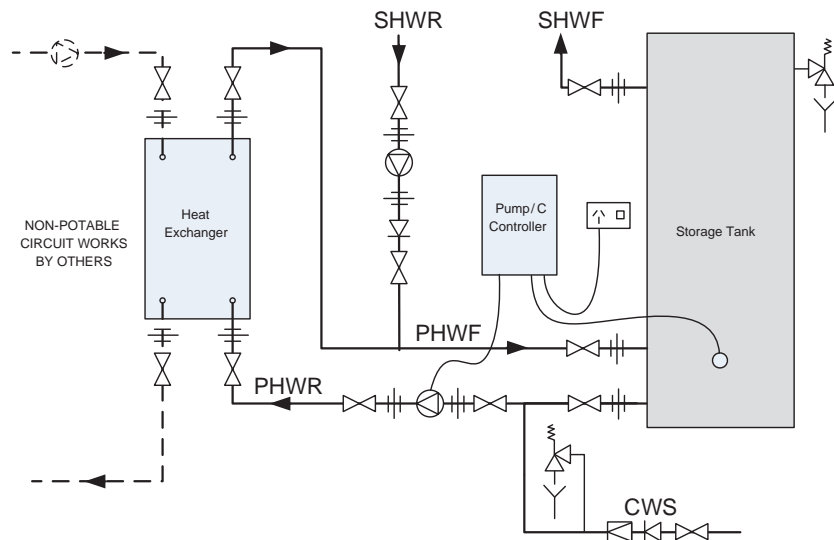
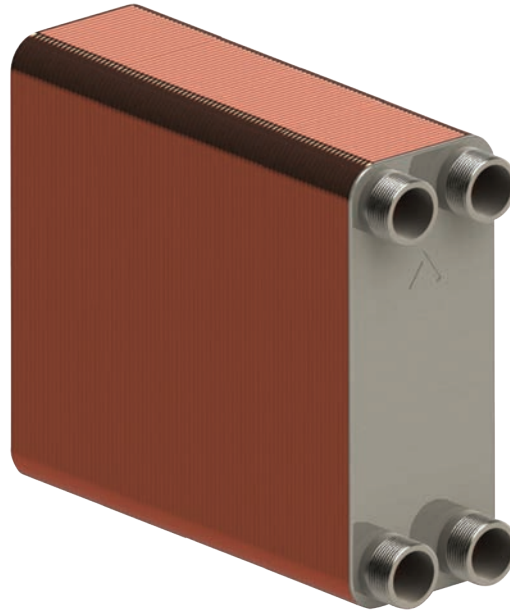

*Conditions Apply: For full terms and conditions please contact Rheem or visit www.rheem.com.au/rheem/help/Warranties

Legend

CWS: cold water supply
 PHWR: primary hot water return
 PHWF: primary hot water flow
 SHWS: secondary hot water supply
 SHWR: secondary hot water return

-  ECV
-  TPR valve
-  Tundish
-  Isolation valve
-  Non return valve
-  Pressure limiting valve
-  Union
-  Circulator or pump

TECHNICAL DATA

DIMENSIONS AND TECHNICAL DATA TABLE - RHEEM HEAT EXCHANGER									
Part Number				0191750	0191751	0191752	0191753	0191754	
Nominal Rating				kW	50	100	150	200	250
Parameters for Nominal Rating	Non Potable Side	Inlet/Outlet Temp	°C	80/60	80/60	80/60	80/60	80/60	
		Flow Rate	L/sec	0.61	1.22	1.83	2.44	3.05	
		Pressure Drop	kPa	2.65	3.74	5.00	6.98	9.83	
	Potable Side	Inlet/Outlet Temp	°C	45/65	45/65	45/65	45/65	45/65	
		Flow Rate	L/sec	0.61	1.21	1.82	2.43	3.03	
		Pressure Drop	kPa	2.39	3.59	4.91	6.91	9.79	
Dimensions		Depth (D)	mm	104	160	221	277	333	
Weight			kg	6	9	12	15	18	
Operating Pressure			kPa	3000 ¹					
Electrical Supply (Temperature Controller)				230-240V 50/60Hz Hard wired by Electrician					

¹ The maximum working pressure of each side of the system will be governed by the lowest operating appliance connected to it. The potable side (secondary side) water pressure must be higher than the non potable side (primary side) pressure.

POTABLE SIDE PUMP AND PIPE SIZING					
Heat Exchanger Model	Qty In Parallel	Output (kW)	Design Flow Rate	Minimum Potable Primary F & R Pipe Size (mm)	Pump Model / Speed Setting
0191750	1	50	0.61	32	UPS20-60N / 3
0191750	2	100	1.22	40	UPS32-80N / 3
0191751	1	100	1.21	40	UPS32-80N / 3
0191751	2	200	2.42	50	UPS40-60/2FB / 2
0191752	1	150	1.82	50	UPS32-80N / 3
0191752	2	300	3.64	65	UPS40-60/2FB / 3
0191753	1	200	2.43	50	UPS40-60/2FB / 3
0191753	2	400	4.86	80	UPS50-120FB / 1
0191754	1	250	3.03	65	UPS40-60/2FB / 3
0191754	2	500	6.06	80	UPS50-120FB / 3

NOTE: Pipe sizing, pump selection and installation of the NON-POTABLE circuit is not covered by Rheem. Pipe and pump sizing is for potable water side only between the heat exchanger and storage tank/s and is based on 25m TOTAL pipe run and 20 x 90° bends @1.2m/s. If the piping is beyond this scope, please contact Rheem for assistance.

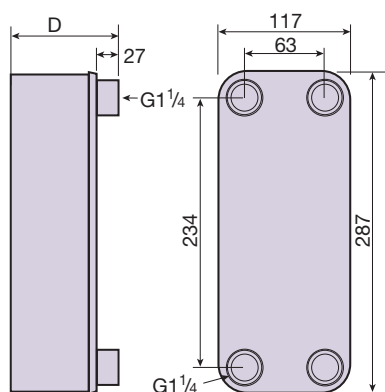

GUARDIAN WARM WATER

Maximum safety, protection and operating efficiency, in one centralised system.



CASE STUDY

**MODBURY HOSPITAL
ADELAIDE, SA**

Challenge

The upgrade of the existing hospital infrastructure was to provide specific plantroom solutions for requirements of 4 x operating theatres, general ward with 180 beds, commercial kitchen and laundry, central sterile services department (CSSD), emergency department and general amenities and café.

Hot Water Solution

Rheem Guardian is specifically used to deliver a temperature suitable for ablution areas, whilst the rest of the hot water system provides the Hospital for all other demands.

Total hot water plant installed across the precinct included:

- 2 x Rheem Tankpak systems model TPI05NFD
- 4 x Rheem RT1000 stainless steel storage tanks

- 4 x Rheem Guardian 240L warm water with UV disinfectant



GUARDIAN WARM WATER

**WHERE CONTROLLED
WARM WATER IS NEEDED**



**SUPERIOR
SAFETY**



**LOW OPERATING
COSTS**



**FAST
REPLACEMENT**



**SERVICED
WARM WATER**

HIGH SAFETY PERFORMANCE

Thermostatic mixing valve technology for accurate temperature control and ultraviolet disinfection with no impact on pipework or water quality. Guardian features a tamper-proof design and UV fault detection for protection ensuring consistent performance and safety.

LOWER OPERATING COSTS

Centralised temperature monitoring and valve maintenance means reduced capital and operating costs in facilities with more than 22 beds, compared with equivalent TMV systems.

FAST REPLACEMENT

With more Rheem Guardian units in Australia than any other centralised system, they're easy to replace in existing installations. Plus when regulations make tempering mandatory when replacing a water heater, Guardian can be added without individually tempering a whole building.

MULTIPLE INSTALLATION AND DESIGN OPTIONS

Available in three sizes, easily manifolded for increased capacity and able to be installed both inside and outside¹. Plus the primary heating plant can also be used to supply both tempered and non-tempered water.

SERVICED BY RHEEM

Rheem offers a national Guardian commissioning, service and maintenance program for peace of mind.



*2 year commercial cartridge warranty.
*Conditions Apply: For full terms and conditions please contact Rheem or visit www.rheem.com.au/rheem/help/Warranties



Typical Installation Rheem Warm and Hot Water

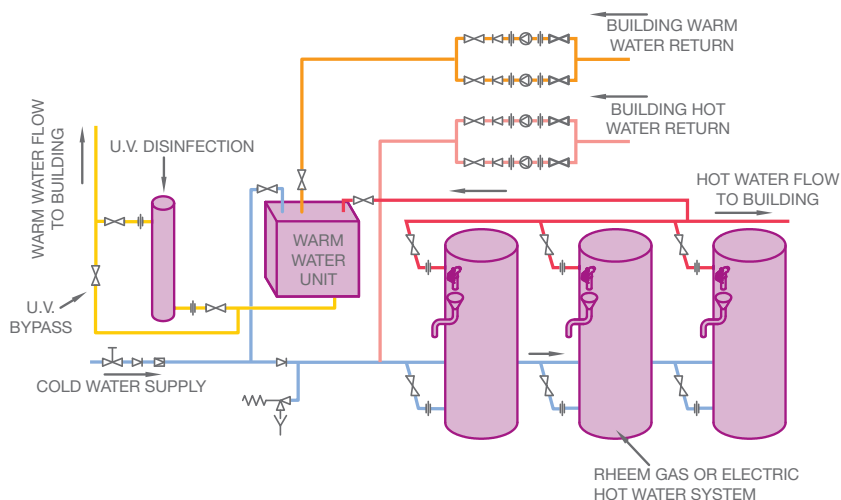

TECHNICAL DATA

WARM WATER				
Model		940 080	940 160	940 240
Nominated Flow Rate ²	L/min	80	160	240
Max. Water Supply Pressure – Static/Dynamic	kPa	1000/800	1000/800	1000/800
Min. Water Supply Pressure	kPa	500	500	500
Thermostatic Control Range	°C	25 – 60	25 – 60	25 – 60
Max. Outlet Temperature (Sanitising) ³	°C	70	70	70
Min. Temp Differential Between				
Cold Supply and Outlet (Flow Conditions)	°C	15	15	15
Hot Supply and Outlet (Flow Conditions)	°C	15	15	15
Recommended Minimum Recirculation Flow Rate ²	L/min	8	16	24
Recommended Minimum Temperature Loss in Recirculation Circuit	°C	2	2	2
Weight – Empty	kg	38	56	73
Indoor/Outdoor		yes	yes	yes
ULTRA VIOLET DISINFECTION				
Model		940 001	940 002	940 002
Nominated Maximum Flow Rate	L/min	83	250	250
Weight – Empty	kg	15	15	15
Electrical rating 240v 50Hz	Watts Amps	216 0.9	480 2.0	480 2.0
Viewing Window		yes	yes	yes
Audible Lamp Fail Alarm		yes	yes	yes
Volt Free Contacts for Remote Alarm		yes	yes	yes
Hours Run Meter		yes	yes	yes
Indoor/Outdoor ¹		yes	yes	yes

¹ UV chamber must be installed under cover when installed outdoor.
² At mid blend and equal dynamic supply pressures.
³ It is recommended the ultra violet disinfection system lamps be de-energised if the outlet temperature exceeds 50°C.

Warm Water Roughing in dimensions

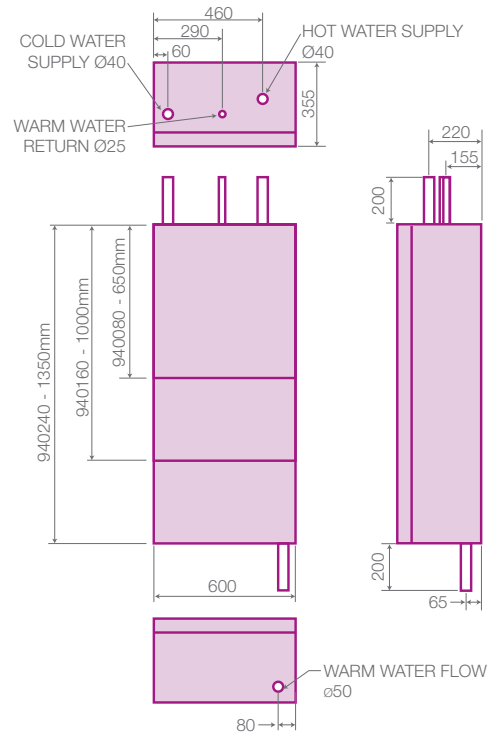

940 001 UV Disinfection Roughing in dimensions

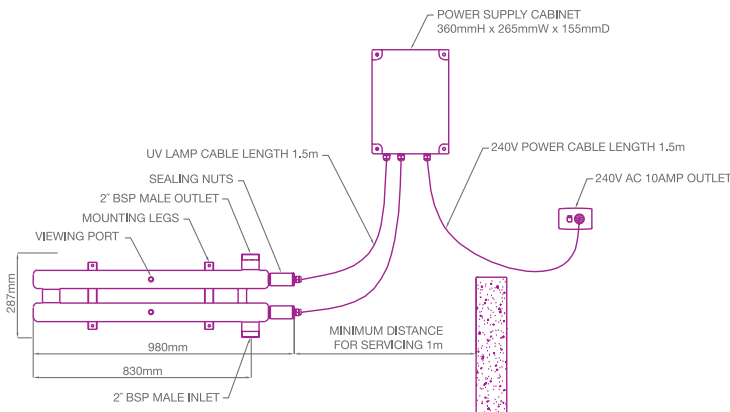

940 002 UV Disinfection Roughing in dimensions

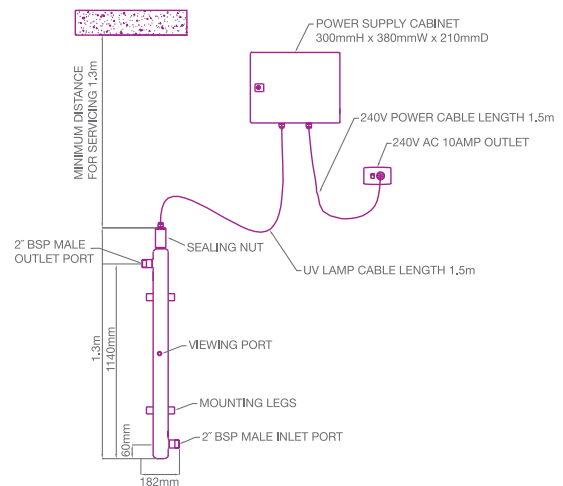

STORAGE TANKS

Market-leading storage tanks from small to large.



CASE STUDY

**AUSTRALIAN NATIONAL UNIVERSITY
CANBERRA, ACT**

Challenge

Union Court Canberra is a new environmentally sustainable student accommodation precinct for 450 students.

Rheem Commercial Air to Water Heat Pumps helped solve the spatial issues by allowing double stacking of 8 x 16 kW horizontal discharge units for the main plant.

Hot Water Solution

The bottom flange of RT Stainless Steel storage tanks were fitted with auxiliary

electric Heating Units providing back-up during low atmospheric temperature intervals. A "soft start" electrical set-up was employed to stage the auxiliary heating units to eliminate sudden electrical load.

Across the entire precinct, Rheem supplied:

- 11 x Rheem 16kW Air to Water (A2W) Commercial Heat Pumps
- 6 x Rheem 2000L RT-Series Storage Tanks with in-tank 30 kW Heating Unit bundles
- 4 x Rheem 1000L RT-Series Storage Tanks with in-tank 15 kW Heating Unit bundles



RHEEM 610 SERIES

SUITED TO INTEGRATION WITH ALMOST ANY SYSTEM



STORAGE



LARGER ANODE



HIGH FLOW CONNECTION



NO PRESSURE DROP

The work-horse storage system that keeps on working, in a wider range of water quality environments.

FLEXIBLE

Compatible with CFWH, Raypak, solar preheat and heat pump storage or as additional storage for a Rheem gas or electric hot water system.

HIGHLY DURABLE IN POOR WATER QUALITY AREAS

Manufactured with commercial grade vitreous enamel and larger anode.

STABLE PRESSURE

No coils means there's virtually no pressure drop.

MORE KEY FEATURES

- Suitable for up to 82°C for sanitising applications
- Range of sizes
- 50mm high flow water connections
- Ease of fitment and replacement



*Conditions Apply: For full terms and conditions please contact Rheem or visit www.rheem.com.au/rheem/help/Warranties

TECHNICAL DATA

DIMENSIONS AND TECHNICAL DATA TABLE				
Model number			610 340	610 430
			Vitreous Enamel	
Storage capacity		Litres	325	410
Dimensions	A	mm	1640	1840
	B	mm	640	685
	C	mm	640	685
	D	mm	1008	1210
	E	mm	115	108
	L	°	90°	84°
	M	°	32°	30°
	N	mm	290	273
Weight Empty		kg	96	117
Inlet/Outlet Connections (BSPF)			RP2	RP2
T&PR Valve Connection (BSPF)			RP $\frac{3}{4}$	RP $\frac{3}{4}$
Remote Thermostat Connection (1 x thermowell supplied)			RP $\frac{1}{2}$	RP $\frac{1}{2}$
T&PR Valve Setting		kPa	1000	1000
Expansion Control Valve (ECV) ¹ Setting		kPa	850	850
Maximum Water Supply Pressure				
without ECV ¹ fitted		kPa	800	800
with ECV ¹ fitted		kPa	680	680
Maximum Stored Water Temperature		°C	82	82
Manifold – Min. Centre to Centre		mm	890	935
Maintenance Rate		kWH/day	3.1	4.3

¹ Expansion control valve not supplied with the water heater.

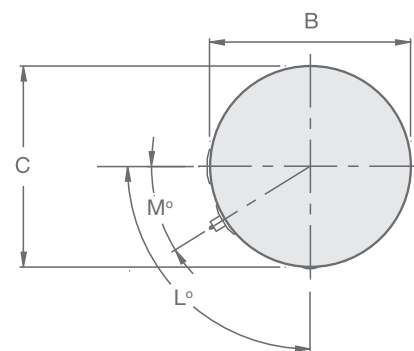
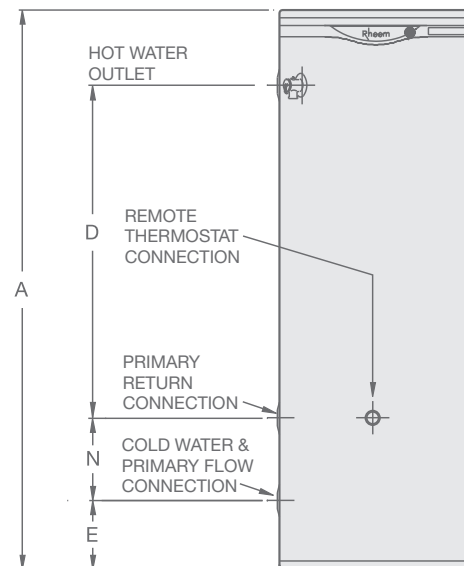

RHEEM RT SERIES

SUITED TO LARGE COMMERCIAL APPLICATIONS



STORAGE



EASY TO INSTALL



HIGH PRESSURE



UP TO 5,000L CAPACITY



SUPERIOR INSULATION

The high pressure, high capacity storage tank.

HIGH PRESSURE

Carbon steel tanks suit 500kPa operation and stainless steel tanks suit up to 850kPa operation. That's up to 20% more operating pressure than competitor tanks of an equivalent size.

HIGH CAPACITY

Available in nominal 1000, 2000, 3000, 4000, 5000L capacities. Multiple tanks of the same capacity can be manifolded in parallel to store larger volumes for reduced footprint and installation flexibility.

EASY TO INSTALL

The only large capacity tank to fit through a single door, the RT1000 tank is just 800mm and can be easily installed in replacement situations. Models up to RT4000 tank fits easily through a double 1400mm door.

HIGH PERFORMANCE INSULATION

100mm polypropylene insulation, with a bonded aluminium cladding suitable for outdoor installation. Polypropylene insulation is fireproof, resistant and resistant to rot, moisture, mould, bacteria and rodents, hypoallergenic, 100% recyclable, light weight and self-supporting.

WITHSTANDS HIGH TEMPERATURES

Can store water up to 90°C.

MORE KEY FEATURES

- Available in a fully welded carbon steel cylinder for indirect applications, or 316L stainless steel for direct water applications
- Flange plates and a variety of high flow 50mm water fittings allow for different auxiliary options such as heat exchange coils (not supplied), electric heating unit bundles, heat pumps, gas water heaters, solar or waste heat
- 4 x sensor well ports provided to suit installation
- 1 x sensor well supplied
- Additional sensor wells may be required, application dependent



ACCESSORY

Additional Temperature Sensor Well

079438



*Conditions Apply: For full terms and conditions please contact Rheem or visit www.rheem.com.au/rheem/help/Warranties

TECHNICAL DATA

DIMENSIONS AND TECHNICAL DATA TABLE						
Model number		RT1000	RT2000	RT3000	RT4000	RT5000
		Stainless steel / Carbon steel				
Storage capacity	Litres	920	2055	2960	3820	5180
Dimensions	A mm	2200	2565	2845	2918	3128
	B mm	1000	1300	1450	1600	1800
	C mm	800	1100	1250	1400	1600
	D mm	510	555	600	628	747
	E mm	1435	1735	1945	1963	2132
	F mm	417	462	505	533	667
	G mm	879	1024	1135	1163	1287
	H mm	1341	1586	1765	1793	1907
	J mm	1803	2148	2395	2423	2527
	P mm	685	988	1140	1290	1378
	Q mm	80	100	100	100	100
K °	50	50	50	50	50	
L °	35	35	35	35	35	
M °	75	75	75	75	75	
Weight Empty	kg	136/115	245/245	330/334	455/455	660/535
Inlet/Outlet Connections (BSPF)		RP2	RP2	RP2	RP2	RP2
T&PR Valve Outlet Connection (BSPF)		RP1¼	RP1¼	RP1¼	RP1¼	RP1¼
Vent Connection (BSPF)		RP1½	RP2	RP2	RP2	RP2
Drain Connection (BSPF)		RP1¼	RP1¼	RP1¼	RP1¼	RP1¼
Remote Thermostat Connection (1 x thermowell supplied)		RP½	RP½	RP½	RP½	RP½
T&PR Valve Setting (stainless steel/carbon steel)	kPa	850/500	850/500	850/500	850/500	850/500
Expansion Control Valve (ECV) ¹ Setting (stainless steel/carbon steel)	kPa	700/NA	700/NA	700/NA	700/NA	700/NA
Maximum Water Supply Pressure						
without ECV ¹ fitted (stainless steel/carbon steel)	kPa	680/400	680/400	680/400	680/400	680/400
with ECV ¹ fitted (stainless steel/carbon steel)	kPa	550/NA	550/NA	550/NA	550/NA	550/NA
Maximum Stored Water Temperature	°C	90	90	90	90	90
Manifold – Min. Centre to Centre (piping one side)	mm	1350	1550	1700	1850	2050
Manifold – Min. Centre to Centre (piping both sides)	mm	1500	1700	1850	2000	2200
Maintenance Rate	kWH/day	8.5	10.8	12.3	13.5	15.3

¹ Expansion control valve not supplied with the water heater.

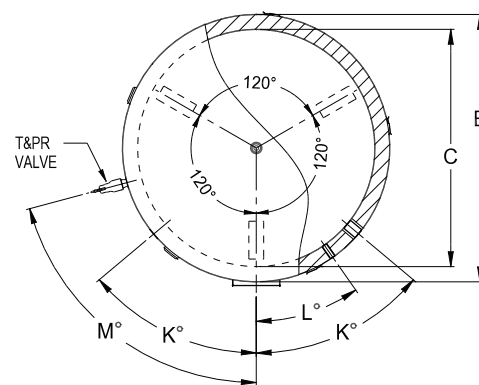
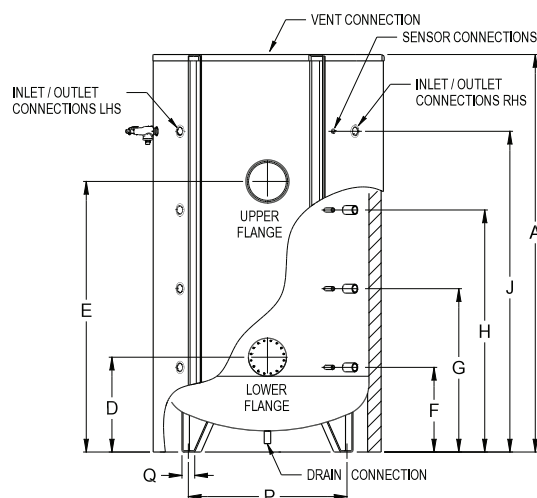

WATER CAPACITY ABOVE NOMINATED FITTING (Litres)						
Model number		RT1000	RT2000	RT3000	RT4000	RT5000
Storage Capacity (L)		920	2055	2960	3820	5180
Fitting	Dim J	116	235	309	438	695
Fitting	Dim H	345	763	1082	1408	1942
Fitting	Dim G	575	1292	1855	2377	3188
Fitting	Dim F	804	1820	2628	3347	4435
Upper Flange	Dim E	299	623	861	1146	1489
Lower Flange	Dim D	758	1732	2511	3201	4274

BOILING WATER

High-flow, low-fuss,
boiling water solutions.



BOILING WATER LAZER ECO

SUITED TO SMALL OFFICE
KITCHENS AND SITE SHEDS



ELECTRIC



ECONOMICAL



UP TO 50 CUPS¹
INSTANTLY



ECO MODE

High flow boiling water units for commercial applications.

SAFETY FIRST

Optional retrofit tap prevents accidental dispensing with its 3-step action.

LOW FUSS

Delivers up to 50 cups¹ instantly, with recovery of up to 123 cups¹ per hour; an in-built indicator shows red when heating and green when in energy conservation mode.

ENERGY MANAGEMENT OPTIONS

One-touch activation button for Eco Mode, automatically turns the Lazer Eco off after two hours with no use. Electronic temperature sensors allow staged filling, more reliable than cistern-valve models and boiling point is automatically calibrated to installation altitude.

MORE KEY FEATURES

- Available in 3, 5 and 7.5 litre
- White enamel



*Conditions Apply: For full terms and conditions please contact Rheem or visit www.rheem.com.au/rheem/help/Warranties

BOILING WATER LAZER COMMERCIAL

SUITED TO COMMERCIAL KITCHENS, SPORTING CLUBS AND LARGE WORKPLACES



ELECTRIC



FAST FILLING



UP TO 247 CUPS¹ INSTANTLY



ECO MODE



ROBUST CONSTRUCTION

The high-flow, high-capacity, boiling water unit.

HIGH FLOW

High flow tap saves time with up to 35% faster filling compared to other like-for-like units³.

HIGH CAPACITY

Fill pots as well as cups: delivers up to 247 cups¹ as fast as it can be drawn with a recovery of between 135 and 265 cups¹ per hour.

ENERGY MANAGEMENT OPTIONS

The user interface allows people to easily adjust temperatures. While a seven-day programmable timer, turns energy off when boiling water isn't needed.

Sleep mode turns off the system automatically when it hasn't been used for two hours. Electronic temperature sensors allow staged filling, more reliable than cistern-valve models and boiling point is automatically calibrated to installation altitude.

ROBUST MANUFACTURE

All ranges come with copper tanks, a high water supply pressure rating (1000kPa) and optional filter kit for water protection and improved water taste. There are also automatic safety devices to safeguard the unit against boiling dry.

MORE KEY FEATURES

- Available in 7.5, 10, 15, 25 and 40 litre
- White enamel or stainless outer jacket



*Conditions Apply: For full terms and conditions please contact Rheem or visit www.rheem.com.au/rheem/help/Warranties

BOILING WATER LAZER OFFICE

SUITED TO SMALL
OFFICE KITCHENS



ELECTRIC



SLEEP MODE



UP TO 35 CUPS¹
INSTANTLY



ECO MODE

The Rheem Lazer Office offers elegance with efficiency.

LAZER® OFFICE

- Available in 3 and 5 litre (20 and 35 cups¹)
- Recovery of up to 135 cups¹ per hour
- Available in easy clean white enamel

LOW ENERGY CONSUMPTION

- Seven day timer ensures efficiency when boiling water is not required by turning the energy off
- Sleep mode will turn off the system automatically when it has not been used for a set period of time

CONCEALED TAP

- Press the concealed tap for instant boiling water or pull the tap for hands free filling
- The user interface allows people to easily adjust temperatures



*Conditions Apply: For full terms and conditions please contact Rheem or visit www.rheem.com.au/rheem/help/Warranties

TECHNICAL DATA

LAZER BOILING WATER UNIT		LAZER ECO		
WHITE POWDER COAT		70303W-AU	70305W-AU	70307W-AU
Capacity	Litres	3	5	7.5
Delivery – Initial	Litres	3.5	6	8.5
	Cups ¹	21	35	50
Recovery	L/hr	17.5	23	23
	Cups/hr ¹	103	135	135
Approx Weight Empty	kg	6	8	9
Approx Weight Full	kg	10	15	19
Minimum Water Pressure	kPa	50	50	50
Maximum Water Pressure	kPa	1000	1000	1000
Input	kW	1.8	2.4	2.4
Electrical Connection		supplied with 10 Amp 3 pin plug and flex		
Plumbing Connections		½" BSPM		
Product Dimensions				
A width of unit	mm	283	336	336
B depth of unit excluding tap	mm	160	192	192
C height of unit	mm	435	465	515
D depth of unit including tap	mm	280	312	312

¹ Cup size is 170ml.

LAZER BOILING WATER UNIT		LAZER COMMERCIAL				
WHITE POWDER COAT		70207W-AU	70210W-AU	70215W-AU	70225W-AU	70240W-AU
STAINLESS STEEL		70207S-AU	70210S-AU	70215S-AU	70225S-AU	70240S-AU
Capacity	Litres	7.5	10	15	25	40
Delivery – Initial	Litres	8.5	11	17	27	42
	Cups ¹	50	65	100	159	247
Recovery	L/hr	23	23	23	35	45
	Cups/hr ¹	135	135	135	206	265
Approx Weight Empty	kg	9	10	15	17	19
Approx Weight Full	kg	19	22	34	47	67
Minimum Water Pressure	kPa	50	50	75	75	100
Maximum Water Pressure	kPa	1000	1000	1000	1000	1000
Input	kW	2.4	2.4	2.4	3.6	4.6
Electrical Connection		Supplied with 10 Amp 3 Pin Plug and Flex			Hard wired	
Plumbing Connections		½" BSPM				
Product Dimensions						
A width of unit	mm	336	336	336	336	490
B depth of unit excluding tap	mm	192	192	299	299	340
C height of unit	mm	515	615	515	720	615
D depth of unit including tap	mm	312	312	419	419	460

¹ Cup size is 170ml.

TECHNICAL DATA

LAZER BOILING WATER UNIT		LAZER OFFICE	
WHITE POWDER COAT		70103W-AU	70105W-AU
Capacity	Litres	3	5
Delivery – Initial	Litres	3.5	6
	Cups ¹	21	35
Recovery	L/hr	17.5	23
	Cups/hr ¹	103	135
Approx Weight Empty	kg	6	8
Approx Weight Full	kg	10	15
Minimum Water Pressure	kPa	50	50
Maximum Water Pressure	kPa	1000	1000
Input	kW	1.8	2.4
Electrical Connection	Supplied with 10 Amp 3 Pin Plug and Flex		
Plumbing Connections	½" BSPM		
Product Dimensions			
A width of unit	mm	285	334
B depth of unit	mm	209 ²	241 ²
C height of unit	mm	435	465

¹ Cup size is 170ml.

² Includes 25mm depth for supplied backing plate.

Lazer Eco (703 Series)

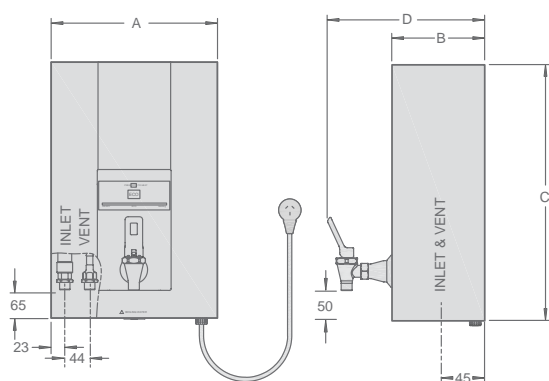

Lazer Commercial (702 Series)

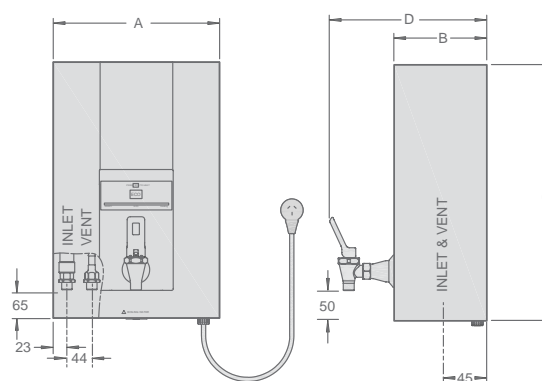

Lazer Office (701 Series)

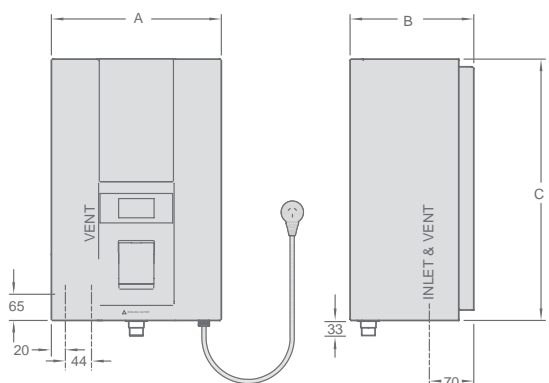

WALL MOUNTED – BOILING WATER APPLIANCES



Lazer® Commercial – 7.5L

70207W-AU – White

70207S-AU – Stainless Steel

Max 185 cups p/hr²
Up to 50 people

Lazer® Commercial – 10L

70210W-AU – White

70210S-AU – Stainless Steel

Max 199 cups p/hr²
Up to 65 people

Lazer® Commercial – 15L

70215W-AU – White

70215S-AU – Stainless Steel

Max 235 cups p/hr²
Up to 90 people

Lazer® Commercial – 25L

70225W-AU – White

70225S-AU – Stainless Steel

Max 365 cups p/hr²
Up to 150 people

Lazer® Commercial – 40L

70240W-AU – White

70240S-AU – Stainless Steel

Max 512 cups p/hr²
Up to 250 people



Lazer® Eco – 3L

70303W-AU – White

Max 124 cups p/hr²
Up to 20 people

Lazer® Eco – 5L

70305W-AU – White

Max 170 cups p/hr²
Up to 35 people

Lazer® Eco – 7.5L

70307W-AU – White

Max 185 cups p/hr²
Up to 50 people



Lazer® Office – 3L

70103W-AU – White

Max 124 cups p/hr²
Up to 20 people

Lazer® Office – 5L

70105W-AU – White

Max 170 cups p/hr²
Up to 35 people

Boiling water extras

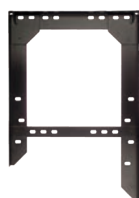

Retrofit Mounting Bracket

318961 - 3L Lazer® Eco

318962 - 5L Lazer® Eco



317327

5 micron remote filter kit for Rheem Lazer® products

Increase Productivity

Gain cost advantages by replacing the staff room jug or kettle with a Rheem Boiling Water appliance. If you have over 20 staff and each person drinks 3 cups of tea or coffee a day, think of the time saved and increased productivity.



Safety Tap

319068 – Lazer® Commercial



Safety Tap

319069 – Lazer® Eco

² Total of initial delivery and recovery per/hr (cup size 170ml).

³ Based on Rheem flow rate of up to 11 litres/min versus a competitor flow rate of up to 8 litres/min.

COMMERCIAL SOLAR

A range of market-leading technologies ideal for large-scale solar thermal systems or integration into existing systems.

CASE STUDY

KATHERINE DISTRICT HOSPITAL KATHERINE, NT

Challenge

Katherine District Hospital is a critical piece of public healthcare infrastructure catering to patients from some of the most remote communities in the Northern Territory, servicing an area of 336,674 km². The hospital needed a major hot water system upgrade, converting from an old heat exchange system to an electric-boosted solar pre-heat system.

Hot Water Solution

Rheem provided a renewable energy solution comprised of 24 x Solar Collectors and 3 x RT1000 Stainless Steel Commercial Storage tanks to store the high percentage of solar contribution. The new system services 11 bedrooms, 2 delivery-birth suites, 2 theatres and 3 utility rooms. The tanks were craned to the rooftop, and the pipe work was manifolded to allow ease of tank replacement at end-of-life.



LOLINE DIRECT SOLAR

SUITED TO MOST COMMERCIAL AND INDUSTRIAL APPLICATIONS



SOLAR



FAST INSTALLATION



OVERHEATING PROTECTION



HIGH FLOW FITTINGS



BMS CAPABLE

The most efficient direct solar system to use and install.

HIGHLY EFFICIENT

Unlike evacuation tube technology, Loline has no progressive efficiency loss, providing prolonged energy savings, making it a more efficient direct solar option at typical hot water temperatures.

SAVE TIME ON SITE

Utilising the collector's internal header along with a unique expansion tube, Loline allows up to 24 collectors in a row to be quickly and easily connected.

MULTIPLE INSTALLATION OPTIONS

A range of tank capacities and any number of solar collectors can be arranged in a variety of combinations with tanks mounted at the same level or below the collectors to suit site requirements.

AUTOMATIC OVERHEATING PROTECTION

During low-use periods, small amounts of hot water are automatically transferred to storage tanks to prevent collectors overheating and an optional 3-way valve can divert this excess energy to the building recirculation circuit, further reducing operating costs.

PARTIAL FROST PROTECTION

Warranted against freeze damage in areas below 400m altitude, and an optional electric or gas water heater can be incorporated in the design to assist freeze protection.



MULTIPLE BOOST OPTIONS

Boost options include heat pump, gas, or electric, and large tanks can be boosted at the top of the solar tank minimising footprint.

MORE KEY FEATURES

- Eligible for STCs (tank dependent)
- Select from 325 litre and 410 litre vitreous enamel storage tanks or RT1000 to 5000 stainless steel storage tanks



*Conditions Apply: For full terms and conditions please contact Rheem or visit www.rheem.com.au/rheem/help/Warranties

SOLAR RADIATION DATA										
					Collector to Tank Ratio – NPT200					
Location	Latitude	Solar Radiation (MJ/m ² /day)	Best Solar Month	Zone	610 340		610 430		per/1000 litres (RT1000-5000)	
					Min	Max	Min	Max	Min	Max
Darwin	12°	24.7	August	1	2.0	3.0	2.5	4.0	6	9.5
Cairns/ Townsville	17°	24.0	September	1	2.3	3.5	2.8	4.0	6	9.5
	19°									
Brisbane	27°	23.2	January	3	2.0	3.0	2.5	4.0	7	11
Perth	32°	28.9	January	3	2.0	3.0	2.3	3.5	6	9
Sydney	34°	23.5	December	3	2.2	3.5	2.7	4.0	7	10.5
Adelaide	35°	28.2	January	3	2.0	3.0	2.4	3.5	6	9
Canberra	35°	27.0	January	3	2.0	3.0	2.5	4.0	6	9.5
Melbourne	38°	24.4	January	4	2.0	3.1	2.5	4.0	6.3	10
Hobart	42°	23.6	January	4	2.4	3.5	3.0	4.5	7.5	11

TECHNICAL DATA

COMMERCIAL SOLAR PIPE SIZE / PUMP SELECTION / SPEED SETTING – RHEEM LOLINE															
Total Number Collectors	Combined Tank & Array Piping Length (m) ¹	Total Length (flow and return) Between Storage Tanks and Collector Array (m) ²													
		10	20	30	40	50	60	70	80	90	100	150	200		
15	30	DN20/20-60/1		DN20/20-60/2						DN20/20-60/3		DN20/32-80/2		DN20/32-80/3	
		DN25/20-60/1												DN25/20-60/2	
30	53+	DN25/20-45						-		-		-		-	
		DN25/20-60/2		DN25/20-60/3						-		DN25/32-80/2		DN32/20-60/2	
	53++	DN25/20-45						-		-		-		-	
		DN25/20-60/2		DN25/20-60/3						-		DN25/32-80/2		DN32/20-60/2	
45	63+	-		DN25/32-80/3				-		-		-		-	
	90++	DN32/20-45						DN32/20-60/3				DN32/20-60/3			
60		79+	-		DN32/32-80/3						-		-		-
	120++	-		DN40/20-45						-		DN40/20-60/3		DN40/32-80/3	
		DN32/32-80/3						-		-		-		-	
75	92+	-						DN40/32-80/3						-	
		-						DN50/20-45						-	
	111++	-						DN40/32-80/3						-	
		-						DN50/20-45						-	
90	105+	-		-						DN40/32-80/3		-		-	
	159++	-		DN40/32-80/3						-		-		DN50/32-80/2	
105		118+	-		-						DN50/20-60/3		-		-
	160++	-		-						-		-		DN50/32-80/3	
120	131+	-		-						-		-		DN50/32-80/3	
	215++	-		-						-		-		DN50/32-80/3	

¹ Total length of pipe inter-connecting tanks and collector arrays.

² Lineal length.

Notes: Pump selections are Grundfos. 20-60 = UPS20-60N, 20-45 = UP20-45N, 32-80 = UPS32-80N

UPS20-60N set to speed 3 can be substituted for a UP20-45N, but not the reverse

If actual number of panels falls between an array size, use the next biggest array

If actual pipe length between tanks and collectors falls between the lengths shown, use the next longest length

+ Parallel Array

++ Side by Side Array

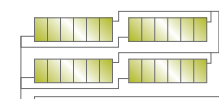
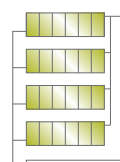

Typical Installation Commercial Solar Loline Double Array

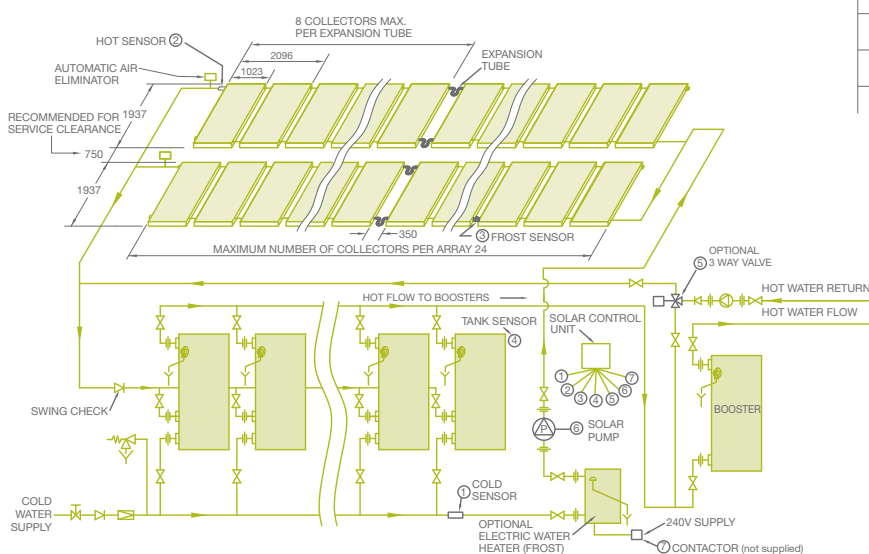

NPT200 COLLECTOR TECHNICAL DATA

Overall Dimensions H x W x D	mm	1941 x 1023 x 80
Aperture Area	m ²	1.86
Weight (empty /full)	kg	36/37
Fluid Capacity	Litres	1.5
Number of Risers		7
Absorber Material		Black Polyester Aluminium
Insulation		Polyester
Glazing		3.2mm Tempered Low Iron
Tray Material		Zincalume [®]

PREMIER HILINE INDIRECT SOLAR

SUITED TO SMALL ROOFTOP APPLICATIONS LIKE SPORTS FIELDS



SOLAR



LIGHTWEIGHT STAINLESS STEEL



ALL WEATHER & WATER



CAPACITY



MULTI-BOOST OPTIONS

The lightweight, simple commercial solar system.

LIGHTWEIGHT EFFICIENCY

The 300 litre stainless steel storage tank sits on the roof, reducing footprint on the ground and the thermosiphon design efficiently transfers energy from the collectors into the tank without the need for circulators and primary flow and return lines.



BUILT-IN FREEZE PROTECTION

Uses propylene glycol as the heat transfer fluid to deliver freeze protection to as low as -28°C.

IDEAL FOR SCALING WATER REGIONS

Because it's an indirect system, water never goes through the collector, making it ideal for scaling water areas.

*Conditions Apply: For full terms and conditions please contact Rheem or visit www.rheem.com.au/rheem/help/Warranties

SP2000 COLLECTOR TECHNICAL DATA		
Overall Dimensions H x W x D	mm	1996 x 1043 x 82
Aperture Area	m ²	1.88
Weight (empty /full)	kg	45/49
Fluid Capacity	Litres	3.8
Number of Risers		35
Absorber Material		Steel
Insulation		38mm Polyester
Absorber Surface		Black Polyester Powdercoat
Frame Material		Extruded Aluminium
Glass		3.2mm Tempered Low Iron

Typical Installation

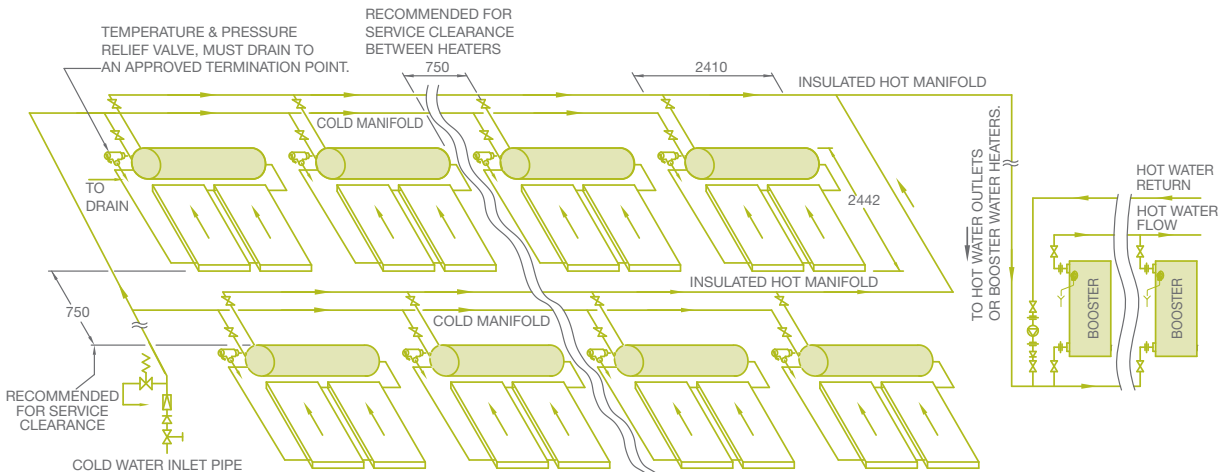

TECHNICAL DATA

MULTIPLE BOOST OPTIONS

When in tank energy is low or there's high hot water demand, the system can be boosted to ensure constant hot water supply. Electric heating unit bundles can be fitted via one of two flanges in RT tanks and a variety of fittings allow multiple configurations to be connected such as heat pump or gas water heater.

ELECTRIC BOOSTING

- Comes with an adjustable thermostat and visual temperature display
- Can be interlocked with BMS to maximise the solar contribution factor (SCF)

HEAT PUMP BOOSTING

If a Rheem commercial heat pump is chosen for boosting, the heat pump's high Coefficient of Performance will mean you'll achieve high renewable energy contribution. Additionally, Rheem horizontal discharge heat pump models can be stacked two high to reduce plant footprint.

REDUCE RUNNING COSTS AND ENERGY USE EVEN FURTHER WITH OPTIONAL 3-WAY VALVE

(Available with both Loline Solar and Heat Pumps)

The available energy in the storage tank can be monitored to maximise solar/heat pump energy use and reduce running costs.

When there's enough energy in the storage tank, the WaterMark Certified 3-way valve diverts building return water to the solar/heat pump storage. This passes through the in-line boost plant without further heating, using renewable energy to maintain ring main temperature.

Conversely, when there's not enough energy detected in the storage tank, the building return water is diverted through the in-line boost plant to maintain ring main temperature.



Rheem HS Series solar with electric boosting in the top of solar tanks. Katherine Hospital NT.

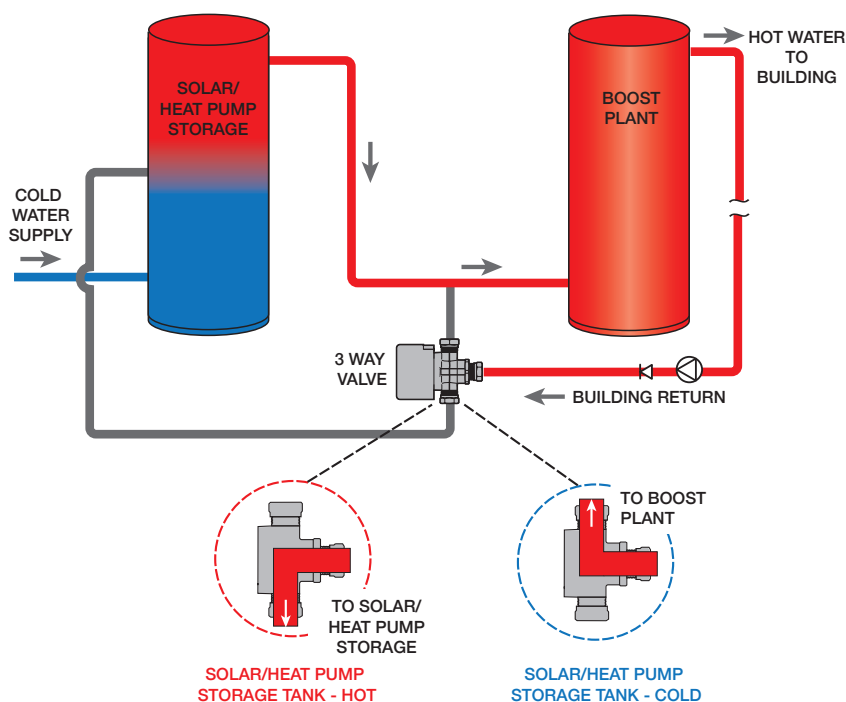

INSTALL TIPS

FIVE KEY TIPS FOR DELIVERING MAXIMUM PERFORMANCE FROM YOUR COMMERCIAL SOLAR SYSTEM.

1. Collectors should ideally face due north (in the southern hemisphere); facing as far as north-east and north-west will cause approximately 5% drop in operating efficiency.
2. Collectors should be inclined at approximately the latitude angle, however 15° either way is acceptable, but not less than 10° from the horizontal.

3. For flat roof installations, Rheem can supply variable pitch frames suitable for either one or two collectors with pre-set pitch angles of 20 to 30 degrees in 2.5 increments.
4. Metallic flow and return lines only **MUST** be used between the solar storage tanks and the collectors.
5. The pipe must be well insulated and sheathed if externally mounted. AS/NZS 3500.4 has guidelines specific to the zone and see the relevant Pipe Size and Pump Selection Table for the correct specification of pipe size.

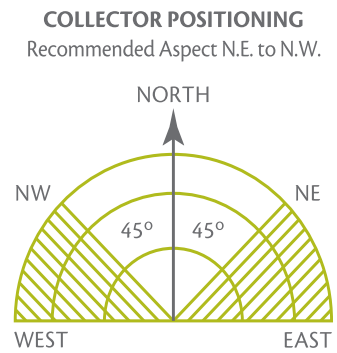

SOLAR FRAMES

VARIABLE PITCH STAND

Made from extruded aluminium section to offer excellent corrosion protection, Variable Pitch Stands can be mounted on flat or near flat roofs. The inclination angle can be set between 20 to 30 degrees in 2.5 increments.

WITH PITCH FRAME

For pitched roof installation, With Pitch Kits are available and are certified for use in wind regions C and D terrain category 2 up to a height of 10 metres.

NOTE

Rheem collector frames are designed in accordance with the relevant sections of AS/NZS 1170.0:2002, AS/NZS 1170.1:2002, AS/NZS 1170.2:2011, AS/NZS 4600:2005, AS/NZS 1664.1:1997, AS 1720.1:2010.

It is the responsibility of the designer to determine the actual wind load acting on the solar frame and collector assembly for the installation site and satisfy themselves as to the suitability of the frame and collector assembly.

Fixing of frames to building members must be designed by a structural engineer.

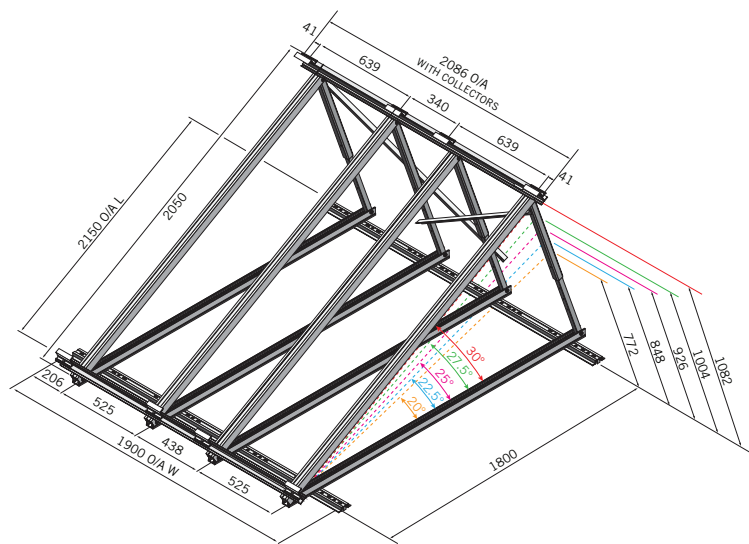

Variable Pitch Frame - 2 collectors 204026

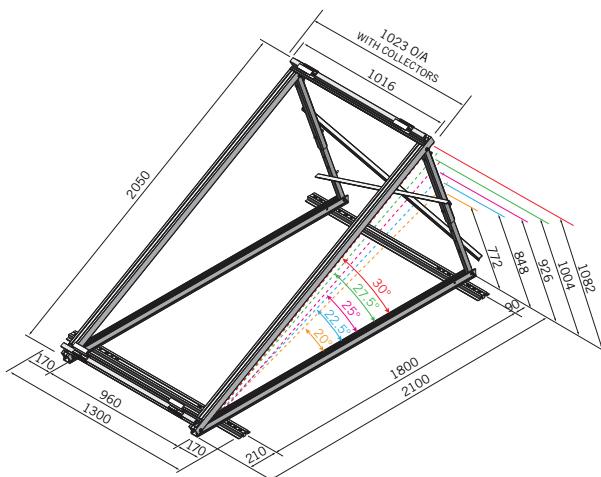

Variable Pitch Frame - 1 collector 204025

PUMP ACCESSORIES

FOR REDUCING ENERGY CONSUMPTION AND PROVIDING REDUNDANCY BACK UP



STAINLESS STEEL HEADERS



LOCKABLE



DUAL PUMP



TEMP CONTROL

Redi-set dual pump sets provide redundancy back up and are an ideal means of reducing energy consumption by timing the operation of the pumps when required

REDI-SET DUAL PUMP SETS

The systems incorporate Grundfos UPS 20-60N or UPS 32-80N stainless steel pump and manifolds. The complete system is mounted on a galvanized base frame with two holes on each side for easy mounting. The system includes non return valves and shut off valves integrated into a manifold arrangement to allow removal of one pump whilst the other is in operation.

An isolation valve should be installed in the suction and discharge lines for easy maintenance and removal (not supplied). Control panels are grey powder coated metal and are supplied with an electrical test certificate and wiring diagram inserted on the inside of the control panel door.

STANDARD MODEL

The Standard model has one switch Pump 1/Auto/Pump 2 mounted on the front panel with auto pump change over every twelve hours. The panel is key lockable.

DELUXE MODEL

The deluxe model incorporates separate Pump 1 and Pump 2 Auto/Off /Manual switches and red fault/green run indicator lights on the front panel.

This model incorporates auto pump duty change over on a time clock basis every twelve hours, run/alarm outputs for BMS connection and thermostatic control via external low voltage contacts.

Standard Model

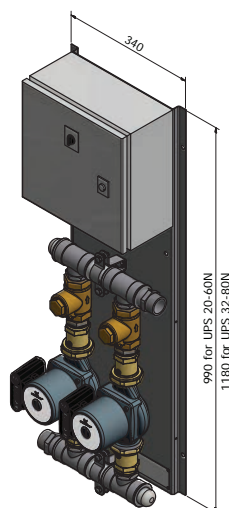

Deluxe Model

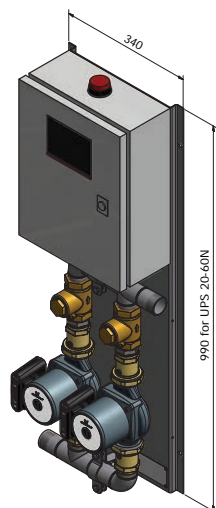

Note: Image of UPS 20-60N Deluxe Model is shown here



* 2 year warranty for grundfos pumps and 12 months for controller
* Conditions Apply: For full terms and conditions please contact Rheem or visit www.rheem.com.au/rheem/help/Warranties

DIMENSIONS AND TECHNICAL DATA TABLE

Circulator Type		UPS 20-60N		UPS 32-80N	
		Standard	Deluxe	Standard	Deluxe
Model Type		Standard	Deluxe	Standard	Deluxe
Model Number		99501270	99501272	99501271	99501293
Liquid Temperature Range	°C	2-110	2-110	2-110	2-110
Max. Ambient Temperature	°C	40	40	40	40
Max. Operating Pressure	kPa	1000	1000	1000	1000
Pipe Connection	BSP	R¾	R¾	R1¼	R1¼
Height x Length	mm	990 x 340	990 x 340	1180 x 340	1180 x 340
Net Weight	kg	24	27	31	33
Electrical Rating		240V/50Hz	240V/50Hz	240V/50Hz	240V/50Hz
Max. Current Amps		0.74	0.74	1.96	1.96
Pump Housing		Stainless Steel	Stainless Steel	Stainless Steel	Stainless Steel
Impeller		Composite, PES/PP	Composite, PES/PP	Composite, PES/PP	Composite, PES/PP
IP Rating of Pumps		IP44	IP44	IP44	IP44
IP Rating of Control Panels		IP54	IP54	IP54	IP54

TECHNICAL DATA

Pump curve UPS 20-60N

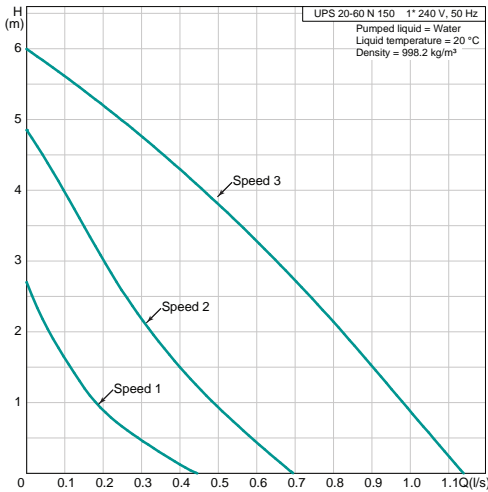

UPS 32-80N

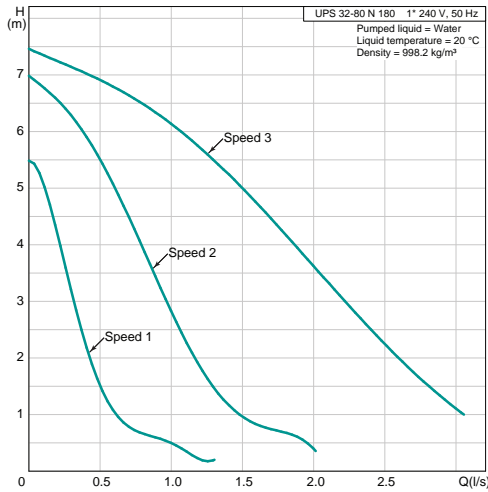

OUTDOOR COVER

Redi-Set pumps can be installed outdoor by installing outdoor covers supplied by Rheem. The part number for the outdoor cover is AQ2051057.

NOTE: The outdoor cover must be ordered separately for outdoor installation.

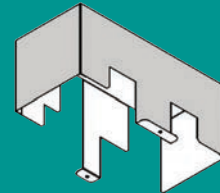

PUMP/C CONTROLLER

The Pump/C controller model 6060262-4 is used to control a system device for example pumps, 3-way valve, etc.

The controller senses temperature and controls the system device by an Operating Thermostat Sensor (Eliwell IC902).

FEATURES

- User display ensures accurate temperature control
- Adjustable thermostat sensor provides flexibility
- Built in Energy Cut Out Thermostat (ECO) ensures safety and reliability
- Double Pole Double Throw (DPDT) control relay with maximum current limit of 6A provides options for a variety of 240V or VFC applications



RHEEM EQUA-FLOW® MANIFOLDING

FLEXIBILITY AND REDUNDANCY



UP TO 10 STORAGE TANKS PER BANK



REDUNDANCY



INSTALLATION FLEXIBILITY

Increase storage and increase output with Rheem Equa-Flow

BIG ON WATER, BIG ON EFFICIENCY

If you need large volumes of hot water handled as efficiently as possible, you need to learn about Rheem Equa-Flow®.

With Rheem Equa-Flow® system, multiple water heaters or storage tanks of the same model can be manifolded to operate as one system.

This means both increased storage and increased output, with each water heater contributing an equal share of the work.

And it's very simple to add more water heaters to the bank, provided the plumbing is altered to keep the cold water inlet to the bank on the end opposite to the hot water outlet.

CIRCULATED FLOW AND RETURN SYSTEMS

The return line from the recirculation system should be connected to the common cold supply to the water heaters, after the main non-return valve and pressure limiting valve and before the first cold branch.

The circulator should be isolated by a gate valve on either side and a non-return valve installed after the circulator.

MINIMUM DISTANCE REQUIREMENTS

When you design and install a water heater system using the Rheem Equa-Flow® manifold system, it's important to observe the minimum distance requirements between water heaters and from obstructions.

This allows for correct operation of the water heaters and access for servicing and maintenance.



NOTES

1. In all installations, sufficient space must be left to enable servicing or removal of any water heater. Refer to the product tables for minimum centre to centre distances.
2. The maximum number of water heaters in any bank should be 8 for gas and electric models and 10 for storage tanks. However, several banks can be installed.
3. The hot water line from the manifold must leave from the opposite end to which the cold water line enters the manifold.
4. The hot water header, cold water header and cold water inlet pipe should be a minimum of DN32 pipe and be at least the next nominal diameter above the size of pipe required for the hot water outlet pipe to the system.
5. The cold water inlet pipe and the primary circuit piping should be the same size whichever is the largest.
6. The hot water outlet pipe and cold water inlet pipe should be the same size and sized according to the requirements of the particular installation.
7. A non-return valve, isolation valve and if required a pressure limiting valve and expansion control valve must be installed on the main cold water supply only, as shown in the diagram on the next page.
8. A full flow gate valve or ball valve must be installed on the branches to each water heater.
9. Cold water supply branches to each water heater must be identical. Hot water outlet branches from each water heater must be identical.
10. Non-return valves, pressure limiting valves or loose jumper valves must not be installed in the branch assemblies to each water heater, since preferential flow through one water heater will result.

TECHNICAL DATA

INSTALLATION LAYOUT MINIMUM DIMENSIONS						
Model	A	B	C	D	E ¹	F ¹
Electric						
613 050	685	435	250	0	1465	900
613 315	890	640	250	100	1680	900
616 315	890	640	250	100	1680	900
Storage						
610 340	890	640	250	100	1640	900
610 430	935	685	250	100	1685	900
Gas Indoor						
620 260	845	595	250	100	1670	900
624 265	860	610	250	100	1745	900
624 275	896	645	250	100	1780	900
Gas Outdoor						
630 260	920	595	420	420	1670	900
634 265	884	610	387	387	1745	900
634 275	896	645	370	370	1780	900

¹ A distance of 900mm is required for access, servicing and removal of the water heater.

Manifold arrangement

Hot header assembly

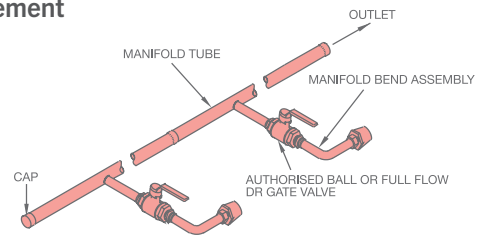

Cold header assembly

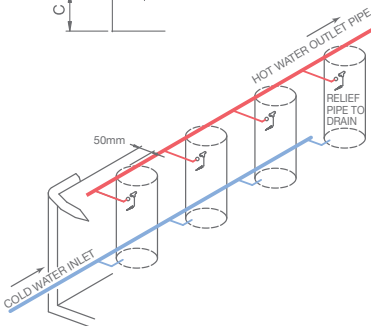
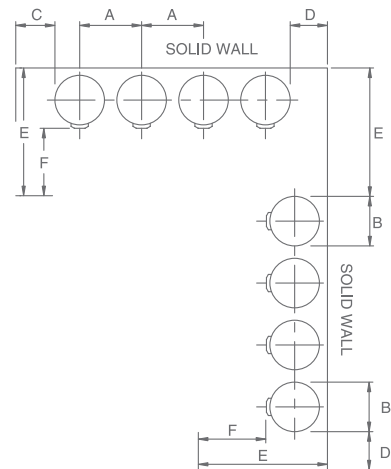
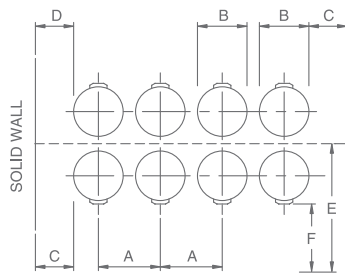
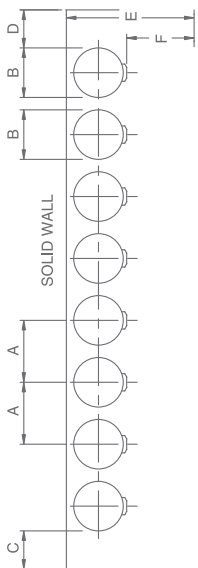
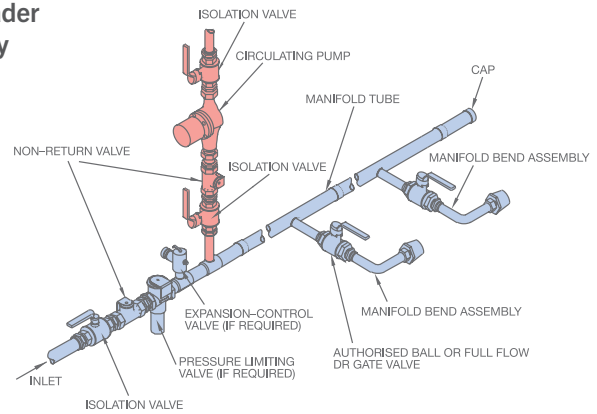

In line

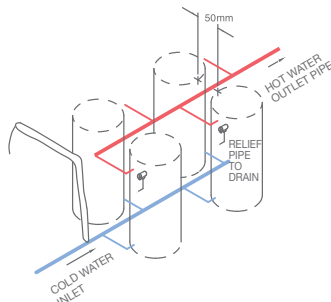

Back to back

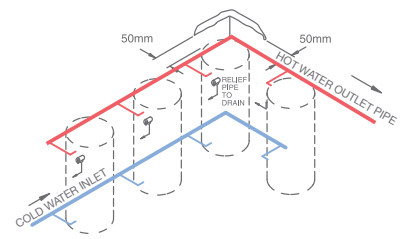

Angle

SIZING GUIDE

SELECTION GUIDE

To decide what size of water heater to install, follow the simple steps below:

1. First determine the peak demand period. (This may be spread over one or more hours. Refer to sizing guide.)
2. Next calculate the hot water requirements over the peak period. (Refer to sizing guide.)
3. Then select the water heaters that will satisfy the peak demand requirements. (One, two, three or more water heaters can be connected in parallel. Refer to performance chart.)

N.B: cold water temperature is needed to determine the appropriate temperature rise.

4. Ensure adequate space is available in the building for the installation. This is of extreme importance, particularly where a number of water heaters are connected in parallel. In allocating space for the installation, consideration should be given to the possible expansion of the system should the hot water demand increase. (See nominal dimensions table.)
5. Consider the advantages of using water heaters designed for outdoor installation ie. no secondary flue required; saving of internal space etc.
6. For an efficient mains pressure commercial or industrial installation, it is essential that the correct pipe sizes be installed.

RHEEM TECHNICAL ADVISORY SERVICE

This free Rheem service is available throughout Australia. A call to one of our water heating specialists will help you save your valuable time and effort. We also have a sizing tool available on our web site. For your next installation, commercial, industrial or home units, or for the unusual application where water must be supplied at a specific temperature, Rheem can show you several ways of maximising available space with the benefits of high performance and economical running costs.

Let Rheem solve your next hot water problem. Phone your local Rheem technical advisory service on **132 552**.

SIZING GUIDE

Application	Suggested peak period	Hot water requirements, at 60°C supply temperature (unless indicated)
Snack bars take-away food	1 to 2 hours 12 to 1pm or 12 to 2pm	Allow 3.1 litres for each meal. This covers cooking and washing, e.g. 200 meals over 2 hours = 620 litres. Note: water required at 82°C to meet regulations
Canteens, cafes, restaurants, hotel kitchens	1 to 2 hours 12 to 1pm or 12 to 2pm	Allow 5.5 litres for each 3 course meal. This covers cooking and washing. e.g. 200 meals over 2 hours = 1100 litres. Note: water required at 82°C to meet regulations
Holiday flats, hotels, motels, guest houses	1 hour 7.30am to 8.30am	Allow 20 to 25 litres per head over the peak hour, e.g. 40 guests = 1000 litres over 1 hour, for 4 and 5 star accommodation allow 30-45 litres per head
Apartments	1 hour 7:00am to 8:00am	Allow for each type of apartment in the building, e.g. studio = 25 litres, 1 bedroom apartment = 40 litres, two bedroom = 75 litres; three bedroom = 90 litres, four bedroom = 110 litres and a penthouse = 150 litres
Caravan parks camping areas	spread over 2 hours	Allow 20 litres per person. Average 4 persons per van, e.g. 30 vans = 120 people = 2400 litres, over 2 hours. Consider also no. of shower units available, allow maximum of 6 showers per hour per shower rose. In parks used mainly for long term holiday or residential purposes, the peak period may extend over a much longer time. The actual usage pattern should be ascertained
Hairdressing salons	3 to 4 hours	Each installation to be individually evaluated but as a guide allow 10 litres per customer. Fashion salons may use much more
Squash courts	spread over 4 hours	Allow 20 litres per player. Average 16 players per court over 4 hours e.g. 4 courts = 20 x 4 x 16 = 1280 litres over 4 hours
Office amenities	spread over 8 hours	Allow 3 to 4 litres per person per day. Shower seldom used. Peak usage allow 1.5 litres per person over 1 hour
Factory change rooms (light industry)	1 hour 4pm to 5pm	Average of 30% use showers. Allow 20 litres per head. Average of 70% use hand basins. Allow 3 litres per head. (This is equivalent to 8 to 9 litres per person)
Factory change rooms (heavy or dirty industry)	1 hour 4pm to 5pm	Allow 30 litres per head. Note: in some industries such as mining 50 litres per head may be necessary
Glass washing machines	usually over 2 hours	Determine quantity of glasses to be washed over peak period. Allow 3 glasses per litre of beer sold. Most machines require 7 litres of hot water per wash of 25 glasses and can handle one wash per minute. e.g. 1000 litres of beer over 2 hours 1000 x 3 x 7 litres ÷ 25 = 840 litres of hot water. Note: 1. Water required at 82°C to meet regulations. 2. Where beer consumption known in gallons multiply by 4.55 to convert to litres
Coin operated laundries	spread over 8 hours	Allow 70 litres per machine per hour, e.g. 6 machines 70 x 6 x 8 = 3360 litres over 8 hours. Large commercial laundries allow 10 litres per kg dry washing



Note: This sizing guide should be taken as an average only and individual assessment may be necessary.

Caution: In applications where it is known the peak hot water demand will be over a very short period (some showering periods in industry may be no longer than 30 minutes) then the storage and recovery rate of the water heater/s should be calculated for that time period only.

Note: Where hot water is being provided for dishwashing and glasswashing machines etc., it is advisable to check the hot water consumption of a unit with the manufacturer before specifying the water heater.

RHEEM AUSTRALIA PTY LTD

Sales 132 552

Service 131 031

rheem.com.au

1 Alan Street, Rydalmere, NSW 2116 Australia

ABN 21 098 823 511

RHEEM NEW ZEALAND LTD

Sales 0 800 657 336

Service 0 800 657 335

rheemnz.co.nz

475 Rosebank Road, Avondale, Auckland 1026

GST 80-960-239



Rheem Australia Pty Ltd

Head Office
1 Alan Street
Rydalmere NSW 2116
Australia

Postal
PO Box 7508
Silverwater NSW 2128
Australia

Rheem Commercial Sales call 132 552
Rheem Service call 131 031
www.rheem.com.au

® Registered Trademark of Rheem Australia Pty Ltd
™ Trademark of Rheem Australia Pty Ltd
™² Trademark of ABCB



Quality
ISO 9001

