

Owner's Guide and Installation Instructions

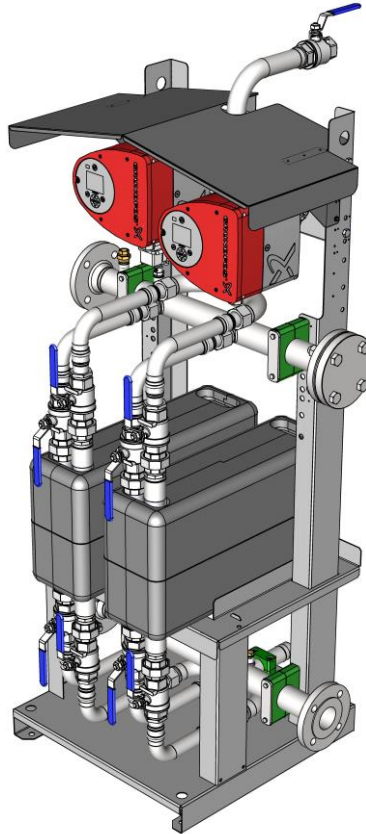

Rheem Crossflow™ Instantaneous Heat Exchange Delivery System



*This water heater must be installed and serviced by a qualified person.
Please leave this guide with a responsible officer.*

CONTENTS

CONTENTS	2
RHEEM CROSSFLOW WARRANTY – AUSTRALIA & NEW ZEALAND ONLY	4
THE RHEEM WARRANTY - GENERAL	4
DESCRIPTION	6
PUMP.....	6
HEAT EXCHANGE	6
SYSTEM INSTALLATION	10
CROSSFLOW PRIMARY CONNECTIONS	10
POTABLE WATER CONNECTIONS TO CROSSFLOW SYSTEM	12
MULTIPLE INSTALLATIONS	12
ELECTRICAL CONNECTIONS.....	13
BMS	13
WATER SUPPLIES	15
COMMISSIONING OF THE CROSSFLOW SYSTEM	17
SETTING THE DELIVERY TEMPERATURE.....	17
ADDITIONAL SETTINGS	18
PUMP WARNING AND ALARM CONDITION INDICATION.....	18
COMPONENT ADJUSTMENT PROCEDURES.....	20
COMMISSIONING THE CROSSFLOW PUMP.....	20
CHECKING OR ADJUSTING DELIVERY SKID PUMP PARAMETER SETTINGS	21
CONFIGURING DELIVERY SKID PUMP ASSIST MENU SETTINGS.....	21
ENABLING OR DISABLING DELIVERY SKID PUMP PARAMETER ADJUSTMENT	24
CHECKING CROSSFLOW PUMP ALARM & WARNING LOGS.....	27
SETTING THE GLOBE VALVE.....	28
CLEANING THE HEAT EXCHANGER.....	28
TROUBLE SHOOTING.....	28

**Notice to Victorian Customers from the
Victorian Building Authority.**

This heat exchange system must be installed by a licensed person as required by the Victorian Building Act 1993.

Only a licensed person will give you a Compliance Certificate, showing that the work complies with all the relevant standards. Only a licensed person will have insurance protecting their workmanship for 6 years. Make sure you use a licensed person to install this water heater and ask for your Compliance Certificate.

PATENTS

This water heater may be protected by one or more patents or registered designs.

TRADEMARKS

® Registered trademark of Rheem Australia Pty Ltd.
™ Trademark of Rheem Australia Pty Ltd.

NOTE: Every care has been taken to ensure accuracy in preparation of this publication. No liability can be accepted for any consequences, which may arise as a result of its application

RHEEM CROSSFLOW WARRANTY – AUSTRALIA & NEW ZEALAND ONLY

1. CROSSFLOW MODELS RD200, RD400, RD600 & RD800

THE RHEEM WARRANTY - GENERAL

- 1.1 This warranty is given by Rheem Australia Pty Limited ABN 21 098 823 511 of 1 Alan Street, Rydalmere New South Wales.
- 1.2 Rheem offer a trained and qualified national service network who will repair or replace components at the address of the water heater subject to the terms of the Rheem warranty. Rheem Service, in addition can provide preventative maintenance and advice on the operation of your water heater. The Rheem Service contact number is 131031, with Contact Centre personnel available 24 hours, 7 days a week to take your call and if necessary to arrange a service call for during normal working hours Monday to Friday (hours subject to change).
- 1.3 For details about this warranty, you can contact us on 131 031 or by email at warrantyenquiry@rheem.com.au (not for service bookings).
- 1.4 The terms of this warranty and what is covered by it are set out in section 2 and 3 and apply to water heaters manufactured after 1st March 2016.
- 1.5 If a subsequent version of this warranty is published, the terms of that warranty and what is covered by it will apply to water heaters manufactured after the date specified in the subsequent version.

2. TERMS OF THE RHEEM WARRANTY AND EXCLUSIONS TO IT

- 2.1 The decision of whether to repair or replace a faulty component is at Rheem's sole discretion.
- 2.2 Where a failed component or cylinder is replaced under this warranty, the balance of the original warranty period will remain effective. The replacement does not carry a new Rheem warranty.
- 2.3 Where the water heater is installed outside the boundaries of a metropolitan area as defined by Rheem or further than 25 km from either a regional Rheem branch office or an Accredited Rheem Service Agent's office, the cost of transport, insurance and travelling between the nearest branch office or Rheem Accredited Service Agent's office and the installed site shall be the owner's responsibility.
- 2.4 Where the water heater is installed in a position that does not allow safe or ready access, the cost of that access, including the cost of additional materials handling and/or safety equipment, shall be the owner's responsibility. In other words, the cost of dismantling or removing cupboards, doors or walls and the cost of any special equipment to bring the water heater to floor or ground level or to a serviceable position is not covered by this warranty.
- 2.5 This warranty only applies to the original and genuine Rheem water heater in its original installed location and any genuine Rheem replacement parts.
- 2.6 If the water heater is not sized to supply the hot water demand in accordance with the guidelines in Rheem's water heater literature, any resultant fault will not be covered by the Rheem warranty.
- 2.7 The Rheem warranty does not cover faults that are a result of:
 - a) Accidental damage to the water heater or any component (for example: (i) Acts of God such as floods, storms, fires, lightning strikes and the like; and (ii) third party acts or omissions).
 - b) Misuse or abnormal use of the water heater.
 - c) Installation not in accordance with the Owner's Guide and Installation Instructions or with relevant statutory and local requirements in the State or Territory in which the water heater is installed.
 - d) Connection at any time to a water supply that does not comply with the water supply guidelines as outlined in the Owner's Guide and Installation Instructions.
 - e) Repairs, attempts to repair or modifications to the water heater by a person other than Rheem Service or a Rheem Accredited Service Agent.
 - f) Faulty plumbing or faulty gas or power supply.
 - g) Failure to maintain the water heater in accordance with the Owner's Guide and Installation Instructions.
 - h) Transport damage.
 - i) Fair wear and tear from adverse conditions (for example, corrosion).
 - j) Cosmetic defects.
 - k) Ice formation in the waterways of a water heater: where the electricity supply has been switched off or has failed and the water heater has not been drained in accordance with the instructions; or due to an ambient temperature below -20°C (including wind chill factor).
- 2.8 If you require a call out and we find that the fault is not covered by the Rheem warranty, you are responsible for our standard call out charge. If you wish to have the relevant component repaired or replaced by Rheem, that service will be at your cost.
- 2.9 Subject to any statutory provisions to the contrary, this warranty excludes any and all claims for damage to furniture, carpet, walls, foundations or any other consequential loss either directly or indirectly due to leakage from the water heater, or due to leakage from fittings and/ or pipe work of metal, plastic or other materials caused by water temperature, workmanship or other modes of failure.

3. WHAT IS COVERED BY THE RHEEM WARRANTY FOR THE CROSSFLOW IS DETAILED IN THIS DOCUMENT

- 3.1 Rheem will repair or replace a faulty component of your Crossflow Delivery Skid if it fails to operate in accordance with its specifications as follows:

What components are covered	The period in which the fault must appear in order to be covered	What coverage you receive
All components	Year 1	Repair and/or replacement of the faulty component, free of charge, including labour.
Heat exchanger	Years 2 to 5	New parts, free of charge, with installation and labour costs being the responsibility of the owner.

4. ENTITLEMENT TO MAKE A CLAIM UNDER THIS WARRANTY

- 4.1 To be entitled to make a claim under this warranty you need to:
- Be the owner of the water heater or have consent of the owner to act on their behalf.
 - Contact Rheem Service without undue delay after detection of the defect and, in any event, within the applicable warranty period.
- 4.2 You are **not** entitled to make a claim under this warranty if your water heater:
- Does not have its original serial numbers or rating labels.
 - Is not installed in Australia.

5. HOW TO MAKE A CLAIM UNDER THIS WARRANTY

- 5.1 If you wish to make a claim under this warranty, you need to:
- Contact Rheem on 131031 and provide owner's details, address of the water heater, a contact number and date of installation of the water heater or if that's unavailable, the date of manufacture and serial number (from the rating label on the water heater).
 - Rheem will arrange for the water heater to be tested and assessed on-site.
 - If Rheem determines that you have a valid warranty claim, Rheem will repair or replace the faulty component in accordance with this warranty.
 - Any expenses incurred in the making of a claim under this warranty will be borne by you.

6. THE AUSTRALIAN CONSUMER LAW

- 6.1 Our goods come with guarantees that cannot be excluded under the *Australian Consumer Law*. You are entitled to a replacement or refund for a major failure and for compensation for any other reasonably foreseeable loss or damage. You are also entitled to have the goods repaired or replaced if the goods fail to be of acceptable quality and the failure does not amount to a major failure.
- 6.2 The Rheem warranty (set out above) is in addition to any rights and remedies that you may have under the *Australian Consumer Law*.

RHEEM AUSTRALIA PTY LTD
A.B.N. 21 098 823 511
www.rheem.com.au

FOR SERVICE TELEPHONE
131 031 AUSTRALIA
0800 657 335 NEW ZEALAND

DESCRIPTION

The Rheem Crossflow™ Delivery Skid is used to instantaneously transfer heat from the primary circuit to the secondary or domestic hot water circuit without the need for further storage. A temperature controlled variable speed circulator for the primary fluid circuit is used to regulate the rate of energy transfer to the potable water. The Rheem Crossflow controls allow heat input up to 90°C to be supplied on the primary side and accurate, reduced temperature to be delivered on the potable side. The temperature setting is factory set but can be adjusted on site as required. The system is factory assembled and furnished with 316L stainless steel manifolds and fittings, the steel frame is fully welded and hot dip galvanised for superior corrosion resistance. The Rheem Crossflow is available in four sizes and two of the same size unit can be connected where further redundancy or greater capacity is required.

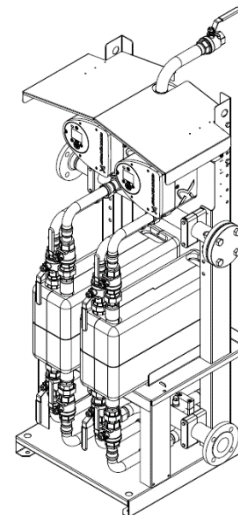

PUMP

The Rheem Crossflow is fitted with a temperature controlled variable speed pump. There are two options available, these being a single head pump or a dual head pump to provide duty/standby redundancy.

HEAT EXCHANGE

Each system is supplied with two WaterMark certified, 316L stainless steel single wall brazed plate-type heat exchangers. Each heat exchanger can be separately isolated and removed for individual maintenance, thus providing redundancy capability. The heat exchangers exhibit extremely low pressure loss and are insulated to maximise efficiency.



THIS HEAT EXCHANGE SYSTEM IS NOT SUITABLE FOR APPLICATIONS WHERE REFRIGERANTS ARE USED AS THE HEATING SOURCE, OR WHERE THE PRESSURE IN THE NON-POTABLE SIDE OF THE HEAT EXCHANGER IS LIKELY TO EXCEED THE PRESSURE IN THE POTABLE SIDE.

Table 1 – Crossflow System Specifications

Model		RD200	RD400	RD600	RD800	
Nominal Capacity	kW	200	400	600	800	
Parameters for Nominal Capacity Rating	Primary Side (non-potable)					
	Inlet Temp	°C	80	80	80	80
	Flow Rate	L/min	48	114	144	186
	Pressure Drop	kPa	24	47	36	36
	Secondary Side (potable)					
	Inlet/Outlet Temp	°C	15/65	15/65	15/65	15/65
	Flow Rate	L/min	57	115	172	223
Pressure Drop	kPa	37	47	51	48	
Dimensions	H x W x D	mm	1570 x 783 x 630			
Weight	kg	143	152	161	171	
Pipe Connections Primary Circuit	BSPF	RP1¼				
Pipe Connections Secondary Circuit		DN50 ISO EN 1092-1 11B PN40 Flange				
Max Operating Pressure Primary Circuit	kPa	1000*				
Max Operating Pressure Secondary Circuit	kPa	1400*				
Electrical Supply		230-240V 50/60Hz Hard Wired By Electrician				
Min Recommended Circuit Size	Amps	10				

*The maximum working pressure of each side of the system will be governed by the lowest operating pressure appliance connected to it. The potable water side (secondary side) must be higher than the non-potable side (primary side).

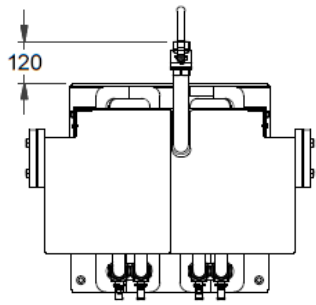

RHEEM MODEL No	MODEL TYPE	DIM. 'H 1'	DIM. 'H 2'	PRIMARY INLET 'P I'	PRIMARY OUTLET 'P O'	NETT WEIGHT
RD200D701	200 kW	877	1440	Rc1 1/4	R1 1/4	143 kg
RD400D701	400 kW	930	1493	Rc1 1/4	R1 1/4	152 kg
RD600D701	600 kW	993	1556	Rc1 1/4	R1 1/4	161 kg
RD800D701	800 kW	1056	1619	Rc1 1/4	R1 1/4	171 kg

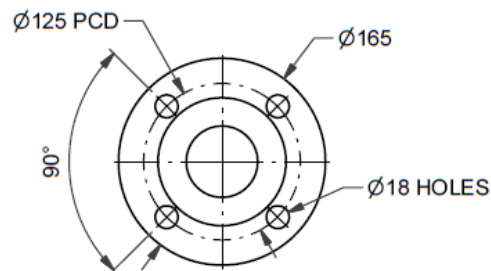
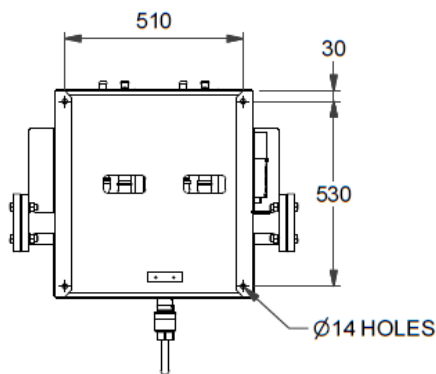
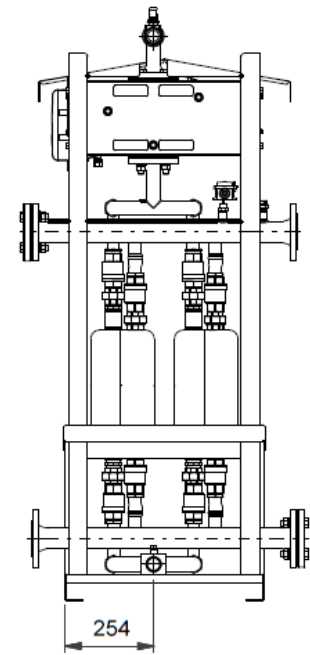
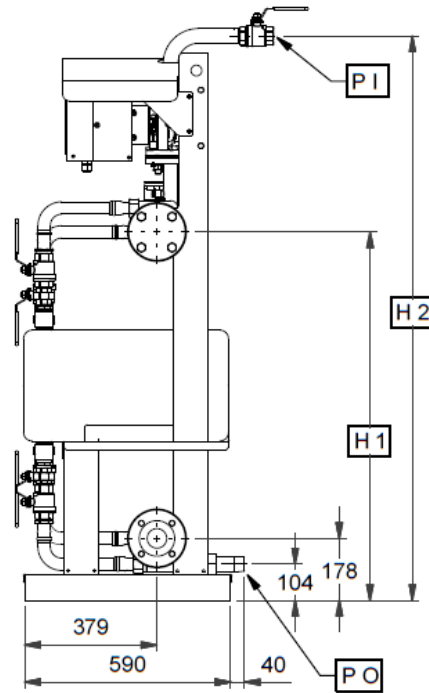
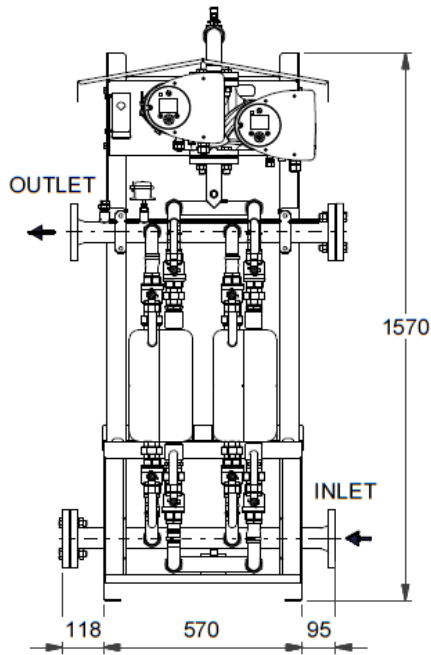

FLANGE DETAIL
(EN 1092-1/11/B1/DN50/PN40)

RHEEM DELIVERY SKID DIMENSIONAL DRAWING

Table 2 – Crossflow System Output

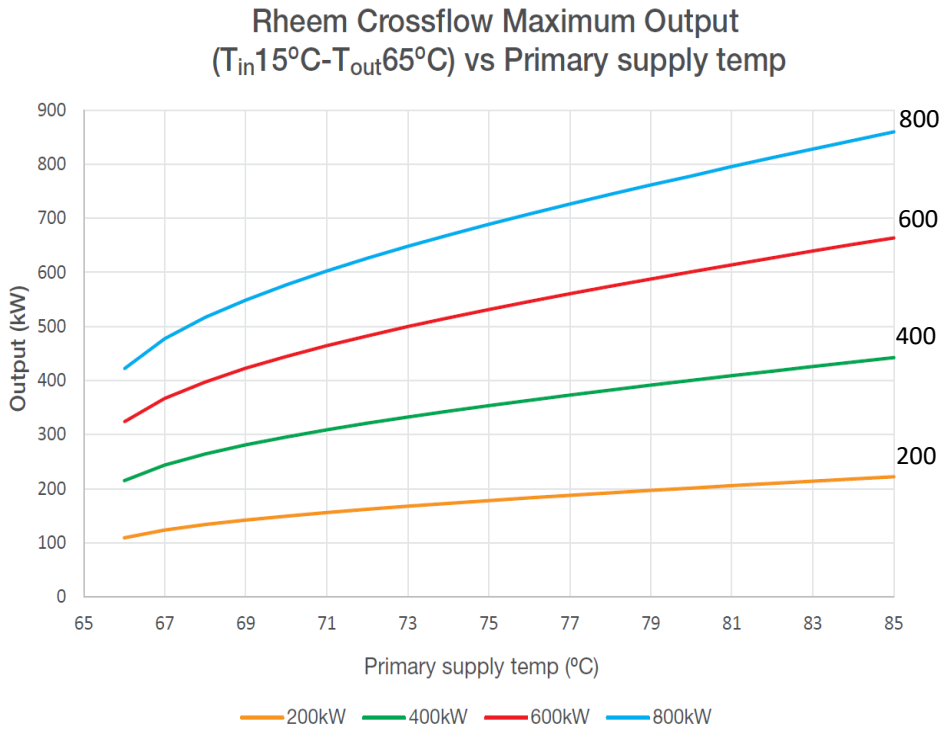
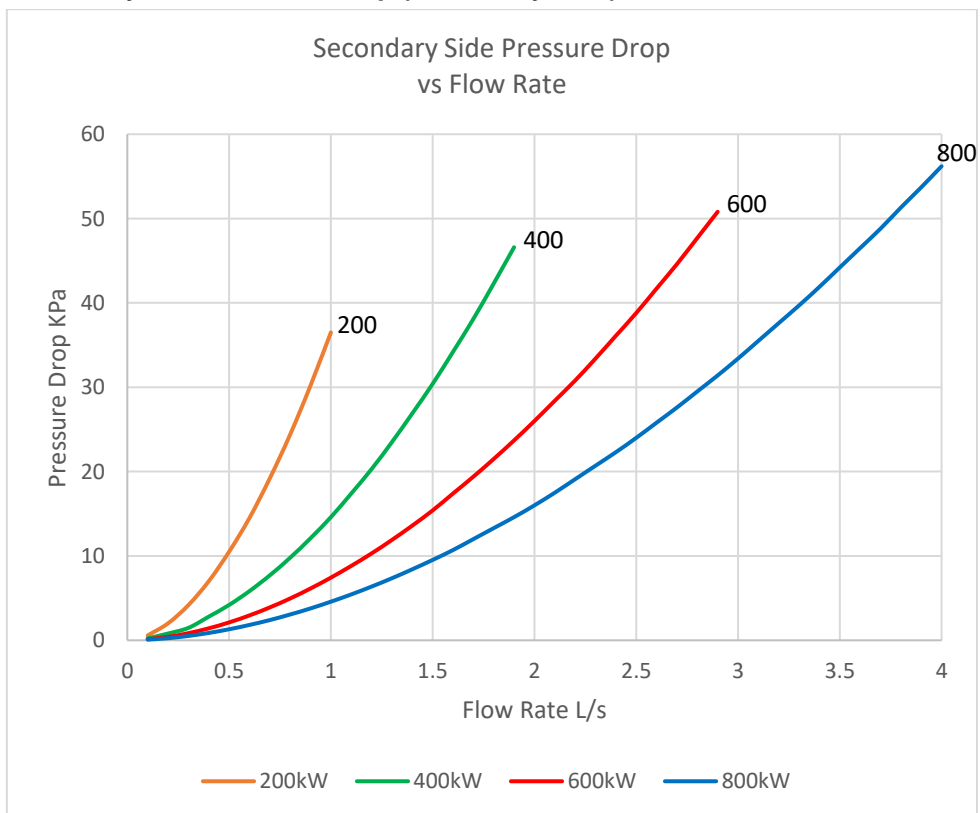

Table 3 – Crossflow System Pressure Drop (Secondary Side)



**Table 4 - Delivery Skid Secondary Side Flow Rate
for Varying Primary Supply Temperatures and Secondary Side Temperature Rise**

200kW						
Primary Temp	90	85	80	75	70	65
Output (kW)	270	215	200	190	160	100
Temp Rise	Secondary Side Flow Rate (L/min)					
65	60	47	44	42	35	
60	65	51	48	45	38	24
55	70	56	52	50	42	26
50	77	62	57	54	46	29
45	86	68	64	61	51	32
40	97	77	72	68	57	36
35	111	88	82	78	66	41

400kW						
Primary Temp	90	85	80	75	70	65
Output (kW)	500	450	400	365	300	200
Temp Rise	Secondary Side Flow Rate (L/min)					
65	110	99	88	80	66	
60	119	108	96	87	72	48
55	130	117	104	95	78	52
50	143	129	115	105	86	57
45	159	143	127	116	96	64
40	179	161	143	131	108	72
35	205	184	164	149	123	82

600kW						
Primary Temp	90	85	80	75	70	65
Output (kW)	740	680	600	535	450	300
Temp Rise	Secondary Side Flow Rate (L/min)					
65	163	150	132	118	99	
60	177	162	143	128	108	72
55	193	177	156	139	117	78
50	212	195	172	153	129	86
45	236	217	191	170	143	96
40	265	244	215	192	161	108
35	303	278	246	219	184	123

800kW						
Primary Temp	90	85	80	75	70	65
Output (kW)	940	870	800	695	580	400
Temp Rise	Secondary Side Flow Rate (L/min)					
65	207	192	176	153	128	
60	225	208	191	166	139	96
55	245	227	208	181	151	104
50	269	249	229	199	166	115
45	299	277	255	221	185	127
40	337	312	287	249	208	143
35	385	356	328	285	238	164

2 x 600kW						
Primary Temp	90	85	80	75	70	65
Output (kW)	1480	1360	1200	1070	900	600
Temp Rise	Secondary Side Flow Rate (L/min)					
65	326	300	265	236	198	
60	354	325	287	256	215	143
55	386	354	313	279	235	156
50	424	390	344	307	258	172
45	471	433	382	341	287	191
40	530	487	430	383	323	215
35	606	557	491	438	369	246

2 x 800kW						
Primary Temp	90	85	80	75	70	65
Output (kW)	1880	1740	1600	1390	1160	800
Temp Rise	Secondary Side Flow Rate (L/min)					
65	415	384	353	307	256	
60	449	416	382	332	277	191
55	490	453	417	362	302	208
50	539	499	459	398	333	229
45	599	554	510	443	369	255
40	674	624	573	498	416	287
35	770	713	655	569	475	328

SYSTEM INSTALLATION



IMPORTANT:

It is the responsibility of the plumber/installer that all installations are made in accordance with the building, electrical, and plumbing codes applicable in the installation region.

GENERAL REQUIREMENTS

Codes and Regulations

This water heater must be installed in compliance with the Plumbing Code of Australia (PCA).

Warning: – This water heater may deliver water at high temperature. Refer to the Plumbing Code of Australia, local requirements and these installation instructions to determine if additional delivery temperature control is required.

Warning: – For continued safety of this appliance, it must be installed, operated and maintained in accordance with the manufacturer's instructions.

Besides these instructions, all installations of the Rheem Crossflow system shall be carried out in accordance with:

- Local Regulations
- Municipal Building Codes
- Occupational Health, Safety & Welfare Regulations
- All plumbing work must be carried out by a qualified person and in accordance with the National Plumbing Standard AS/NZS 3500.4 and local authority requirements.
- All electrical work must be carried out by a qualified person and in accordance with AS/NZS 3000, as applicable under local regulations, and all local codes and regulatory authority requirements.
- In New Zealand the installation must also conform to the New Zealand Building Code.

Permits

All correct permits shall be obtained from the appropriate regulatory authorities.

Safety

Safety is the first priority in all installations. Please observe the safety warnings in this manual and other safety information provided on the HS Series system. Common safety precautions are:

- System must only be installed, commissioned or serviced by a qualified person.
- Depending on the model selected, the Crossflow system can be programmed by the installer to supply hot water at a temperature in excess of 50°C. We recommend that a temperature limiting device be fitted between the Crossflow system and the hot water outlets in any ablution and public areas such as bathrooms, ensuites or public amenities, to reduce the risk of scalding. A tempering valve may be required to comply with local requirements. Refer to the plumbing codes applicable in your area to determine if a temperature limiting device is required to minimize the risk of scalding.

SYSTEM CONFIGURATION

Refer to the **Application Guide** for specific system layouts.

CROSSFLOW PRIMARY CONNECTIONS

Position the Crossflow in the required location, as close to the heat source as possible and secure to the ground if required. Access to the Crossflow and removal of components is from the front, however sufficient clearance should be left on either side to allow for wrench access.

The Crossflow system is suitable for indoor or outdoor installation. In extreme climatic regions where ambient temperatures regularly exceed 40°C, it is recommended to install the Crossflow system out of direct sunlight.

The Crossflow requires a minimum of 1m head in order for the pump to function to specification. This requirement can be met in most situations. Minimum head may need to be considered when used with the primary circuit located in open vented or drain back systems.

Install the supplied line strainer on the primary flow to the Crossflow marked "Heating Source In". Pipe work must be cleared of foreign matter before connection and purged before attempting to operate the system. All olive compression fittings must use brass or copper olives.

Refer to [Delivery Skid Primary Side Pipe Sizing Chart on page 10](#) for pipe sizing between the heating source and the Crossflow. If more than 2 Crossflows are to be manifolded, or the pipe run exceeds a total of 10m flow and return between the Crossflow and the closest tank, or pipe material other than copper is being used, consult Rheem for appropriate pipe sizing.

Connect hot supply from heating source to the fitting marked "Heating Source In" on the Crossflow.

Install the supplied globe valve (not required with 800kW model) at the connection marked "Heating Source Out" on the Crossflow.

Connect from the fitting marked "Heating Source Out" on the Crossflow to the heating source return. Refer to the Application Guide for specific system layouts.

Provision for expansion of the primary side circuit must be included in the primary circuit. This may be in the form of pressure relief in the storage tank or primary flow and return circuit or via an expansion tank or vessel.

If multiple Delivery Skids are to be manifolded together to provide greater flow rate capability, [follow the diagram on page 11](#). Ensure equal-friction method is used when making the plumbing connections. If more than 2 Delivery skids are to be manifolded, or the pipe run exceeds a total of 10m flow and return, consult Rheem for appropriate pipe sizing.

Refer to [Potable Water Connections to Crossflow System on page 10](#) for potable water connection details.

Multiple Crossflow System Manifolding

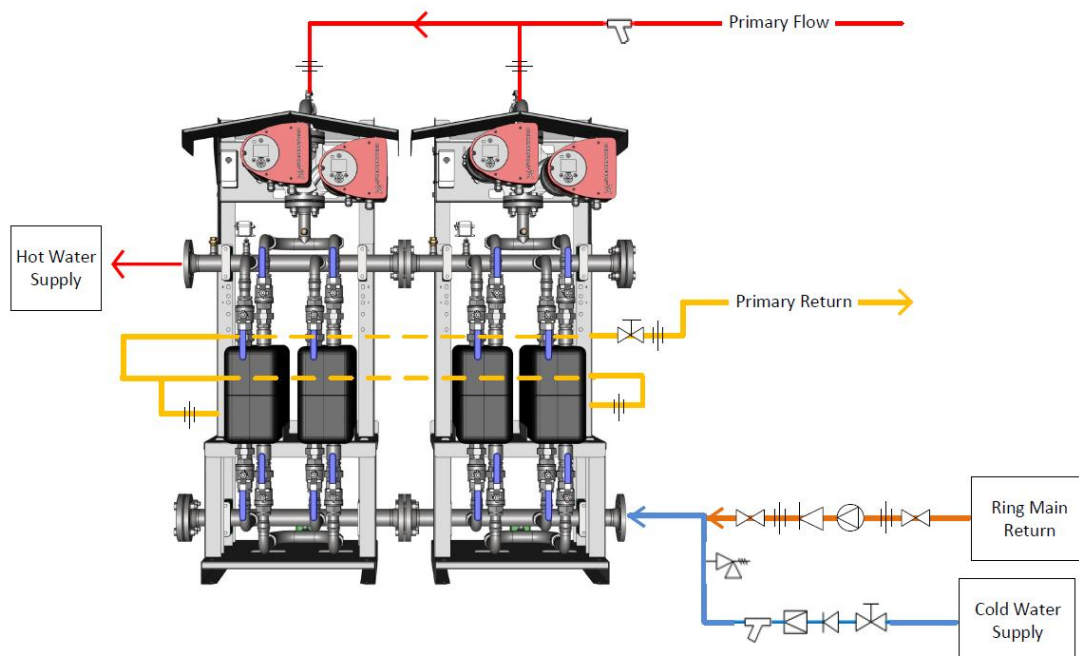

Table 5 - Crossflow System Primary Side Pipe Sizing

Crossflow system Model	Output (kW)	Pipe Size (copper) DN
200	200	40
400	400	50
600	600	65
800	800	80
2 x 600	1200	100
2 x 800	1600	100

POTABLE WATER CONNECTIONS TO CROSSFLOW SYSTEM

Refer to the [diagram on page 11](#) for potable water connections.

All pipe work must be cleared of foreign matter before connection and purged before attempting to operate the system.

COLD WATER SUPPLY

Install an isolation valve, non-return valve, line strainer and expansion control valve (ECV) (not supplied) on the cold water supply to the Crossflow.

The pressure relief setting of the ECV should be no greater than the maximum operating pressure of the lowest pressure rated component of the plumbing system, e.g. taps, valves, water heaters, other appliances, but **MUST NOT** exceed 1400kPa. The cold water supply pressure should be 20% below the ECV setting.

An acceptable arrangement is shown in the [diagram on page 11](#).

Connect the cold water supply at the flange marked "Potable In". The Crossflow system is supplied such that cold water enters on the right and leaves on the left. It is important that it remains this way to ensure accurate temperature reading at the hot water outlet.

HOT WATER SUPPLY

Depending on the model selected, the Crossflow system can be programmed by the installer to supply hot water at a temperature in excess of 50°C. We recommend that a temperature limiting device be fitted between the Crossflow system and the hot water outlets in any ablution and public areas such as bathrooms, ensuites or public amenities, to reduce the risk of scalding. A tempering valve may be required to comply with local requirements. Refer to the plumbing codes applicable in your area to determine if a temperature limiting device is required to minimize the risk of scalding.

Connect the hot water flow at the flange marked "Potable Out".

MULTIPLE INSTALLATIONS

If multiple Crossflows are to be manifolded together to provide greater flow rate capability, [follow the diagram on page 11](#). Ensure equal-friction method is used when making the plumbing connections. The potable water flanges may be joined together for up to two Crossflows. Systems greater than this require the potable water to be connected via a common header.

PIPE INSULATION

All hot water pipework shall be insulated to minimise heat losses. Use a minimum of 13 mm thick closed-cell polymer preformed pipe insulation or similar. Additionally, where temperatures reach -4°C for periods of greater than 8 hours, the potable cold water supply pipes shall be adequately insulated with at least 13 mm of closed-cell polymer insulation or equivalent. All insulation used shall be weatherproof and UV resistant if exposed, and protected from water ingress by tape, painting or sheathing.

ELECTRICAL CONNECTIONS

The Crossflow system is supplied pre-assembled and wired, however, requires connection of a correctly sized single phase power supply (including neutral 'N' and protective earth 'PE'). This power supply **SHALL BE** supplied from a distribution board (not supplied) that contains a circuit breaker and a main isolation switch to cut power to each pump individually for servicing purposes. If the distribution board is not located close to the Crossflow, then a separate isolation switch **SHALL BE** installed for each pump in the power supply directly before it.

All electrical work and permanent wiring must be carried out by a qualified person and in accordance with the Wiring Rules AS/NZS 3000 and all local codes and regulatory authority requirements.



Warning! Do not connect the power supply cable to the mains voltage power supply until all plumbing connections have been made and the system has been charged with water. Failure to do so can lead to electric shock and/or failure of the pump.

Table 6 - Crossflow System Electrical Requirements

Model	Power Supply	Max Current (Amps)	Min Circuit Size (Amps)
RD200	220 -240V AC / 50-60Hz	5	10
RD400			
RD600			
RD800			

Wire the power supply to terminals L, N, Earth within the Crossflow system pump controller housing. For dual pump systems, each pump is to be wired to the power supply separately with individual isolation switch.

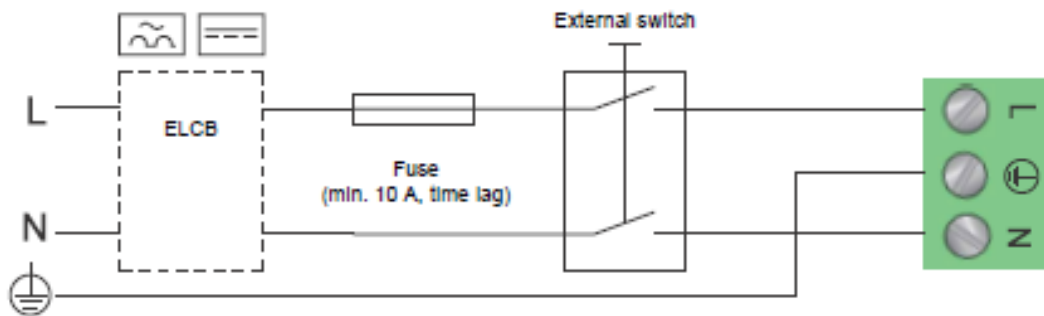

Crossflow System Wiring

BMS

Each pump has two integral signal relays and each relay has a set of volt free changeover contacts that can be utilised for BMS / Alarm indication. Each signal relay can be configured via the pump's control panel, a Grundfos GO remote or PC tool to display 'Alarm', 'Ready', or 'Operating' indication (refer to [Delivery Skid Pump Grundfos Eye & Pump Internal Signal Relay Contact Position Table](#) on page 17. Pumps are supplied configured with 'Operating' for signal relay 1 and 'Alarm' for signal relay 2.

Refer to the [wiring diagrams](#) on page 12 for BMS connections.

Data logging option is available for Crossflow System. Contact Rheem for further information.

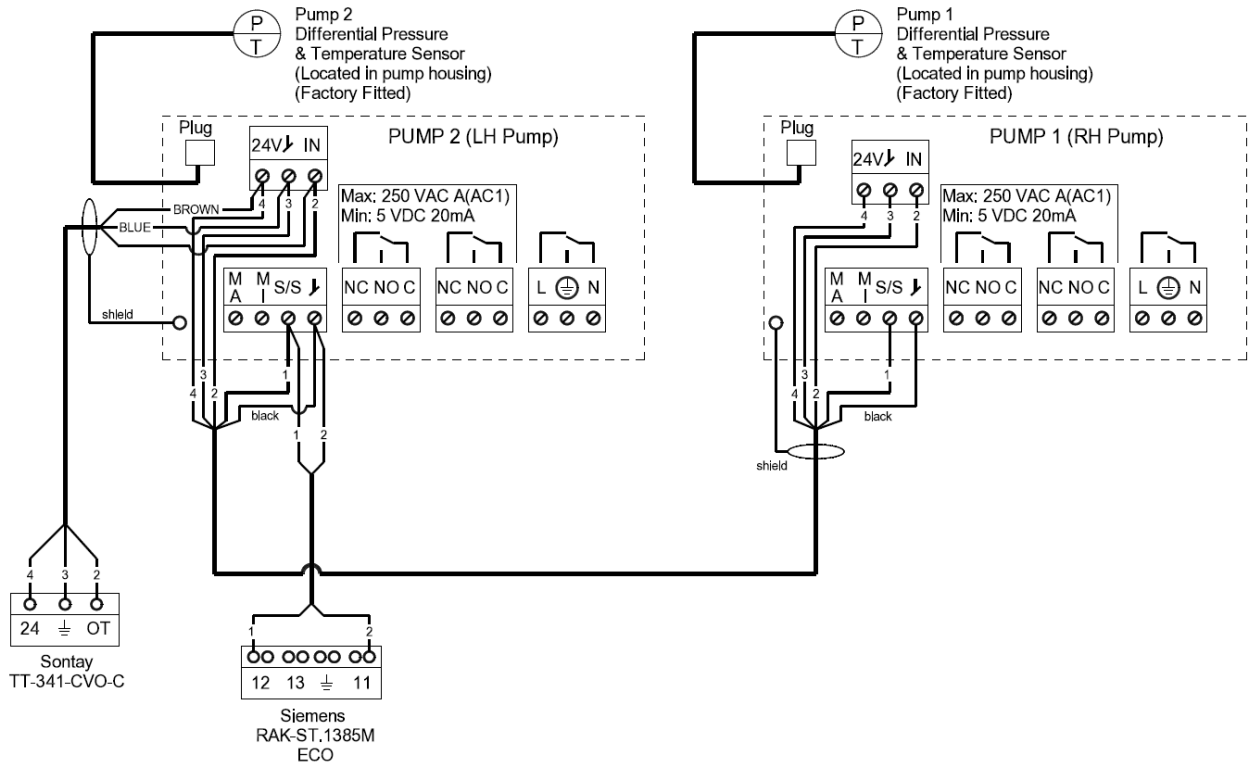

Wiring Diagram – Dual Head Pump System

WATER SUPPLIES

This Crossflow system must be installed in accordance with this advice to be covered by the Rheem warranty.

The Crossflow system is manufactured to suit the water conditions of most public reticulated water supplies. However, there are some known water chemistries which can have detrimental effects on the heat exchanger system and its operation and / or life expectancy. If you are unsure of your water chemistry, you may be able to obtain information from your local water supply authority. This heat exchanger system should only be connected to a water supply which complies with these guidelines for the Rheem warranty to apply.

CHANGE OF WATER SUPPLY

The changing or alternating from one water supply to another can have a detrimental effect on the operation and / or life expectation of a number of components in this heat exchanger system.

Where there is a changeover from one water supply to another, e.g. a rainwater tank supply, bore water supply, desalinated water supply, public reticulated water supply or water brought in from another supply, then water chemistry information should be sought from the supplier or it should be tested to ensure the water supply meets the requirements given in these guidelines for the Rheem warranty to apply.

SATURATION INDEX

The saturation index (SI) is used as a measure of the water's corrosive or scaling properties.

Where the saturation index is less than -1.0 , the water is very corrosive and the Rheem warranty does not apply to the heat exchanger system. In a corrosive water supply, the water can attack copper parts and cause them to fail.

Where the saturation index exceeds $+0.40$, the water is very scaling and an expansion control valve* must be fitted on the cold water line after the non-return valve for the Rheem warranty to apply to a Rheem storage tank. The Rheem warranty does not apply to the heat exchanger.

Water which is scaling may be treated with a water softening device to reduce the saturation index.

CHLORIDE AND PH

In a high chloride water supply, the water can corrode stainless steel parts and cause them to fail. Where the chloride level exceeds the limits shown in the table below the Rheem warranty does not apply to the Crossflow system.

CHLORIDE CONTENT	MAXIMUM TEMPERATURE			
	60°C	80°C	120°C	130°C
= 10 ppm	SS 304	SS 304	SS 304	SS 316
= 25 ppm	SS 304	SS 304	SS 316	SS 316
= 50 ppm	SS 304	SS 316	SS 316	Ti / 254 SMO
= 80 ppm	SS 316	SS 316	SS 316	Ti / 254 SMO
= 150 ppm	SS 316	SS 316	Ti / 254 SMO	Ti / 254 SMO
= 300 ppm	SS 316	Ti / 254 SMO	Ti / 254 SMO	Ti / 254 SMO
> 300 ppm	Ti / 254 SMO	Ti / 254 SMO	Ti / 254 SMO	Ti / 254 SMO

pH is a measure of whether the water is alkaline or acid. In an acidic water supply, the water can attack stainless steel parts and cause them to fail. Where the pH is less than the recommended level shown in the table of water content below, the Rheem warranty does not apply to the heat exchanger system.

Water with a low pH may be treated to raise the pH. The water supply from a rainwater tank in a metropolitan area is likely to be corrosive due to the dissolution of atmospheric contaminants.

SUMMARY OF WATER CHEMISTRY ADVICE AFFECTING THE RHEEM WARRANTY

The Crossflow system is not suitable for certain water chemistries. The following table is to be considered a guide to the corrosion resistance of stainless steels and brazing materials in tap water at room temperature. In the table a number of important chemical components are listed, however the actual corrosion is a very complex process influenced by many different components in combination.

Rheem's warranty will not cover any resultant faults if the water heater is connected at any time to a water supply that exceeds the limits listed in the table.

EXPLANATIONS: + Good resistance under normal conditions
 0 Corrosion problems may occur especially when more factors are valued 0
 - Use is not recommended

WATER CONTENT	CONCENTRATION (mg/l or ppm)	TIME LIMITS Analyze before	AISI 316	COPPER
Alkalinity (HCO ⁻)	< 70	Within 24 h	+	0
	70-300		+	+
	> 300		+	0/+
Sulphate ^[1] (SO ₄ ²⁻)	< 70	No limit	+	+
	70-300		+	0/+
	> 300		+	-
HCO ₃ ⁻ / SO ₄ ²⁻	> 1.0	No limit	+	+
	< 1.0		+	0/-
Electrical conductivity	< 10 µS/cm	No limit	+	0
	10-500 µS/cm		+	+
	> 500 µS/cm		+	0
pH [2]	< 6.0	Within 24 h	0	0
	6.0-7.5		+	0
	7.5-9.0		+	+
	>9.0		+	0
Ammonium (NH ₄ ⁺)	< 2	Within 24 h	+	+
	2-20		+	0
	>20		+	-
Chlorides (Cl ⁻) <i>Please also see table above</i>	<100		+	+
	100 - 200		+	+
	200 – 300		+	+
	>300		-	0/+
Free chlorine (Cl ₂)	<1	Within 5 h	+	+
	1 – 5		-	0
	>5		-	0/-
Hydrogen sulphide (H ₂ S)	<0.05	No limit	+	+
	>0.05		+	0/-
Free (aggressive) carbon dioxide (CO ₂)	<5	No limit	+	+
	5 – 20		+	0
	>20		+	-
Total hardness (°dH)	4.0 – 8.5	No limit	+	+
Nitrate ^[1] (NO ₃ ⁻)	<100	No limit	+	+
	>100		+	0
Iron ^[3] (Fe)	<0.2	No limit	+	+
	>0.2		+	0
Aluminium (Al)	<0.2	No limit	+	+
	>0.2		+	0
Manganese ^[3] (Mn)	<0.1	No limit	+	+
	>0.1		+	0

[1] Sulfate and nitrate work as inhibitors for pitting corrosion caused by chlorides in pH neutral environments

[2] Low pH (below 6) increases corrosion risk and high pH (above 7.5) decreases the corrosion risk

[3] Fe and Mn are strong oxidants and may increase the risk for localised corrosion on stainless steels.

SiO₂ above 150ppm increases the risk of scaling

COMMISSIONING OF THE CROSSFLOW SYSTEM

Potable and Non-Potable Water Circuit

All lines must be flushed of debris prior to filling the system. Failure to observe this requirement may lead to system blockage and/or underperformance. Check and clean the line strainers after flushing.

Fill the potable water circuit by opening the isolation valve at the cold water inlet connection on the potable water side of the Crossflow. Open a hot tap so air may be purged from within the system whilst filling. Close hot tap when all air has been expelled.

Fill the non-potable water circuit by opening the isolation valve at the “Heating Source In” and “Heating Source Out” connections on the non-potable water side of the Crossflow. Ensure air is purged from within the system whilst filling.

When full operational pressure is reached, ensure that all connections on both circuits are free of leaks. The non-potable water circuit **MUST BE** full and pressurised before any other tests are conducted to avoid potentially damaging the Crossflow pump. Failure to observe this precaution will result in warranty being void.



Switch on the electrical power to the Crossflow and follow the instructions below to set the temperature.

The Crossflow is programmed in the Rheem factory to operate as designed for optimum performance and is set at an appropriate temperature for the model Crossflow purchased. The only adjustment required may be to set the delivery temperature to other than what was delivered.

SETTING THE DELIVERY TEMPERATURE

The temperature entering the primary side of the Crossflow should be at least 5°C higher than the set temperature of the Crossflow in order for the Crossflow to perform to specification.

The Crossflow is supplied from the factory at 70°C. If adjustment is required:

- Press the Home button  to go to the Home screen on the pump.
- Press OK. The set point box will be highlighted.
- Press OK. The temperature will be highlighted
- Press OK. The first digit will be highlighted. Use Up/Down and Side button to select the desired set point.
- Press the Back button  to go back through the pages or the Home button to return to the home page.



Note: Dual head pump models require the temperature to be set on each pump individually

ECO Temperature Setting

Adjust the ECO high limit thermostat temperature to match the Crossflow set point temperature:

1. Undo the 4 screws on the ECO cover, and remove the cover. The screws are captive and will not fall out.
2. Using a flat bladed screwdriver, adjust the thermostat dial to the required Crossflow set point temperature.
3. Replace the cover and tighten the 4 screws.

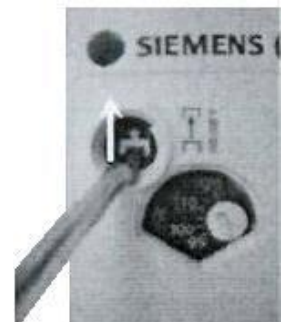

The high limit thermostat is a manual reset over temperature thermostat that will automatically switch off and shut down the Crossflow in the event of a temperature control or water flow fault.

Refer to Grundfos Magna manual supplied with Crossflow for other system options.







ADDITIONAL SETTINGS

The following section provides a brief overview of the **Home, Status, Settings and Assist** screens / menus, to assist with troubleshooting should the Rheem factory settings be inadvertently altered.

Note: The Crossflow system utilises settings different to those supplied by Grundfos. Activating 'Reset Factory Settings' will revert pumps to the Grundfos factory settings and the system will not function as designed.

Control Panel Display and Features



-  Grundfos Eye: Shows pump operating status
-  Home Button: To return to 'Home' screen
-  Back Button: To go back to previous screen
-  Up & Down Buttons: To navigate between parameters and sub parameters
-  Left & Right Buttons: To navigate between menus, parameter and digits
-  OK Button: To enter parameter values, save changed values and reset warnings / alarms

The display has four screens / menus indicated by four tabs at the top of the display.

- **'Home'** screen: For Rheem Crossflow Delivery Skids, the home screen is programmed to display the following information:
 - 'Actual value': Displays potable water delivery temperature as detected by the potable water temperature sensor.
 - 'Liquid temperature': Displays primary circuit liquid temperature.
 - 'Setpoint': Displays operating mode when pump has stopped or set point when pump is operating.
 - 'Flow rate': Displays primary circuit fluid flow rate through the heat exchanger.
- **'Status'** menu: Displays various operating and performance menu options for viewing only. Also shows pump model, serial number and software version information.
- **'Settings'** menu: Displays system parameters, sub parameters and their relevant settings. This is where parameter settings including potable water set point can be checked or adjusted (refer to [Delivery Skid Pump Parameter Settings Table](#) on page 23 for a list of parameters and their required settings).
- **'Assist'** menu: Provides set up procedures and informational menus (refer to [Configuring Delivery Skid Pump Assist Menu Settings](#) on page 19).

PUMP WARNING AND ALARM CONDITION INDICATION

Each pump head has a Grundfos eye that indicates the pumps current operating status. Refer to [Delivery Skid Pump Grundfos Eye & Pump Internal Signal Relay Contact Position Table](#) on page 17.











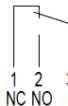
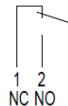

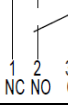
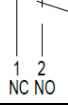
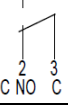
If a warning or alarm condition occurs, the pump's Grundfos eye will illuminate yellow (warning) or red (alarm) and the pump's display will also show a fault code.

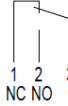
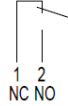
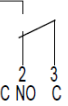
Available fault codes are as follows:

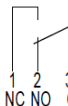
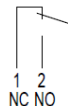
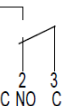
Warning Condition (Grundfos eye yellow indication)	
Code	Meaning
72	Internal fault
77	Communication fault twin head pump
84	Internal fault
88	Pump PT sensor signal outside range
93	External sensor signal outside range
155	Internal fault
157	Internal fault

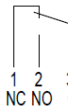
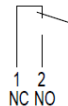
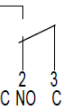
Alarm Condition (Grundfos eye red indication)	
Code	Meaning
10	Internal communication fault
29	Forced pumping
40	Under voltage 1
51	Blocked pump
57	Dry running
64	High motor temperature
72	Internal fault
74	Over voltage
75	Under voltage 2
84	Internal fault
155	Internal fault
157	Internal fault

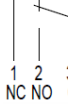
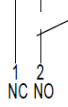
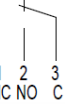
Delivery Skid Pump Grundfos Eye Indication & Pump Internal Signal Relay Contact Position Table

Grundfos Eye Indication		Description	Pump internal signal relay volt free changeover contact position according to output configuration type		
			Operating	Alarm	Ready
	No lights on	Power OFF – Pump not running			
	Two opposite green lights rotating	Power ON – Pump running			
	Two opposite green lights on solid	Power ON – Pump not running			
	One yellow light rotating	Warning – Pump running			
	One yellow light on solid	Warning – Pump stopped			
	Two opposite red lights flashing	Alarm – Pump stopped due to alarm condition			
	Centre green light 4 flash	Pump is indicating 'I am here' to Grundfos GO remote	Depends on pump status – Refer to 'Description' column		
	Centre green light flashing continuously	Pump is indicating 'Select me' to Grundfos GO remote			
	Centre green light on solid	Pump is selected and connected via Grundfos GO remote			

NOTES:

- A pump will operate as normal if a warning condition is present.
- A pump will cease to operate if an alarm condition is present.
- A warning or alarm condition will automatically reset when the fault is rectified.
- A warning or alarm condition can be manually reset by isolating the power supply to the Delivery Skid then restoring the power supply after the pump's Grundfos eye has extinguished (approximately 10 seconds).
- The last 5 occurring warning conditions and the last 5 occurring alarm conditions are logged in the pump's internal memory and can be viewed via the pump's control panel, a Grundfos GO remote or PC tool.

COMPONENT ADJUSTMENT PROCEDURES

COMMISSIONING THE CROSSFLOW PUMP

A Crossflow pump will only require commissioning when it is powered up for the first time (new installation or after being replaced as a spare part).

When powered up for the first time the pump will automatically enter a commissioning mode which will require certain parameters to be checked and adjusted.

Commissioning Procedure



The commissioning procedure MUST be performed in the order shown in the following procedure.

Note: For dual head pump models, perform steps 2 ~ 5 for each pump head in order i.e. step 2 for both pumps then step 3 for both pumps etc.

1. Ensure pump(s) are correctly installed and that the system is filled with primary and secondary circuit fluid.
2. Switch on power supply to pump(s).
 - If the pump display shows 'Language', the pump has automatically entered the initial setup mode procedure in which case proceed to step 3.
 - If the pump display shows 'Home' screen instead of 'Language' parameter, the initial setup mode procedure has already been performed in which case proceed directly to step 4.

3. Follow on screen prompts and enter values as follows:

Bold settings indicate where different to default settings.

Initial Setup Mode Parameters (in order of appearance)		
Parameter	Sub Parameter	Required Setting
Language	N/A	English GB
Date format	N/A	Current date
Time format	N/A	Current time
Setting of pump (select ' Go to assisted pump setup)	Control mode	Constant temp
	Controller gain Kp	1.0
	Control. integr. action time T1	8.0
	Adjust setpoint	65

4. Perform 'Setup of Analog Input' procedure (refer to '[Setup of Analog Input Procedure](#)' on page 20).
5. Check all parameter settings and adjust if required (refer to '[Checking or Adjusting Delivery Skid Pump Parameter Settings](#)' on page 1921).
6. If the Delivery Skid is a twin head pump model, configure the pumps for multipump operation via pump 1 control panel only (refer to '[Configuring Delivery Skid Pumps for Multipump Operation](#)' on page 21). Skip this step for single head pump models.

CHECKING OR ADJUSTING DELIVERY SKID PUMP PARAMETER SETTINGS

Pump parameter settings need to be checked when replacing a pump head or if correct pump operation is in doubt.

Parameter settings are checked and adjusted on the pumps control panel via the 'Settings' menu.

Refer to ['Delivery Skid Pump Parameter Settings Table'](#) on page 23 for a list of parameters and their required settings.



Pump parameter settings MUST be correctly set and for dual pump models, pump parameter settings MUST be correctly set for each pump head.







Activation of 'Settings > General settings > Return to factory settings' parameter resets the pump to Grundfos factory settings rendering the pump unsuitable for Delivery Skid operation. If this occurs, other non-viewable operating parameters MUST be reprogrammed by Rheem Service.

Note: If attempting to change a parameter setting and a message is displayed indicating that 'The pump is locked', parameter adjustment must then be 'Enabled' before any changes can be made. Refer to [Enabling or Disabling Delivery Skid Pump Parameter Adjustment](#) on page 22.

To enter the 'Settings' screen:

1. Press and release . The 'Home' screen will be displayed.
2. Press and release > two times. The 'Settings' menu will be displayed.

Whilst in the 'Settings' menu:

- Press and release \wedge or \vee to navigate between parameters.
- Press and release  to enter a parameter.
- Press and release \wedge or \vee to select a new parameter or change a selected digit value.
- Press and release < or > to select a parameter digit.
- Press and release  to confirm and save a parameter selection or digit value.
- Press and release  to go back to the previous screen.
- Press and release  to return to the 'Home' screen.

CONFIGURING DELIVERY SKID PUMP ASSIST MENU SETTINGS

Some 'Assist' menu settings need to be configured when replacing a pump head or if correct pump operation is in doubt.

Assist menu settings are configured on the pumps control panel via the 'Assist' menu.

Refer to ['Delivery Skid Pump Assist Menu Table'](#) on page 24 for a list of 'Assist' menu items and their required settings.

Most Assist menu items are informational, however there are two 'Assist' menu items that are critical for correct operation:

- 'Assist > Setup, analog input' (refer to ['Setup of Analog Input](#) on page 20).
- Assist > Multi-pump setup' – dual pump head models only (refer to [Configuring Delivery Skid Pumps for Multipump Operation](#)' on page 21).

Setup of Analog Input

'Setup of analog input' configures pump operation to be compatible with the potable water temperature sensor 0 ~ 10 V output.

















'Setup of analog input' MUST be correctly set and for deluxe models, 'Setup of analog input' MUST be correctly set for each pump head.

Note 1: Performing the following procedure will confirm 'Setup of analog input' settings even if the pump has already been correctly configured.

Note 2: If attempting to perform the following procedure and a message is displayed indicating that 'The pump is locked', parameter adjustment must then be 'Enabled' before any changes can be made. Call Rheem Service to assist.

Press and release . The 'Home' screen will be displayed.

1. Press and release **>** three times. The 'Assist' menu will be displayed.
2. Press and release **v** four times to highlight 'Setup, analog input'.
3. Press and release . The 'Setup, analog input' screen will be displayed.
4. Press and release **>**. The 'Function of analog input' screen will be displayed.
5. Press and release **^** or **v** to highlight 'Constant-temperature control' then press and release . 'Constant-temperature control' will flash blue once to confirm.
6. Press and release **>**. The 'Unit' screen will be displayed.
7. Press and release **^** or **v** to highlight '°C' then press and release . '°C' will flash blue once to confirm.
8. Press and release **>**. The 'Sensor range, min. value' screen will be displayed.
9. Press and release . The digits will change to the current setting.
10. Press and release **>** or **<** to select digits and press and release **^** or **v** to set digits to '0'.
11. Press and release  to confirm.
12. Press and release **>**. The 'Sensor range, max. value' screen will be displayed.
13. Press and release . The digits will change to the current setting.
14. Press and release **>** or **<** to select digits and press and release **^** or **v** to set digits to '100'.
15. Press and release  to confirm.
16. Press and release **>**. The 'Electrical signal' screen will be displayed.
17. Press and release **^** or **v** to highlight '0-10 V' then press and release . '0-10 V' will flash blue once to confirm.
18. Press and release **>**. The 'Controller description' screen will be displayed.
19. Press and release **>**. The 'Controller gain Kp' screen will be displayed.
20. Press and release . The digits will change to the current setting.
21. Press and release **>** or **<** to select digits and press and release **^** or **v** to set digits to '001.0'.
22. Press and release  to confirm.
23. Press and release **>**. The 'Control. integr. action time T1' screen will be displayed.
24. Press and release . The digits will change to the current setting.
25. Press and release **>** or **<** to select digits and press and release **^** or **v** to set digits to '0008.0'.
26. Press and release  to confirm.
27. Press and release **>**. The 'Adjust setpoint' screen will be displayed.
28. Press and release . The digits will change to the current setting.

-
29. Press and release > or < to select digits and press and release ^ or v to set digits to '065' (or required setpoint if different to 65°C).
 30. Press and release  to confirm.
 31. Press and release >. The 'Summary' screen will be displayed.
 32. Press and release  to confirm. 'Assist has been successfully carried out' will be shown on the display for a few seconds after which time the display will revert to the home screen.

Configuring Delivery Skid Pumps for Multipump Operation – Dual Pump Models Only

Multipump operation configures delivery skid pump heads 1 and 2 for duty sharing and redundancy purposes and applies to dual pump head models only.









The following procedure details how to configure multipump operation via pump 1 control panel (right hand pump). **All button operation is to be performed via pump 1 control panel unless specified otherwise.**

Note 1: Performing the following procedure will confirm multipump settings even if the pumps have already been correctly configured for multipump operation.

Note 2: If a pump Grundfos eye displays a yellow light indication and displays warning code 77 (communication fault twin head pump), perform steps 1 ~ 6 of the following procedure for that pump and select 'No multi-pump function' to reset the pump, then perform the entire procedure as detailed starting from step 1.

Note 3: If attempting to perform the following procedure and a message is displayed indicating that 'The pump is locked', parameter adjustment must then be 'Enabled' before any changes can be made. Refer to [Enabling or Disabling Delivery Skid Pump Parameter Adjustment](#) on page 22.

Press and release . The 'Home' screen will be displayed.

1. Press and release > three times. The 'Assist' menu will be displayed.
2. Press and release v three times to highlight 'Multi-pump setup'.
3. Press and release . The 'Setup of multi-pump system' screen will be displayed.
4. Press and release >. The 'Select multi-pump function' screen will be displayed.
5. *If 'Alternating operation' is highlighted:* Press and release . 'Alternating operation' will flash blue once to confirm.
If 'Alternating operation' is not highlighted: Press and release ^ or v until 'Alternating operation' is highlighted then press and release . If a 'Note' screen is displayed, press and release  again.
6. Press and release >. The 'Search for other pumps (1)' screen will be displayed.
7. Press and release >. The 'Search for other pumps (2)' screen will be displayed.
8. Press and release >. The 'Search for other pumps (3)' screen will be displayed.
9. Press and release . The pump will start searching for pump 2.
10. If after a few seconds a 'Note' screen is displayed on pump 2, press and release  on pump 2 otherwise skip this step (because pump 2 has already been previously detected/configured and this step is therefore not required).
11. When the search has completed, the 'Multipump system created' screen will be displayed with 'Grundfos' highlighted blue.
12. Press and release . Pump 2 Grundfos eye centre light will provide green 4 wink indication to confirm detection/configuration.
13. Press and release >. The 'Pump changeover, time' screen will be displayed.
14. Press and release ^ or v to highlight 'Energy-based changeover' then press and release . 'Energy-based changeover' will flash blue once to confirm.
15. Press and release >. The 'Pump changeover, energy' screen will be displayed.
16. Press and release >. The 'Summary' screen will be displayed.



-
17. Press and release . 'A multi-pump system has now been created successfully' will be shown on the display for a few seconds after which time the display will revert to the home screen.

ENABLING OR DISABLING DELIVERY SKID PUMP PARAMETER ADJUSTMENT

Disabling Parameter Adjustment (locking Procedure)

When parameter adjustment is disabled (locked), all menu screens can be viewed however parameter adjustment or 'Assist' menu setup procedures cannot be performed and if attempted, a message will be displayed indicating that 'The pump is locked'.





Perform the following procedure to disable (lock) parameter adjustment:

1. Navigate to 'Settings > General settings > Enable/disable settings' (refer to [Checking or Adjusting Delivery Skid Pump Parameter Settings](#) on page 19).
2. Press and release  to highlight 'Disable'.
3. Press and release  to confirm. 'Disable' will flash blue to confirm and parameter adjustment will be disabled (locked).

Enabling Parameter Adjustment (Unlocking Procedure)

If attempting to change a parameter setting or attempting to perform an 'Assist' menu procedure and a message is displayed indicating that 'The pump is locked', parameter adjustment must then be 'Enabled' (unlocked) before any changes can be made.

Perform the following procedure to temporarily enable (unlock) parameter adjustment:

1. Whilst in any screen, simultaneously press and hold  and  for five seconds. The screen will then display a message indicating that parameter changes can be temporarily performed at which time  and  can be released.
2. Perform any required parameter or 'Assist' menu changes.
3. After 5 minutes from last button operation, parameter adjustment will revert back to 'Disabled'.

Note: To permanently enable (unlock) parameter adjustment, perform step 1 and change 'Settings > General settings > Enable/disable settings' to 'Enable' then press and release  to confirm (refer to [Checking or Adjusting Delivery Skid Pump Parameter Settings](#) on page 19).

Delivery Skid Pump Parameter Settings Table

The following parameters are accessed via the 'Settings' menu (refer to [Checking or Adjusting Delivery Skid Pump Parameter Settings](#) on page 19).

Bold settings indicate where different to default settings.

Main Parameter	Sub Parameter	Required Setting	Notes
Setpoint	N/A	65	Current temperature setpoint as detected by the potable water temperature sensor.
Operating mode	N/A	Normal (refer to notes column)	Will display 'Normal' if pump is running or 'Stop' if pump is not running.
Control mode	N/A	Const.temp	Maintains a constant secondary circuit temperature according to 'Setpoint' parameter.
Controller settings	Controller gain Kp	1.0	Default operational parameter.
	Control.integr.action time Ti	8.0 sec	Default operational parameter.
FlowLimit	Enable FlowLimit function	Not Active	Not utilised.
	Set FlowLimit	14.4 m ³ /h	Default operational parameter.
Automatic Night Setback	N/A	Not active	Not utilised.
Relay outputs	Relay 1	Operation	Refer to ' Delivery Skid Pump Grundfos Eye & Pump Internal Signal Relay Contact Position Table ' on page 17 for more information on signal relays.
	Relay 2	Alarm	
Setpoint influence	External setpoint function	Not active	Not utilised.
	Temperature influence	Not active	Not utilised.
Bus communication	Pump number	Refer to notes column	Single Head Pumps: 1. Dual Head Pumps: 1 for right side pump and 2 for left side pump.
General Settings	Language	Refer to notes column	Factory set to 'English GB'. Can be set to another language if required.
	Set date and time	Refer to notes column	Set date format, date, time format and time.
	Units	SI or US units – SI ⁽¹⁾	Set to SI
	Enable/disable settings	Enable	Refer to Enabling or Disabling Delivery Skid Pump Parameter Adjustment on page 22.
	Delete history	Refer to notes column	Only utilised to delete recorded log and data information if required.

	Define home display	Refer to notes column	Select 'Home display type – List of data'. For 'Define home display contents' deselect all values then select in order ' Actual value ', ' Liquid temp ', ' Setpoint ' & ' Flow rate '.
	Display brightness	Refer to notes column	Utilised to adjust screen brightness.
	Return to factory settings	Refer to notes column ⁽²⁾	Resets all pump settings – Warning pump MUST be reprogrammed by Rheem Service.
	Run start-up guide	Refer to notes column	Activates start up guide. If activated, pump must be recommissioned (refer to Commissioning of the Crossflow on page15).

(1) Setting 'Units' > 'SI or US units' to 'SI' resets all 'Customise unit' values to default SI values.

(2) Resets pump to Grundfos settings rendering pump unsuitable for Delivery Skid operation. Other non-viewable operating parameters MUST be reprogrammed by Rheem Service.

Delivery Skid Pump Assist Menu Table













Refer to [Configuring Delivery Skid Pump Assist Menu Settings](#) on page 19.

Bold items indicate where different to default settings.

Assist Menu Item	Required Setting
Assisted pump setup	Do not use – Will change parameter settings. If utilised all parameter settings will need to be rechecked.
Setting of date and time	Can be utilised to change or set date and time instead of changing date and time via 'Settings' parameters.
Multi-pump - setup	Deluxe twin head models must be set for multi-pump operation. Refer to ' Configuring Delivery Skid Pumps for Multipump Operation ' on page 21.
Setup, analog input	Must be set to 'Constant temp control' > °C > sensor range min 0 max 100 > 0-10V > Kp 1.0 > Ti 8.0. Refer to 'Setup of Analog Input' on page 22.
Description of control mode	Informational only – Refer to Grundfos literature supplied with pump for more information.
Assisted fault advise	Informational only – Refer to Grundfos literature supplied with pump for more information.

CHECKING CROSSFLOW PUMP ALARM & WARNING LOGS

The following procedure details how to check Delivery Skid pump alarm and warning logs via the pump's control panel.

1. Press and release . The 'Home' screen will be displayed.
2. Press and release . The 'Status' menu will be displayed.
3. Press and release  four times to highlight 'Warning and alarm'.
4. Press and release . The 'Warning and alarm' screen will be displayed.
5. Press and release  or  to highlight 'Warning log' or 'Alarm log' then press and release  to enter the selected log list.
6. Press and release  or  to highlight the required log number then press and release . Details of the selected log will be shown.
7. Press and release  to go back to the previous screen.
8. Continue performing steps 6 and 7 and when all logs have been viewed, press and release  to return to the home screen.

Warning Condition (Grundfos eye yellow indication)	
Code	Meaning
72	Internal fault
77	Communication fault twin head pump
84	Internal fault
88	Pump PT sensor signal outside range
93	External sensor signal outside range
155	Internal fault
157	Internal fault

Alarm Condition (Grundfos eye red indication)	
Code	Meaning
10	Internal communication fault
29	Forced pumping
40	Under voltage 1
51	Blocked pump
57	Dry running
64	High motor temperature
72	Internal fault
74	Over voltage
75	Under voltage 2
84	Internal fault
155	Internal fault
157	Internal fault

SETTING THE GLOBE VALVE

Before testing the system, the water heating plant must be at the set temperature.

If installed, and connected to the inlet of the Crossflow (refer to Application Guide), turn on the building recirculation pumps. If the Crossflow is connected on a dead leg circuit, open some taps to represent the design minimum flow rate. The Crossflow will automatically activate to heat the water in the secondary circuit to the set temperature.

If the pump does not activate, or shuts down soon afterwards, this is an indication the flow rate is at the lower end of the Crossflow pump operating range. This will be the case typically with 200 to 600kW Delivery Skids, with a high heating source temperature and a high return water temperature (ie small temperature rise).

Adjusting the globe valve on the Crossflow primary side outlet towards the closed position will allow the Crossflow pump to operate at a lower flow rate and maintain better temperature control (not supplied with 800kW Crossflow).

Adjust the globe valve so that the pump remains on for a longer period of time.

CROSSFLOW PARAMETER SETTINGS

The Dual Head Pump Crossflow system is factory set to automatically switch pump operation in duty/standby mode and switch pumps in the event of pump failure. No further adjustments are required to the system.

The system is now completely commissioned. Explain operation and hand over to a responsible officer.

CLEANING THE HEAT EXCHANGER

Should the heat exchanger require cleaning, e.g. due to operation in hard water at high temperatures, it is possible to clean the heat exchanger. Use a tank with weak acid, 5% phosphoric acid or, if the heat exchanger is frequently cleaned, 5% oxalic acid. Remove from the system and circulate cleaning fluid through the heat exchanger, ideally at 1.5 times the normal flow rate and in reverse flow.

Flush the heat exchanger water ways with clean water and then before the final rinse with water, rinse with a solution of 1-2% sodium hydroxide (NaOH) or sodium bicarbonate (NaHCO₃) to neutralise all acid.

TROUBLE SHOOTING

Check the items below before making a service call. You will be charged for attending to any condition or fault that is not related to manufacture or failure of a part.

“Insufficient Water Temperature”

- Check for blown fuses or tripped circuit breakers.
- Has over-temperature lock-out occurred on the operating thermostats of the heating source?
- Temperature setting on the Crossflow incorrect.

“Insufficient Water Pressure”

- Check line strainers for blockage (if fitted).
- Check water pressure before and after pressure limiting valve (if fitted). If possible, adjust pressure setting if too low. Replace valve if necessary.
- Ensure pressure limiting valve is of sufficient capacity to meet the requirements of the application.
- Is pipe sizing adequate to suit the application?
- Check all valves, heat exchangers and pipework for fouling or blockage.