

Owner's Guide and Installation Instructions



Rheem Tankpak Series 3 Commercial Hot Water Systems

INSTALLER:

The **ONLY** suitable flue parts are certified Rheem coaxial flue components carrying the following label:

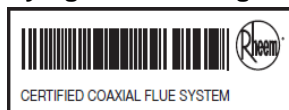

DO NOT use any other type of flue parts.
Carefully follow the Installation Instructions.

OPERATOR:

DO NOT OPERATE THIS WATER HEATER:

- Unless a certified Rheem coaxial flue system, venting to the outside through a certified Rheem terminal, is installed in accordance with the Installation Instructions.
 - If a loud continued vibration occurs during operation



Install a Rheem

*This water heater must be installed and serviced by a qualified person.
Please leave this guide with a responsible officer.*

⚠ Warning: Upon completion of the installation and commissioning of the water heater, leave this guide with a responsible officer or the householder. **DO NOT** leave this guide inside of the cover of the water heater, as it may interfere with the safe operation of the water heater or ignite when the water heater is turned on.

RESPONSIBLE OFFICER AND INSTALLER PLEASE NOTE

This Owner's Guide and Installation Instructions is shared for the Australian and New Zealand markets.

Where the content of this document is specific to either market, it is marked with either AU for Australian specific content or NZ for New Zealand specific content.

The 862627 models in natural gas and propane gas fuel types are sold in Australia.
References to Universal LP Gas models do not apply to the Australian market.

The 862627 models in natural gas and Universal LP Gas fuel types are sold in New Zealand.
References to propane gas models do not apply to the New Zealand market.

An electronic copy of these Owner's Guide and Installation Instructions can be downloaded from rheem.com.au and rheem.co.nz.

Rheem Australia Pty Ltd and Rheem New Zealand Limited are the suppliers of the Rheem range of continuous flow gas water heaters, manufactured in Japan by Paloma Co., Ltd., a world leader in water heater technology and manufacture.

PATENTS

This water heater may be protected by one or more patents or registered designs in the name of Rheem Australia Pty Ltd, Rheem New Zealand Limited or Paloma Co., Ltd.

TRADEMARKS

® Registered trademark of Rheem Australia Pty Ltd., or Rheem New Zealand Limited.
™ Trademark of Rheem Australia Pty Ltd., or Rheem New Zealand Limited.

Note: Every care has been taken to ensure accuracy in preparation of this publication. No liability can be accepted for any consequences, which may arise as a result of its application.

CONTENTS

This booklet contains important information about your new water heater, including terms of the Rheem warranty.

We recommend you read pages 8 to 18, and the terms of the Rheem warranty on pages 4 to 5.

The other pages are intended for the installer but may be of interest.

CONTENTS.....	3
RHEEM CONTINUOUS FLOW GAS WATER HEATER WARRANTY – AUSTRALIA AND NEW ZEALAND ONLY	4
SAFETY, WARNINGS, INSTALLATION NOTES	6
ABOUT YOUR WATER HEATER	8
WATER SUPPLIES.....	13
SAVE A SERVICE CALL.....	16
TANKPAK SERIES 3 – TECHNICAL SPECIFICATIONS	19
INSTALLATION – WATER HEATER	26
CONNECTIONS – PLUMBING.....	37
FLUEING	44
CONNECTIONS – ELECTRICAL	61
COMMISSIONING.....	64
APPENDIX 1 – LIFTING AND ROOF INSTALLATION	81

RHEEM CONTINUOUS FLOW GAS WATER HEATER WARRANTY – AUSTRALIA AND NEW ZEALAND ONLY

Continuous Flow Gas Water Heater TANKPAK SERIES 3 MODELS TP3 and TZ3

1. The Rheem Warranty – General

- 1.1 This warranty is given by Rheem Australia Pty Limited ABN 21 098 823 511 of 1 Alan Street, Rydalmere New South Wales, and in New Zealand by Rheem New Zealand Limited of 475 Rosebank Road Avondale Auckland 1026, the supplier of Rheem continuous flow gas water heaters, manufactured by Paloma Co., Ltd., a world leader in water heater technology and manufacture.
- 1.2 Rheem offer a trained and qualified national service network who will repair or replace components at the address of the water heater subject to the terms of the Rheem warranty. Rheem Service, in addition can provide preventative maintenance and advice on the operation of your water heater. The Rheem Service contact number in Australia is available 7 days a week on 131 031 with Service personnel available to take your call from 8am to 8pm daily (hours subject to change) or in New Zealand on 0800 657 335.
- 1.3 For details about this warranty, you can contact us in Australia on 131 031 or by email at warrantyenquiry@rheem.com.au (not for service bookings), or in New Zealand on 0800 657 335 or by email at rheem@rheem.co.nz (not for service bookings).
- 1.4 The terms of this warranty and what is covered by it are set out in section 2 and 3 and apply to water heaters manufactured after 1st February 2017.
- 1.5 If a subsequent version of this warranty is published, the terms of that warranty and what is covered by it will apply to water heaters manufactured after the date specified in the subsequent version.

2. Terms Of The Rheem Warranty And Exclusions To It

- 1.6 The decision of whether to repair or replace a faulty component is at Rheem's sole discretion.
- 1.7 Where a failed component or cylinder is replaced under this warranty, the balance of the original warranty period will remain effective. The replacement does not carry a new Rheem warranty.
- 1.8 Where the water heater is installed outside the boundaries of a metropolitan area as defined by Rheem or further than 25 km from either a regional Rheem branch office or an Accredited Rheem Service Agent's / Centre's office, the cost of transport, insurance and travelling between the nearest branch office or Rheem Accredited Service Agent's office and the installed site shall be the owner's responsibility.
- 1.9 Where the water heater is installed in a position that does not allow safe or ready access, the cost of that access, including the cost of additional materials handling and/or safety equipment, shall be the owner's responsibility. In other words, the cost of dismantling or removing cupboards, doors or walls and the cost of any special equipment to bring the water heater to floor or ground level or to a serviceable position is not covered by this warranty.
- 1.10 This warranty only applies to the original and genuine Rheem water heater in its original installed location and any genuine Rheem replacement parts.
- 1.11 If the water heater is not sized to supply the hot water demand in accordance with the guidelines in Rheem's water heater literature, any resultant fault will not be covered by the Rheem warranty.
- 1.12 The Rheem warranty does not cover faults that are a result of:
 - a) Accidental damage to the water heater or any component (for example: (i) Acts of God such as floods, storms, fires, lightning strikes and the like; and (ii) third party acts or omissions).
 - b) Misuse or abnormal use of the water heater.
 - c) Installation not in accordance with the Owner's Guide and Installation Instructions or with relevant statutory and local requirements in the State or Territory in which the water heater is installed.
 - d) Connection at any time to a water supply that does not comply with the water supply guidelines as outlined in the Owner's Guide and Installation Instructions.
 - e) Repairs, attempts to repair or modifications to the water heater by a person other than Rheem Service or a Rheem Accredited Service Agent / Centre.
 - f) Faulty plumbing or faulty gas or power supply.
 - g) Failure to maintain the water heater in accordance with the Owner's Guide and Installation Instructions.
 - h) Transport damage.
 - i) Fair wear and tear from adverse conditions (for example, corrosion).
 - j) Cosmetic defects.
 - k) Ice formation in the waterways of a water heater: where the electricity supply has been switched off or has failed and the water heater has not been drained in accordance with the instructions; or due to an ambient temperature below -20°C (including wind chill factor).
- 1.13 If you require a call out and we find that the fault is not covered by the Rheem warranty, you are responsible for our standard call out charge. If you wish to have the relevant component repaired or replaced by Rheem, that service will be at your cost.
- 1.14 Subject to any statutory provisions to the contrary, this warranty excludes any and all claims for damage to furniture, carpet, walls, foundations or any other consequential loss either directly or indirectly due to leakage from the water heater, or due to leakage from fittings and/ or pipe work of metal, plastic or other materials caused by water temperature, workmanship or other modes of failure.
- 1.15 In New Zealand this warranty excludes to the extent permissible all implied warranties set out in the Sale of Goods Act 1908 (New Zealand) and all guarantees set out in the Consumers Guarantees Act 1993 (New Zealand) to the extent that the goods are acquired for the purpose of resupply in trade consumption in the course of a process of production or manufacture or repairing or treating in trade other goods or fixtures on land.

Continuous Flow Gas Water Heater TANKPAK MODELS TP3 and TZ3

3. What Is Covered By The Rheem Warranty For The Water Heaters Detailed In This Document

- 1.16 Rheem will repair or replace a faulty component of your water heater if it fails to operate in accordance with its specifications as follows:
- 1.17 For storage tank warranty, refer to storage tank Owners Guide

What components are covered	The period in which the fault must appear in order to be covered	What coverage you receive
All components	Year 1	Repair and/or replacement of the faulty component, free of charge, including labour.
CFWH (only if the water heater is installed in a single-family domestic dwelling with a preset outlet temperature setting not exceeding 75°C)	Years 2 & 3	Repair and/or replacement of the faulty component, free of charge, including labour.
The heat exchanger (if water heater is installed in a single-family domestic dwelling with a preset outlet temperature setting not exceeding 75°C)	Years 4 to 10	Replacement heat exchanger, free of charge. Installation and repair labour costs are the responsibility of the owner.
The heat exchanger (if the water heater is installed with a preset outlet temperature setting not exceeding 75°C, and is <u>not</u> installed in a single-family domestic dwelling)	Years 2 to 5	Replacement heat exchanger, free of charge. Installation and repair labour costs are the responsibility of the owner.

4. Entitlement To Make A Claim Under This Warranty

- 1.18 To be entitled to make a claim under this warranty you need to:
 - a) Be the owner of the water heater or have consent of the owner to act on their behalf.
 - b) Contact Rheem Service without undue delay after detection of the defect and, in any event, within the applicable warranty period.
- 1.19 You are **not** entitled to make a claim under this warranty if your water heater:
 - a) Does not have its original serial numbers or rating labels.
 - b) Is not installed in Australia or New Zealand.

5. How To Make A Claim Under This Warranty

- 1.20 If you wish to make a claim under this warranty, you need to:
 - a) Contact Rheem on 131031 in Australia or 0800 657 335 in New Zealand and provide owner's details, address of the water heater, a contact number and date of installation of the water heater or if that's unavailable, the date of manufacture and serial number (from the rating label on the water heater).
 - b) Rheem will arrange for the water heater to be tested and assessed on-site.
 - c) If Rheem determines that you have a valid warranty claim, Rheem will repair or replace the water heater in accordance with this warranty.
- 1.21 Any expenses incurred in the making of a claim under this warranty will be borne by you.

6. The Australian Consumer Law

- 1.22 Our goods come with guarantees that cannot be excluded under the Australian Consumer Law. You are entitled to a replacement or refund for a major failure and for compensation for any other reasonably foreseeable loss or damage. You are also entitled to have the goods repaired or replaced if the goods fail to be of acceptable quality and the failure does not amount to a major failure.
- 1.23 The Rheem warranty (set out above) is in addition to any rights and remedies that you may have under the *Australian Consumer Law*.

7. The Consumer guarantees act 1993 (New Zealand)

- 1.24 Our goods come with guarantees that cannot be excluded under the Consumer Guarantees Act 1993 (New Zealand). If the goods fail to comply with the applicable guarantees set out under the Consumer Guarantees Act 1993 (New Zealand) being the guarantee as to acceptable quality, the guarantee as to correspondence with description or the guarantee as to repair and parts, or if the goods fail to comply with any express guarantee given by Rheem, then you are entitled to a replacement or refund and for compensation for any other reasonably foreseeable loss or damage.
- 1.25 The Rheem warranty (set out above) is in addition to any rights and remedies that you may have under the Consumer Guarantees Act 1993 (New Zealand).

<p>RHEEM AUSTRALIA PTY LTD, A.B.N. 21 098 23 511 www.rheem.com.au www.rheem.co.nz</p>	<p>FOR SERVICE TELEPHONE 131 031 AUSTRALIA 0800 657 335 NEW ZEALAND</p>
--	---

SAFETY, WARNINGS, INSTALLATION NOTES

It is important you read the following safety and warnings information.

SAFETY

For your safety do not operate this water heater before reading this instruction booklet.

This water heater is supplied with a temperature controller, hi-limit control and a temperature and pressure relief valve. These devices must not be tampered with or removed. The water heater must not be operated unless each of these devices is fitted and is in working order.

Improper installation, adjustment, alteration, service or maintenance can cause injury or property damage. For assistance or additional information consult your Rheem distributor, qualified installer, or Rheem® Service agent.

The Rheem warranty can become void if relief valves or other safety devices are tampered with or if the installation is not in accordance with these instructions.

If the power supply cord or electrical conduit to the water heater is damaged, it must be replaced by an authorised person in order to avoid a hazard. The power supply cord and plug must be replaced with a genuine replacement part available from Rheem. Phone your nearest Rheem Service Department or Accredited service Agent to arrange for an inspection.

Do not use the water heater if any part has been under water. Immediately call Rheem Service or Accredited service Agent to arrange for an inspection.

⚠ WARNINGS

This water heater must be installed in compliance with the Plumbing Code of Australia (PCA).

Warning: – This water heater may deliver water at high temperature. Refer to the Plumbing Code of Australia, local requirements and these installation instructions to determine if additional delivery temperature control is required.

Warning: – For continued safety of this appliance, it must be installed, operated and maintained in accordance with the manufacturer's instructions.

- This water heater is only intended to be operated by persons who have the experience or the knowledge and the capabilities to do so.
- This water heater is not intended to be operated by persons (including children) with reduced physical, sensory or mental capabilities, or lack of experience and knowledge. Children should be supervised to ensure they do not interfere with the water heater.
- The water heater uses 240 Volt AC electrical power for operation of the control systems. The removal of the access cover(s) will expose 240 V wiring. They must only be removed by an authorised or qualified person.
- DO NOT modify this water heater.
- DO NOT use or store **flammable materials** in or near this water heater. Flammable liquids (such as petrol), combustible materials (such as newspapers) and similar articles must be kept well away from the water heater and the draught diverter or flue terminal.
- DO NOT spray **aerosols in the vicinity of** the water heater whilst it is operating. Gases from some aerosol sprays corrosive when drawn into a flame.
- DO NOT store **swimming pool chemicals, household cleaners**, etc., near the water heater.
- DO NOT place articles on or against this water heater or in contact with the flue terminal. Ensure the flue terminal is not obstructed in any way at any time.
- DO NOT use Propane / Butane gas mixtures in a Propane model. A Propane model is designed to operate on Propane only. The use of Propane / Butane mixture, such as automotive LPG fuel, in a Propane model is unsafe and can cause damage to the water heater.
- DO NOT operate with panels, covers or guards removed from the water heater.
- DO NOT enclose this water heater (applies to external installations only).



INSTALLATION NOTES

This water heater must be installed:

- by a qualified person,
- in accordance with the installation instructions,
- in compliance with the Plumbing Code of Australia (PCA) and Plumbing Standard AS/NZS 3500.4,
 - This water heater is designed for indoor installation only.
 - This water heater is intended to be permanently connected to the water mains and not connected by a hose-set. A braided flexible hose or semi-flexible connector may be used for connection to the water heater, where permitted by AS/NZS 3500.4.
- in compliance with the Gas Installations Standard AS/NZS 5601.1,
- in compliance with all local codes and regulatory authority requirements,
- in New Zealand also conforming to Clauses G11, G12 and H1 of the New Zealand Building Code.

Installation and commissioning requirements and details for the installing plumber and licensed electrical worker are contained on **pages 26 to 64**.

What To Do If You Smell Gas?

- DO NOT try to light any gas appliance.
- DO NOT touch any electrical switch.
- TURN OFF the gas supply at the gas meter immediately, call your gas supplier or licensed gasfitter.

NOTE: Some gases are heavier than air and it may be necessary to check for gas leaks at floor level.

ABOUT YOUR WATER HEATER

DESCRIPTION

Rheem Tankpak Series 3 combines the benefits of mains pressure and continuous flow water heating. Manifoldded banks of continuous flow water heaters (CFWH) meet the peak demand requirements whilst the storage tank provides buffer for peak simultaneous demands.

A controller is used to control the CFWH by sensing the temperature within the storage tank and controlling a pump in the primary circuit which in turn causes the CFWH to fire or cease firing. A deluxe controller is also equipped to control a pump in the secondary circuit (building ring main) by sensing the temperature in the building return line.

The Rheem Tankpak Series 3 is a bank of 2 to 18 continuous flow water heaters factory manifoldded in parallel. All components are factory assembled on a galvanised steel frame suitable for either wall or floor mounting.

This water heater is designed for the purpose of heating potable water. Its use in an application other than this may shorten its life.

Depending on model, the Rheem Tankpak Series 3 is suitable for:

- Outdoor or indoor installation
- Natural Gas, Propane (LPG) (Australia only) or ULPG (New Zealand only)
- Wall or floor mounting
- Inline or back to back installation

The Rheem Tankpak Series 3 is a fully engineered system, completely factory assembled and tested prior to despatch, requiring only minimal on-site work to be completed, as detailed below:

1. Installation & service connections to the package.
 - a) Gas in
 - b) Cold water in
 - c) Interconnection of storage tank/s (supplied separately)
 - d) Hot water out
 - e) Co-axial flueing for individual internal water heaters (supplied separately)
 - f) Building return circulator (model dependant)
 - g) 240V/1Ph/50Hz 10-30A power supply to the package (model dependant)
2. Final commissioning (refer to [page 64](#)).

WATER HEATER OPERATION

Automatic safety controls are fitted to the water heater to provide safe and efficient operation.

HOW HOT SHOULD THE WATER BE?

The water heater is factory supplied pre-set to maintain a tank temperature set point of 65°C, with a tank differential of 3 °C and has a maximum preset outlet temperature setting of 82°C. For applications requiring sanitising temperatures, the outlet temperature should be set at 82°C. The minimum recommended preset outlet temperature setting is 60°C.

If the water heater is installed as part of a circulated hot water flow and return system in a building, the preset outlet temperature setting of the water heater must be set to at least 60°C.

Note: The preset outlet temperature setting of this water heater cannot be adjusted by a building occupant. The setting can only be adjusted by the installer, Rheem Service or their nearest Accredited Service Agent.

Note: AS 3498 requires that a water heater provides the means to inhibit the growth of Legionella bacteria in potable water. When this water heater is used as an in-series booster for a solar water heater it can satisfy this AS 3498 requirement provided it is energised and the booster preset outlet temperature setting is 70°C or higher.

If this water heater is installed as part of a solar water heater system, the system can deliver water at temperatures from 58°C up to 75°C and possibly higher depending upon the model of solar water heater installed.

HOTTER WATER INCREASES THE RISK OF SCALD INJURY

This water heater can deliver water at temperatures which can cause scalding.

We recommend and it may be required by regulations that an approved temperature limiting device be fitted into the hot water piping to ablution, bathing and public areas when a Tankpak Series 3 water heater is installed. This will keep the water temperature below the maximum permitted by AS/NZS 3500.4 to these areas.

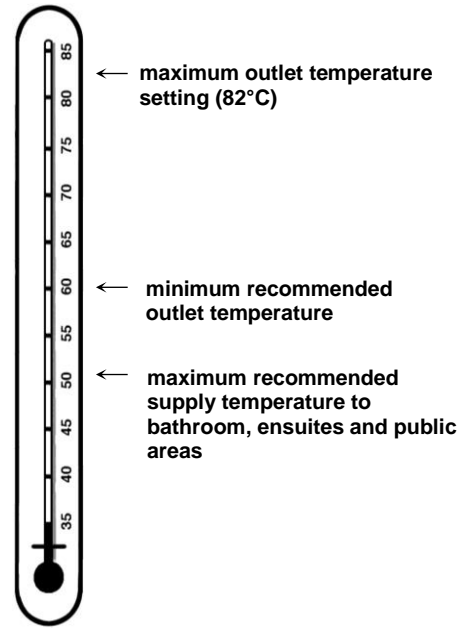

SAFETY

 **Warning:** For continued safety of this water heater it must be installed, operated and maintained in accordance with the Owner’s Guide and Installation Instructions.

The Rheem warranty may not cover faults if relief valves or other safety devices are tampered with or if the installation is not in accordance with these instructions.

The water heater uses 240 Volt AC electrical power for operation of the control systems, pump and the combustion fan. The removal of the front panel of the water heater, pump or controller will expose 240 V wiring. It must only be removed by a qualified person.

If installed outdoors, the power lead from the water heater must be plugged into a weatherproof electrical outlet. Take care not to touch the power plug with wet hands.

This water heater is supplied with temperature sensors, a FlameSafe® protection system and a pressure relief valve. These devices must not be tampered with or removed. The water heater must not be operated unless each of these devices is fitted and is in working order.

If the power supply cabling cord, plug or conduit is damaged, it must be replaced by a qualified person in order to avoid a hazard. The power supply cord and plug must be replaced with a genuine replacement part available from Rheem. Phone Rheem Service or their nearest Accredited Service Agent to arrange for an inspection.

- Do not store **flammable or combustible materials** near the water heater. Flammable liquids (such as petrol), newspapers and similar articles must be kept well away from the water heater and the flue terminal.
- Do not use **aerosols, stain removers and household chemicals** near the water heater whilst it is working. Gases from some aerosol sprays, stain removers and household chemicals become corrosive when drawn into a flame.
- Do not store **swimming pool chemicals, household cleaners, etc.**, near the water heater.
- Do not place anything on top of the water heater or in contact with the flue terminal. Ensure the flue terminal is not obstructed in any way at any time.



- Do not use Propane / Butane gas mixtures in a Propane model. A Propane model is designed to operate on Propane only. The use of Propane / Butane mixture, such as automotive LPG fuel, in a Propane model is unsafe and can cause damage to the water heater.

PRECAUTIONS

Where damage to property can occur in the event of the water heater leaking, the water heater must be installed in a safe tray. Construction, installation and draining of a safe tray must comply with AS/NZS 3500.4 and all local codes and regulatory authority requirements.

The water heater must be maintained in accordance with the Owner's Guide and Installation Instructions. Refer to "[General Maintenance](#)" on [page 10](#), "[Minor Six Month Maintenance](#)" on [page 10](#) and "[Annual Service](#)" on [page 11](#).

If this water heater is to be used where an uninterrupted hot water supply is necessary for your application or business you should ensure that you have redundancy within the hot water system design. This should ensure the continuity of hot water supply in the event that this water heater was to become inoperable for any reason. We recommend you seek advice from your plumber or specifier about your needs and building redundancy into your hot water supply system.

GENERAL MAINTENANCE

The jacket of the water heater and controller can be cleaned with a soft cloth and warm mild soapy water. Under no circumstances should abrasive materials or powders be used.

The area around the water heater can be sprayed with insecticide to rid the area of insects. Insects encroaching into or nesting in the water heater can interfere with the operation of the water heater and also damage components.

The minor maintenance includes:

Inspect around the air inlet, flue terminal and the water heater in general for plant growth.

- Trim back any shrubs, bushes or other plants which have encroached around the water heater.
- Plant growth across the air let and flue terminal can interfere with the performance of the water heater.
- Inspect around the water heater for insect infestations, such as ants.
- Spray insecticide around the water heater if necessary to rid the area of insects. Do not spray the surface or into the air inlet or flue terminal of the water heater.
- Insects encroaching into or nesting in the water heater can interfere with the operation of the water heater and also damage components.
- Check the drain line from the safe tray (if one is installed) is not blocked.
- Check and clean filter on CFWH cold water inlet and line strainer.
- For indoor models, check the condensate drain trap is charged with water.

MINOR SIX MONTH MAINTENANCE

It is recommended minor maintenance be performed every six months by the responsible officer.

The minor maintenance includes:

Inspect around the air inlet, flue terminal and the water heater in general for plant growth.

- Trim back any shrubs, bushes or other plants which have encroached around the water heater.
 - Plant growth across the air let and flue terminal can interfere with the performance of the water heater.
- Inspect around the water heater for insect infestations, such as ants.
- Spray insecticide around the water heater if necessary to rid the area of insects. Do not spray the surface or into the air inlet or flue terminal of the water heater.

Insects encroaching into or nesting in the water heater can interfere with the operation of the water heater and also damage components.

- Check the drain line from the safe tray (if one is installed) is not blocked.
- Check and clean filter on CFWH cold water inlet and line strainer.

- For indoor models, check the condensate drain trap is charged with water.
- Operate the easing lever on the temperature pressure relief valve on the storage tank. It is very important you raise and lower the lever gently. Refer to Rheem Storage Tank Owners Guide and Installation Instructions.

ANNUAL SERVICE

For safe and efficient operation, it is recommended an annual service be conducted on the water heater. Only genuine replacement parts should be used on this water heater.



Warning: Servicing of a water heater must only be carried out by qualified personnel. Phone Rheem Service or their nearest Accredited Service Agent.

The annual service includes the following actions:

- Check and if necessary adjust the gas pressure.
- Check the operation of and clean the burner.
- Visually check the unit for any potential problems.
- Inspect all connections.
- Check the drain line from the safe tray (if one is installed) is not blocked.
- Check and clean line strainers on the cold water inlet.
- Check and clean line strainers on the building return line (if installed).
- Check and clean filter on CFWH cold water inlet.
- For indoor models, check the condensate drain trap is charged with water.

TO TURN OFF THE WATER HEATER

If it is necessary to turn off the water heater on completion of the installation, such as on a building site or where the premises are vacant, then:

- Switch off the electrical supply at the isolating switch to the junction box (refer to note below).
- Close the gas isolation valve at the inlet to the Tankpak.
- Close the cold water and hot water flow isolation valves at the inlet and outlet of the Tankpak
- Close the isolation valves on the inlet and outlet at the storage tank(s).
- Drain each CFWH if there is a risk of freezing conditions occurring (refer to [“Draining The Water Heater”](#) on [page 12](#)).

Note: If there is a risk of freezing conditions, the electrical supply to the water heater should not be switched off unless the water heater is drained, otherwise damage could result (refer to [“Frost Protection”](#) on [page 12](#) and [“Draining the Water Heater”](#) on [page 12](#)).

TO TURN ON THE WATER HEATER

- Screw in the drain plugs at the cold water inlet and hot water outlet of the CFWH if they have been drained.
- Open all of the hot taps (don't forget the shower).
- Open the cold water and hot water isolation valve fully at the inlet and outlet to the water heater.
- Open the isolation valves on the storage tanks.

Air will be forced out of the taps.

- Close each tap as water flows freely from it.
- Open the gas isolation valve fully at the inlet to the water heater.
- Switch on the electrical supply to the junction box.
- Switch on the power at the circuit breaker on the Tankpak controller.
- The water heater will operate automatically, after a period of 1 minute following initialisation.

FROST PROTECTION

The water heater has a frost protection system. The frost protection system will protect the water heater from damage, by preventing ice forming in the waterways of the water heater, in the event of freezing conditions occurring.

Notes:

- The frost protection system will be rendered inoperable if electrical power is not available at the water heater. Damage caused by freezing due to the unavailability of power at the water heater is not covered by the Rheem warranty (refer to “[Terms of the Rheem Warranty](#)” on [page 5](#)).
- If it is necessary to switch the power off to the water heater and there is a risk of freezing, then it is necessary to drain the water heater (refer to “[Draining the Water Heater](#)” on [page 12](#)).
- The water heater is not suitable for installation in areas where the ambient temperature falls below -20°C (including wind chill factor). Refer to “[Terms of the Rheem Warranty](#)” on [page 5](#).

DRAINING THE WATER HEATER

To drain the water heater:

- Turn off the water heater (refer to “[Turn Off The Water Heater](#)” on [page 11](#)).
- Unscrew the two drain plugs, one each at the cold water inlet and hot water outlet, on the underside of each continuous flow water heater.

Water will drain from the water heaters.

Note: It is recommended not to screw the drain plugs back in, until the water heater is to be turned on again.

TO DRAIN THE STORAGE TANK:

- Close isolation valve on inlet and outlet of storage tank.
- Operate the relief valve release lever - do not let the lever snap back or you will damage the valve seat.
- Operating the lever will release the pressure in the storage tank.
- Undo the union at the cold water inlet to the storage tank and attach a hose to the storage tank side of the union.
- Let the other end of the hose go to a drain.
- Operate the relief valve again.
- This will let air into the storage tank and allow the water to drain through the hose.

HOW DO I KNOW IF THE WATER HEATER IS INSTALLED CORRECTLY?

Installation requirements are shown on pages [26 to 63](#). The water heater must be installed:

- by a qualified person, and
- in accordance with the installation instructions, and
- in compliance with Standards AS/NZS 3500.4, AS 3000, AS/NZS 5601.1, and all local codes and regulatory authority requirements.

DOES THE WATER CHEMISTRY AFFECT THE WATER HEATER?

The water heater is suitable for most public water supplies, however some water chemistries may have detrimental effects on the water heater, its components and fittings. Refer to “[Water Supplies](#)” on [page 13](#).

If you are in a known harsh water area or you are not sure of your water chemistry, have your water checked against the conditions described on [page 13](#).

HOW LONG WILL THE WATER HEATER LAST?

The water heater is supported by a manufacturer’s warranty (refer to [page 4](#)). There are a number of factors that will affect the length of service the water heater will provide. These include but are not limited to the water chemistry, the water pressure, the water temperature (inlet and outlet) and the water usage pattern. Refer to “[Precautions](#)” on [page 10](#).

WATER SUPPLIES

This water heater must be installed in accordance with this advice to be covered by the Rheem warranty.

This water heater is manufactured to suit the water conditions of most public reticulated water supplies. However, there are some known water chemistries which can have detrimental effects on the water heater and its operation and / or life expectancy. If you are unsure of your water chemistry, you may be able to obtain information from your local water supply authority. This water heater should only be connected to a water supply which complies with these guidelines for the Rheem warranty to apply.

CHANGE OF WATER SUPPLY

The changing or alternating from one water supply to another can have a detrimental effect on the operation and / or life expectation of a heat exchanger in a continuous flow water heater and a temperature pressure relief valve in a storage tank cylinder.

Where there is a changeover from one water supply to another, e.g., a rainwater tank supply, bore water supply, desalinated water supply, public reticulated water supply or water brought in from another supply, then water chemistry information should be sought from the supplier or it should be tested to ensure the water supply meets the requirements given in these guidelines for the Rheem warranty to apply.

SATURATION INDEX

The saturation index (SI) is used as a measure of the water's corrosive or scaling properties.

In a corrosive water supply, the water can attack copper parts and cause them to fail. Where the saturation index is less than -1.0 , the water is very corrosive and the Rheem warranty does not apply to a copper heat exchanger in a continuous flow water heater or the copper pipe work in the Tankpak assembly.

In a scaling water supply calcium carbonate is deposited out of the water onto any hot metallic surface. Where the saturation index exceeds $+0.40$, the water is very scaling. An expansion control valve must be fitted on the cold water line after the non-return valve to protect and for the Rheem warranty to apply to the temperature pressure relief valve and storage tank cylinder.

Where the saturation index exceeds $+0.80$, the Rheem warranty does not apply to a copper heat exchanger in a continuous flow water heater or the copper pipe work in the Tankpak assembly.

Water which is scaling may be treated with a water softening device to reduce the saturation index of the water.

Refer to the [Saturation Index chart](#) on [page 13](#).

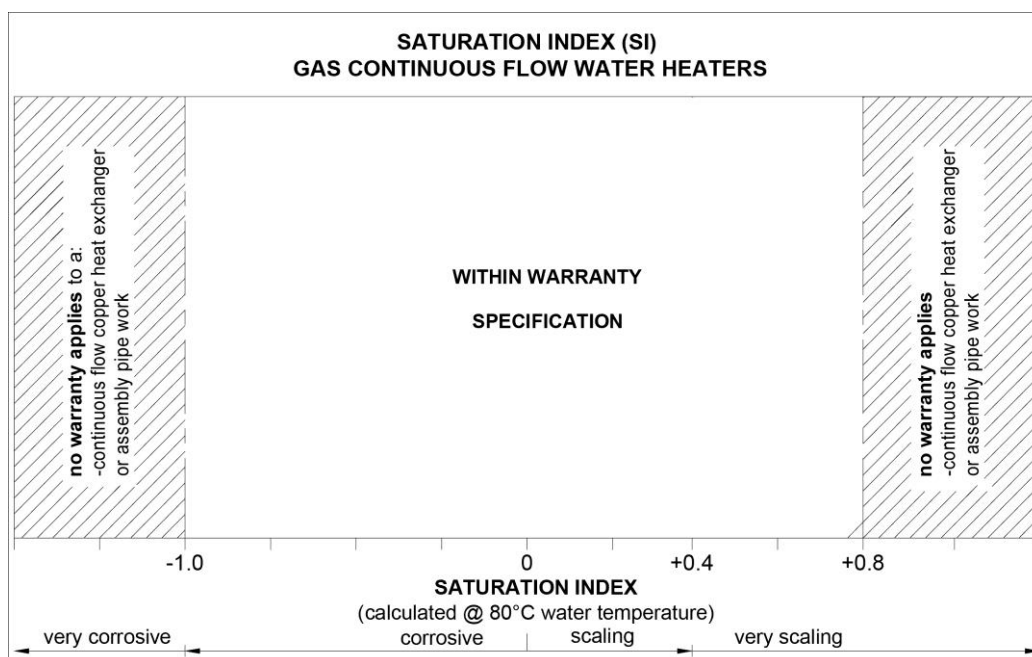

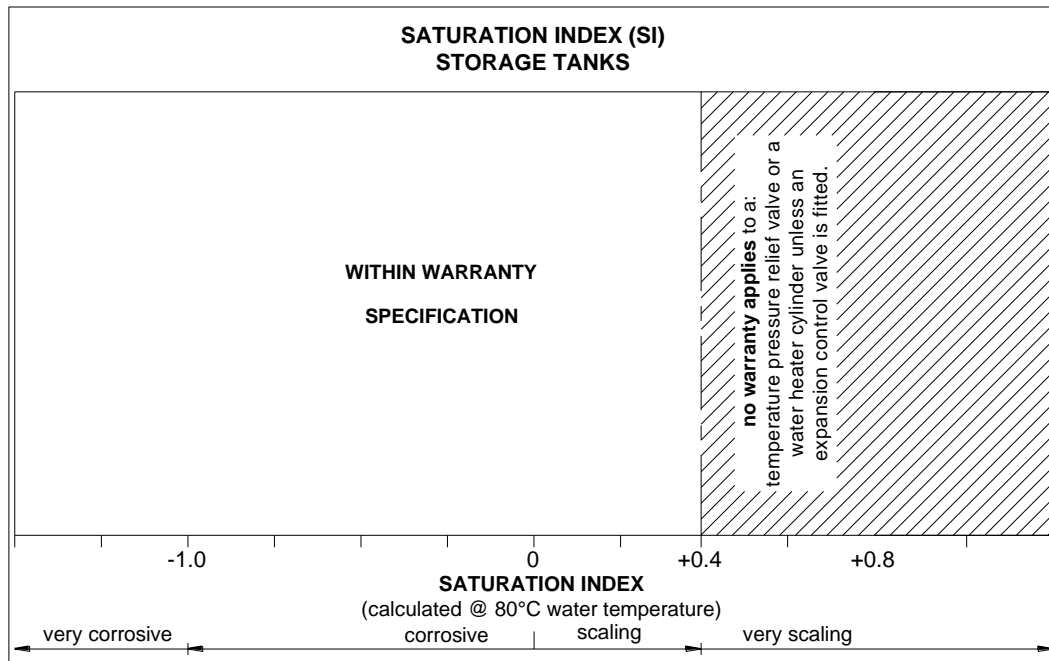

ANODE

The vitreous enamel lined cylinder of the storage tank is only covered by the Rheem warranty when the total dissolved solids (TDS) content in the water is less than 2500 mg/L and when the correct colour coded anode is used. If an incorrect colour coded anode is used in the storage tank, any resultant faults will not be covered by the Rheem warranty. In addition, the use of an incorrect colour coded anode may shorten the life of the storage tank cylinder.

The correct colour coded anode must be selected and fitted to the storage tank in accordance with the following advice and the [Anode Selection chart](#) on [page 14](#) for the Rheem warranty to apply to the storage tank cylinder.

Total Dissolved Solids	Anode colour code
0 – 40 mg/L	Green
40 – 150 mg/L	Green or Black
150 – 400 mg/L	Black
400 – 600 mg/L	Black or Blue
600 – 2500 mg/L	Blue
2500 mg/L +	Blue (no cylinder warranty)

The changing of an anode must be carried out by a qualified person.

Note: Some water analysis reports may state the conductivity of the water rather than the level of total dissolved solids. Conductivity, measured in microsiemens per centimetre ($\mu\text{S} / \text{cm}$), is directly proportional to the TDS content of the water. TDS, in mg / L , is approximately 70% of the conductivity in $\mu\text{S} / \text{cm}$.

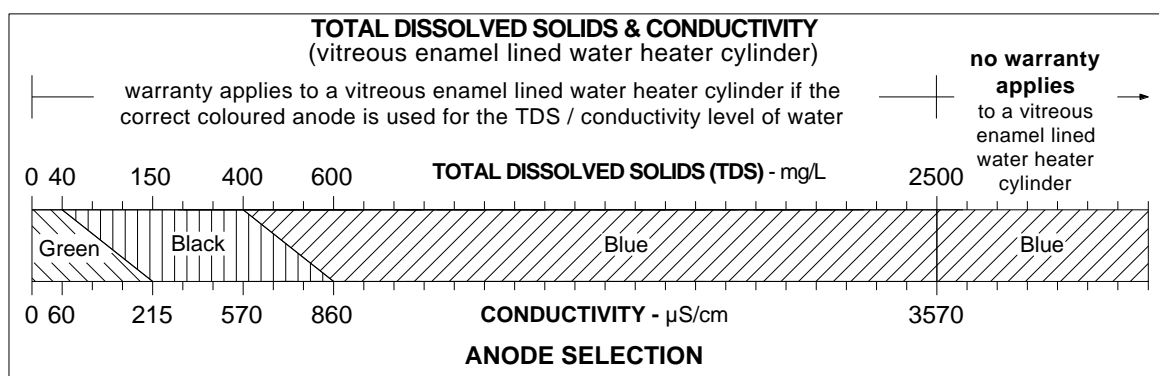

CHLORIDE AND PH

Where the chloride level exceeds 250 mg/L the Rheem warranty does not apply to the water heater. In a high chloride water supply, the water can corrode stainless steel parts and cause them to fail.

Where the pH is less than 6.0 the Rheem warranty does not apply to the pump of the Tankpak water heater. pH is a measure of whether the water is alkaline or acid. In an acidic water supply, the water can attack stainless steel parts and cause them to fail.

Water with a pH less than 6.0 may be treated to raise the pH. The water supply from a rainwater tank in a metropolitan area is likely to be corrosive due to the dissolution of atmospheric contaminants.

SUMMARY OF WATER CHEMISTRY ADVICE AFFECTING WARRANTY

The water heater storage tank and its components (the system) are not suitable for certain water chemistries. Those chemistries are listed below. If the system is connected at any time to a water supply with the following water chemistry, the Rheem warranty will not cover any resultant faults on the components listed below:

Water Chemistry	Component
Total Dissolved Solids (TDS) > 2500 mg/L	storage tank cylinder
Total Dissolved Solids (TDS) not suitable for anode type	storage tank cylinder
Saturation Index (SI) < -1.0	water heater
Saturation Index (SI) > +0.4 (if an expansion control valve is not fitted)	storage tank cylinder, temperature pressure relief valve
Saturation Index (SI) > +0.8	water heater
Chloride > 250 mg/L	water heater
pH < 6.0	water heater

SAVE A SERVICE CALL

Check the items below before making a service call. You will be charged for attending to any condition or fault, which is not related to manufacture or failure of a part (refer to “[Terms of the Rheem Warranty](#)” on [page 5](#)).

COLD WATER FROM THE HOT TAP

- Allow 15 minutes from start up to ensure an uninterrupted supply of hot water.
- Is the building return circulator turned on and operating? Note: In a Tankpak Deluxe model supplied with factory fitted building circulators, the initialisation process locks out the building circulators until the tank is 4°C below set point to allow for faster commissioning.
- In a circulatory building flow and return circuit, balancing valves may be installed. Incorrectly set balancing valves may mean it takes longer for hot water to be delivered to the taps.

Refer to your plumber.

- Is the Tankpak wired to a power supply and the isolating switch turned on?
- Are the CFWHs plugged in and the power outlet switched on?
- Is the circuit breaker in the Tankpak controller switched on?
- Are the cold water inlet filters clear?
- Is power available in the premises?
Try using another electrical appliance.
- Is the isolation valve in the gas line open?
- Is there a gas supply to the rest of the premises?
Try lighting another gas appliance.
- Has the gas line been purged of air after installation?

Refer to your plumber.

WATER IS TOO HOT OR NOT HOT ENOUGH

- Is the preset outlet temperature of the water heater higher or lower than required?

NO WATER FROM THE HOT TAP

No flow of water from the hot tap may indicate a restriction in or failure of the cold water supply to the water heater. Check for water flow at other taps and that the cold water isolation valve is fully open.

WATER TEMPERATURE FLUCTUATES

This can be evident if the water heater has been installed as an in-series gas booster to a solar water heater. Also, under certain flow conditions water will be delivered preferentially from the storage tank or continuous flow water heaters. A slight variation in temperature may be sensed.

FAN CONTINUES TO RUN AFTER WATER HEATER OPERATION STOPS

It is the normal operation of the water heater for the fan to continue running after heating of the water is finished. The fan may run for up to six minutes after the burners extinguish, to prepare for the next ignition.

CLOUDS OF WHITE ‘VAPOUR’ FROM THE FLUE TERMINAL

During the heating cycle, it is not unusual to see water vapour clouds steaming from the flue terminal, particularly on cold days. This is normal operation of the water heater.

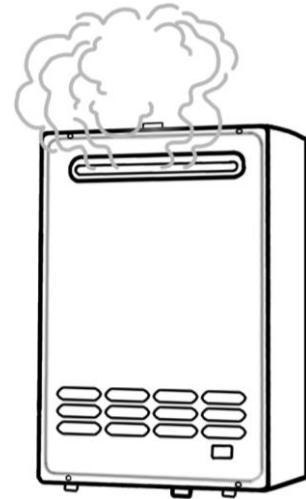

PRESSURE RELIEF VALVE DISCHARGING

A pressure relief valve is incorporated into the continuous flow water heater controls. This valve protects the water heater, by allowing water to escape, in the event of excessive pressure build up in the waterways.

- **Normal operation**
A small volume of water may discharge from the bottom of the water heater when a hot tap is suddenly closed.
- **Continuous dribble**
A continuous dribble may indicate the water supply pressure is above the design pressure for the water heater. If so, a pressure limiting valve must be installed on the cold water supply pipe to the water heater (refer to “Mains Water Supply” on [page 38](#)).

Refer to Owners Guide and Installation instructions of the storage tank for issues relating to Temperature & Pressure Relief Valve and Expansion Control valve.

ERROR CODE FOR CONTINUOUS FLOW WATER HEATER UNIT

The water heater provides a diagnostic error code in the event of an interruption to its operation. The error code is displayed on the OK MONITOR on the front of the water heater as a numerical value. In a Tankpak Deluxe model, the error code is also displayed on the controller display. If an error code appears:

- The Tankpak Series 3 controller will automatically close off the water supply to a CFWH that is in error and move to the next available CFWH.
- Check the gas isolation valve at the gas inlet to the water heater is fully open.
- A water heater in error will not be re-instated until the next call for heat cycle.
- Depending on the staging sequence, the water heater may not be brought on line. Increase demand by opening more hot taps to force the Tankpak into maximum fire condition.



If the error code persists, take note of the numerical code, turn off the isolating valve on the hot outlet of the water heater in question. Phone Rheem Service or their nearest Accredited Service Agent to arrange for inspection.

ERROR CODE FOR STANDARD CONTROLLER

The ERROR LED (RED) will flash if there is an error. Refer to the table below for details:

Error Type	RED LED Flash times	Diagnostic
CFWH	1	Refer to Error Code for CFWH Unit
Blocked CFWH filter	2	Remove and clean filters
Water Flow Sensor	3	Refer to Rheem Service
Smartec Interface	4	Check Smartec Cable
Temperature sensor	5	Check PT1000 Cable and Sensor.
Pump Failure	6	Check Pump and Cable
12V DC Power Supply failure	7	Check Power Supply
Tank Sensor not inserted correctly in thermowell	8	Check Sensor position (and insert it fully in the thermowell).

ERROR CODE FOR DELUXE CONTROLLER

Deluxe Controller Display	Error	Cause of Error	Diagnostic
HXX ErrCode = 5 to 99, Error Description	CFGWH error	various	Refer to Rheem Service
e.g. HXX ErrCode = 11, Ignition Fail	CFGWH number Ignition failure	Insufficient gas supply pressure	Check gas pressure and purge lines
e.g. HXX ErrCode = 12, Flame Fail	CHGWH number Loss of flame	Insufficient gas supply pressure	Check gas pressure and purge lines
e.g. HXX ErrCode = 21, Restrictor BLK	CFGWH number Inlet Filter Blockage	Insufficient or no water flow	Check water supply and clean inlet filter on indicated CFGWH
ErrCode = 111, HXX Smartec Comms	Smartec interface	Lost communication with CFGWH	Check Smartec Cable on indicated CFWH
ErrCode = 112, CEM XX Modbus RS485	Modbus RS485	Lost communication with CEM	Check RS485 Cable and CEM
ErrCode = 121, Tank Sensor	Tank Bottom Temperature Sensor	Sensor cable open circuit or short circuit	Check PT1000 cable and sensor
ErrCode = 122, Bldg Rtn Sensor	Building Return Temperature Sensor	Sensor cable open circuit or short circuit	Check PT1000 cable and sensor
ErrCode = 123, Bldg Flo Sensor	Building Flow Temperature Sensor	Sensor cable open circuit or short circuit	Check PT1000 cable and sensor
ErrCode = 124, Tank Sensr OnAir	Tank Bottom Temperature Sensor	Tank Sensor not fully inserted into the sensor well	Check Sensor position (and insert it fully in the thermowell).
ErrCode = 131, PP1 No Flow	Primary Pump1	Faulty pump or cable	Check pump and cable
ErrCode = 132, PP2 No Flow	Primary Pump2	Faulty pump or cable	Check pump and cable
ErrCode = 133, SP1 No Flow	Secondary Pump1	Faulty pump or cable	Check pump and cable
ErrCode = 134, SP2 No Flow	Secondary Pump2	Faulty pump or cable	Check pump and cable

IF YOU HAVE CHECKED ALL THE FOREGOING AND STILL BELIEVE YOU NEED ASSISTANCE, phone Rheem Service or their nearest Accredited Service Agent.

TANKPAK SERIES 3 – TECHNICAL SPECIFICATIONS

TANKPAK MODEL NUMBERS

Tankpak Series 3 systems are assigned with 14 digit model numbers. The description of digits as shown below.

T P 3 E 0 4 N F D 2 1 8 2 4

														__Secondary pump model: 0=no pump; 1=CM3-2; 4=UPM 3 25-70; 5=UPM XL 25-125
														__Secondary pump quantity: 0 = no pump; 2=2 pump
														__Water heater identifier
														__Primary pump model: 1=CM3-2; 2=CM5-2; 3=CM10-1
														__Primary pump quantity; 1=1 pump; 2=2 pump
														__Controller type: S=Standard; D=Deluxe
														__Frame configuration: F=Floor mount; W=Wall mount; B=Back to Back
														__CFWH gas type: N=Natural gas; P=Propane; L=ULPG
														__Number of CFWHs
														__CFWH type: E=External; I=Internal
														__Series 3
														__Country: P=Australia; Z=New Zealand
														__Tankpak

TANKPAK SERIES 3 PACKAGE IS COMPRISED OF:

RHEEM WATER HEATERS

- Two (2) to eighteen (18) Rheem Continuous Flow Water Heaters (CFWH)
- Mounted and plumbed in parallel on a galvanised steel frame
- 2-9 may be wall mounted or floor mounted inline
- 4-18 may be floor mounted back to back

PLUMBING DETAILS

- Cold water inlet and hot water outlet piping, valves and fittings to AS3500.4. All plumbing components are WaterMark certified
- Line strainer fitted to inlet of primary pump
- Building return circulator pumps, piping, valves and fittings (model dependant)
- Gas piping and fittings to AS/NZS5601.1
- Insulation- foil faced closed cell on hot and cold manifolds

ELECTRICAL DETAILS

- 10-30 AMP 240V AC 50Hz single phase power supply required to package (model dependant)
- Standard or Deluxe controller and controller extension modules (model dependant)
- Electrical junction box
- GPO's encased in water-proof enclosure
- Pumps wired to controller except CM3-2 remote secondary pumps to be hard wired to controller with Deluxe models
- 10 amp plug and lead supplied on systems with Standard controller and systems with Deluxe controller up to 4 CFWHs with UPM 3 or UPM XL secondary pumps. All other systems must be hardwired by a suitably qualified person

ELECTRICAL DETAILS – SECONDARY PUMPS

Pump Models	Rated Voltage	Max Current per Pump
UPM 3 25-70 N	230V 50/60Hz	0.52 A
UPM XL 25-125 N	230V 50/60Hz	1.42 A
CM3-2	220-240V 50/60Hz	1.80-2.4 A

Model ⁵	No of Units	Thermal Input (MJ / h)	Recommended Storage Model ²	Recovery @ 50°C rise (L/hr)	First Hour Capacity (L) ⁴	Mounting Options	Width (mm) Wall and Floor / Back to Back	Height	Weight (kg) Wall and Floor / Back to Back ¹	Primary Flow and Return Pipe SizeP (mm)	Primary Pump Model	Max Water supply Pressure ⁴ with ECV / without ECV (kPa)	Gas Pipe Conn (mm) In Line / Back to Back	Electrical Supply (240V/1Ph/50Hz) Max Current Running (Amps) ⁶
TP3E02/TP3I02	2	410	610340/610430	1645	1970/2055	W/F	755	1683	251	25	CM 3-2	680/800	40 / -	5.1
TP3E03/TP3I03	3	615	610340/610430	2470	2795/2880	W/F	1118	1683	288	32	CM 3-2	680/800	40 / -	5.9
TP3E04/TP3I04	4	820	610340/610430	3290	3615/3700	W/F/B	1481/755	1683	326 / 306	40	CM 3-2	680/800	40 / 40	6.7
TP3E05/TP3I05	5	1025	1 x 610430	4115	4525	W/F/B	1844/1118	1683	390 / 346	40	CM 5-2	680/800	50 / 40	7.9
TP3E06/TP3I06	6	1230	1 x 610430	4935	5345	W/F/B	2207/1118	1683	427 / 370	40	CM 5-2	680/800	50 / 40	8.8
¹ includes 410L tank per column 4. internal model shown. subtract 3kg per CFWH for external model ² tank capacity 610340 is 325L, 610430 is 410L ⁴ Rheem 610 series storage tanks. ECV not supplied with water heater ⁵ includes TP models for Australia and equivalent TZ models for New Zealand ⁶ supplied with 1.8m 10Amp plug and lead														

Technical Specifications Table: Standard models

Model ⁵	No of Units	Thermal Input (MJ / h)	Recommended Storage Model ²	Recovery @ 50°C rise (L/hr)	First Hour Capacity (L) ⁴	Mounting Options	Width ⁶ (mm) Wall and Floor / Back to Back	Height	Weight (kg) Wall and Floor / Back to Back ¹	Primary Flow and Return Pipe Size (mm)	Primary Pump Model	Max Water supply Pressure ⁴ with ECV / without ECV (kPa)	Gas Pipe Conn (mm) In Line / Back to Back	Electrical Supply (240V/1Ph/50Hz) Max Current Running ³ (Amps)
TP3E02/TP3I02	2	410	610340/610430	1645	1970/2055	W/F	755	1683	305	25	CM 3-2	680/800	40 / -	7.5 ⁷
TP3E03/TP3I03	3	615	610340/610430	2470	2795/2880	W/F	1118	1683	342	32	CM 3-2	680/800	40 / -	8.3 ⁷
TP3E04/TP3I04	4	820	610340/610430	3290	3615/3700	W/F/B	1481/755	1683	380 / 360	40	CM 3-2	680/800	40 / 40	9.2 ⁷
TP3E05/TP3I05	5	1025	1 x 610430	4115	4525	W/F/B	1844/1118	1683	444 / 400	40	CM 5-2	680/800	50 / 40	10.7
TP3E06/TP3I06	6	1230	1 x 610430	4935	5345	W/F/B	2207/1118	1683	481 / 424	40	CM 5-2	680/800	50 / 40	11.5
TP3E07/TP3I07	7	1435	1 x 610430	5760	6170	W/F/B	2570/1481	1683	527 / 476	50	CM 5-2	680/800	50 / 50	12.4
TP3E08/TP3I08	8	1640	2 x 610430	6580	7400	W/F/B	2933/1481	1683	702 / 633	50	CM10-1	680/800	50 / 50	14.5
TP3E09/TP3I09	9	1845	2 x 610430	7405	8225	W/F/B	3296/1844	1683	766 / 701	50	CM10-1	680/800	50 / 65	15.3
TP3E10/TP3I10	10	2050	2 x 610430	8225	9045	B	1844	1683	725	50	CM10-1	680/800	- / 65	16.1
TP3E12/TP3I12	12	2460	2 x 610430	9875	10695	B	2207	1683	907	50	CM10-1	680/800	- / 65	17.8
TP3E14/TP3I14	14	2870	3 x 610430	11520	12750	B	2570	1683	981	65	CM10-1	680/800	- / 65	19.5
TP3E16/TP3I16	16	3280	3 x 610430	13165	14395	B	2933	1683	1047	65	CM10-1	680/800	- / 80	21.1
TP3E18/TP3I18	18	3690	3 x 610430	14810	16040	B	3296	1683	1143	65	CM10-1	680/800	- / 80	22.7

¹ includes 410L tank/s per column 4. internal model shown. subtract 3kg per CFWH for external model

² tank capacity 610340 is 325L, 610430 is 410L
³ Based on all heaters, 1x primary pump and 2x UPMXL operating simultaneously

⁴ Rheem 610 series storage tanks
⁵ includes TP models for Australia and equivalent TZ models for New Zealand

⁶ Width excludes UPM secondary pumps mounted on frame. Add 265mm for UPM secondary pump mounted on frame
⁷ supplied with 1.8m 10A plug and lead up to UPM XL secondary circulators

Technical Specifications Table: Deluxe models with duty/standby primary pumps and duty/standby UPMXL secondary pumps

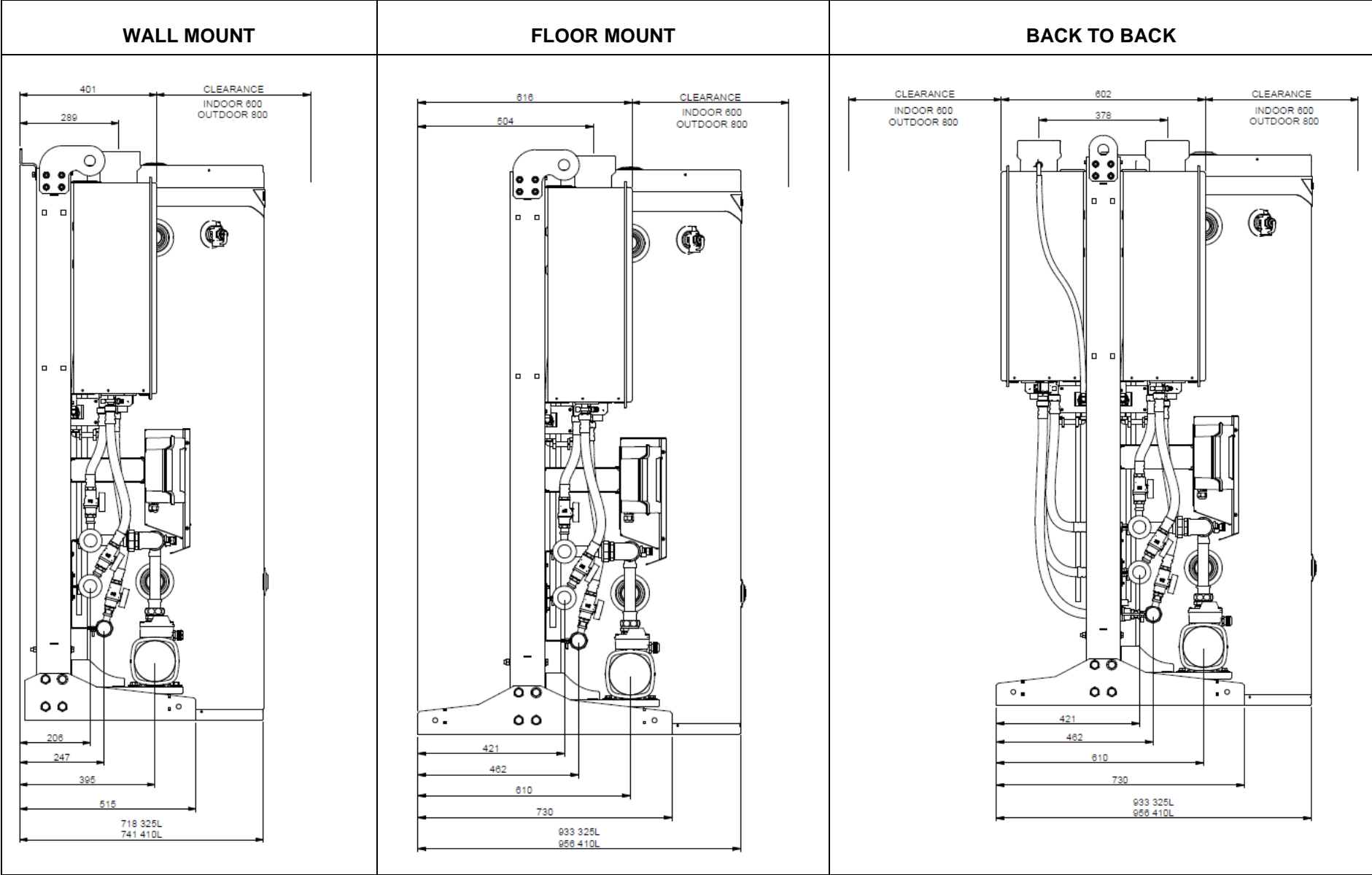

FIGURE 1: TANKPAK SERIES 3 STANDARD CONTROLLER MODELS - DEPTH

ALL DIMENSIONS ARE REFERENCE ONLY

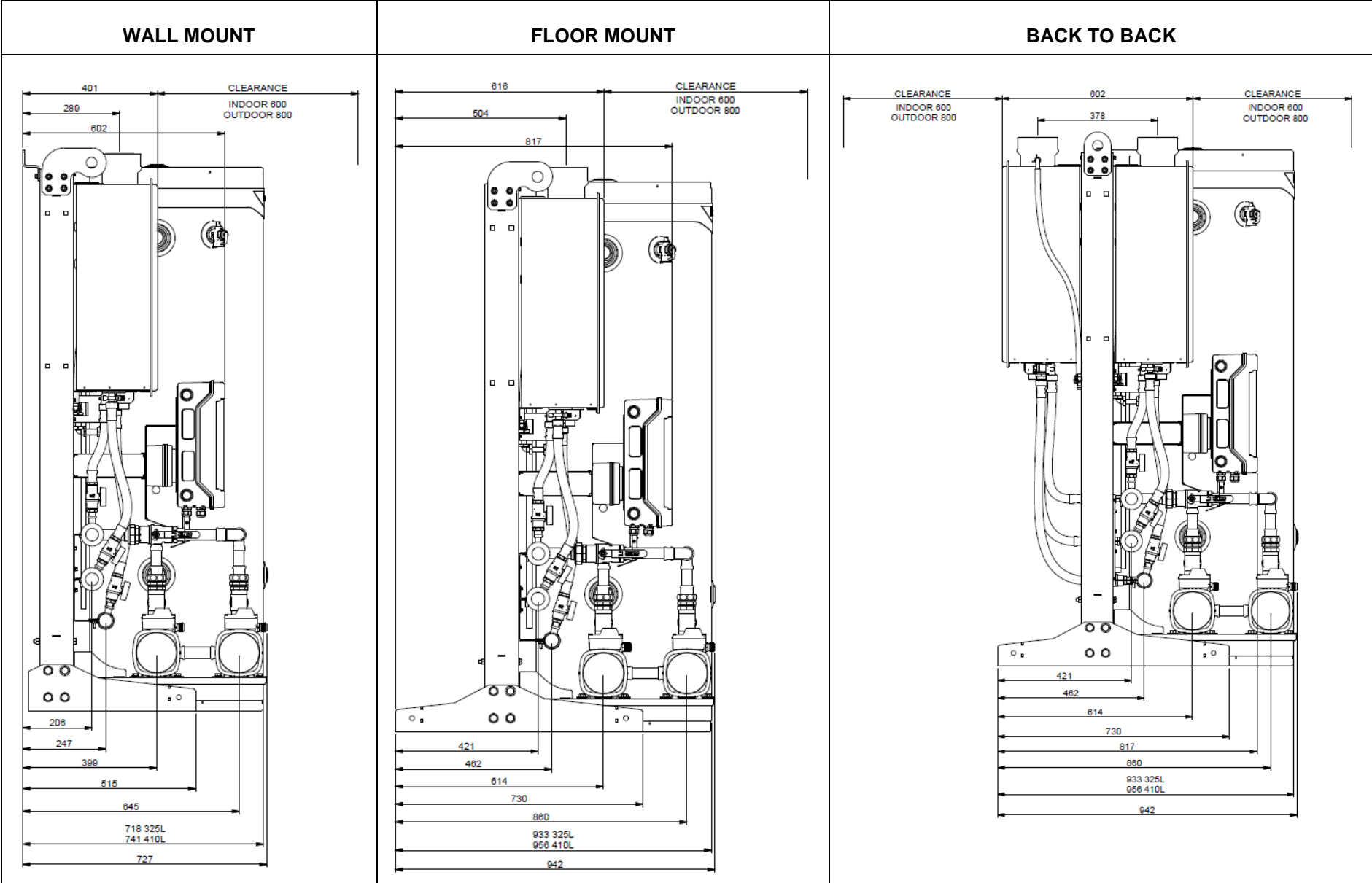
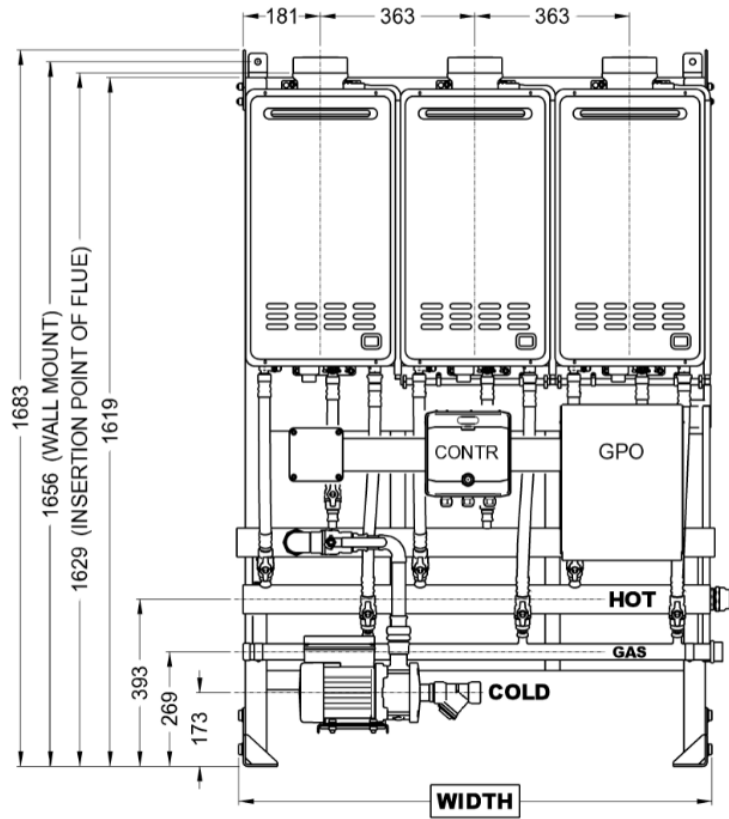

FIGURE 2: TANKPAK SERIES 3 DELUXE CONTROLLER MODELS WITH DUTY/STANDBY PRIMARY PUMPS - DEPTH

ALL DIMENSIONS ARE REFERENCE ONLY

WIDTH	No OF HEATERS	Standard & Deluxe Controller					Deluxe Controller Only							
		2	3	4	5	6	7	8	9	10	12	14	16	18
	Inline (mm)	755	1118	1481	1844	2207	2570	2933	3296	-	-	-	-	-
	Back to Back (mm)	-	-	755	1118	1118	1481	1481	1844	1844	2207	2570	2933	3296

ALL DIMENSIONS ARE REFERENCE ONLY



STANDARD CONTROLLER

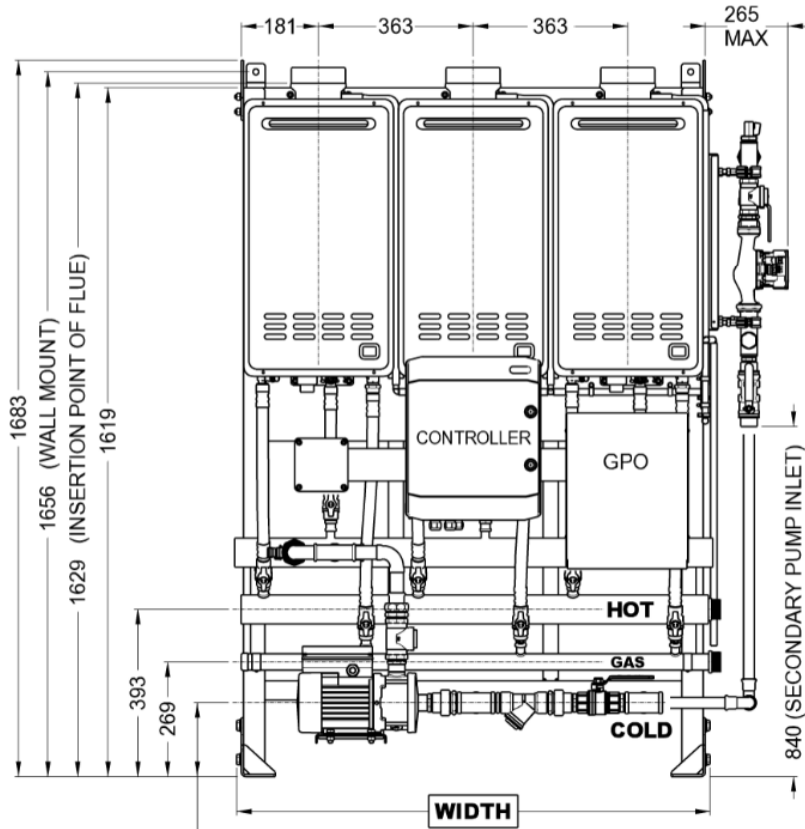

173 (FOR ≤ 7 HEATERS)
198 (FOR ≥ 8 HEATERS) **DELUXE CONTROLLER WITH SECONDARY PUMPS**

FIGURE 3: TANKPAK SERIES 3 STANDARD AND DELUXE - FRONT ELEVATION

INSTALLATION – WATER HEATER

THIS WATER HEATER IS FOR OUTDOOR OR INDOOR INSTALLATION, MODEL DEPENDANT.

THIS WATER HEATER IS NOT SUITABLE FOR POOL HEATING.

Check the water heater is suitable for the gas type available.

(refer to the rating label on the water heater)

INSTALLATION STANDARDS

This water heater must be installed in compliance with the Plumbing Code of Australia (PCA).

Warning: – This water heater may deliver water at high temperature. Refer to the Plumbing Code of Australia, local requirements and these installation instructions to determine if additional delivery temperature control is required.

Warning: – For continued safety of this appliance, it must be installed, operated and maintained in accordance with the manufacturer's instructions.

The water heater must be installed:

- by a qualified person, and
- in accordance with the installation instructions, and
- in compliance with the Plumbing Code of Australia (PCA), Standards AS/NZS 3500.4, AS 3000 and AS/NZS 5601.1 and all local codes and regulatory authority requirements.
- In New Zealand the installation must also conform with NZS 5261, as applicable under local regulations, and the New Zealand Building Code.

All packaging materials must be removed from the water heater prior to its installation.

WATER HEATER APPLICATION

This water heater is designed for the purpose of heating potable water. Its use in an application other than this may shorten its life.

If this water heater is to be used where an uninterrupted hot water supply is necessary for the application or business, then there should be redundancy within the hot water system design. This should ensure the continuity of hot water supply in the event that this water heater was to become inoperable for any reason. We recommend you provide advice to the system owner about their needs and building redundancy into the hot water supply system.

Note: AS 3498 requires that a water heater provides the means to inhibit the growth of Legionella bacteria in potable water. When this water heater is used as an in-series booster for a solar water heater it can satisfy this AS 3498 requirement provided it is energised and the booster preset outlet temperature setting is 70°C or higher.

WATER HEATER LOCATION

The water heater should be installed in a position chosen with safety and service in mind. If this water heater is part of a solar water heater system, it should also be installed close to the solar storage tank. Make sure people (particularly children) will not touch the flue terminal. The flue terminal and air inlet must be clear of obstructions and shrubbery.

Clearance must be allowed for servicing of the water heater. The water heater must be accessible without the use of a ladder or scaffold. Make sure the entire front panel can be removed for service. You must be able to read the information on the rating plate. Remember you may have to remove a water heater later for servicing.

The water heater must be installed vertically upright. Wall mounted versions must be installed on a solid wall capable of supporting the weight of the Tankpak system. Free standing versions can be mounted in any location on a solid base. The frame must be secured to the floor at all anchor points provided, refer to 'OUTDOOR INSTALLATION' on [page 33](#).

The water heater must not be installed in an area with a corrosive atmosphere, where chemicals are stored or where aerosol propellants are released. Remember the air may be safe to breathe, but when it goes through a flame, chemical changes take place which may attack the water heater.

DISASSEMBLY

The Rheem Tankpak Series 3 has been designed to allow on-site disassembly to enable the system to be positioned into otherwise inaccessible locations where it can be re-assembled.

By following these instructions, a suitably qualified tradesperson can proceed and complete the necessary work required. In most cases, electrical trades are not required for this procedure to be carried out.

Disassembly is not covered by the Rheem warranty. Rheem cannot accept any responsibility for the cost of repair or rectification if this procedure has not been followed.

WARNING: To avoid rain ingress via the flue terminals causing potential water damage to internal components, do not leave the CFWH units in an exposed location for any length of time during the disassembly and reassembly procedure.

1. Disconnect continuous flow water heaters (CFWH units) from the cold, hot and gas flexible hose connections.
2. Unplug the power cords from the GPO sockets. Remove the P-clips holding the power cords onto the frame assembly by removing the Tek screws. Carefully cut any cable ties holding the cable in place.
3. Unscrew the four screws retaining the front cover of the CFWH units and carefully disconnect the connector on the PCB as shown in **Figure 4**. Undo the P-clip securing the Smartec cable and remove the cable out of the units through the grommet located on the bottom panel of the units. Affix the front cover back onto the CFWH units. Identify location on the frame from which each Smartec cable was taken.
4. Unscrew the CFWH units from the frame mountings. Three screws at top and two at bottom of CFWH units (refer to **Figure 5**).
5. For systems with UPM 3 or UPM XL secondary pump assembly fitted, loosen two unions to remove the piping running from the outlet of the secondary pump assembly to the cold water supply tee fitting **Figure 6**. Undo the pipe clamps securing the piping. Disconnect the power connector on the pumps and carefully cut any cable ties holding the power cables in place. Disconnect the temperature sensor from the dry thermowell by undoing the cable gland and cut any cable ties holding the sensor cable in place. The secondary pump assembly can now be removed by unscrewing four bolts securing the pump bracket to the frame upright **Figure 6**.
6. For multiple frame systems, remove the GPO assembly and extension module from the frame that does not contain the controller and pump, by removing the four screws for each GPO assembly and extension module. It may not be necessary to disconnect the wiring. Carefully cut the cable ties holding the cable in place and temporarily secure the GPO assembly and extension module onto the frame with the controller. Ensure electrical cables and connections are not stretched or damaged (refer to **Figure 7**).

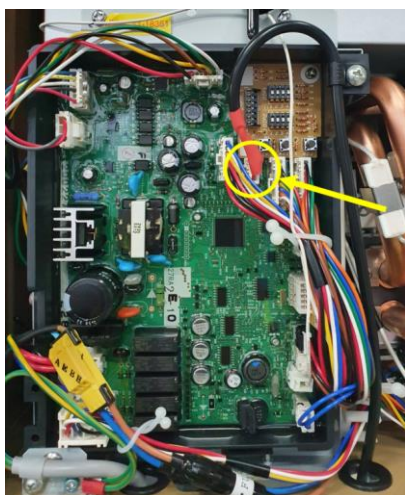

Figure 4

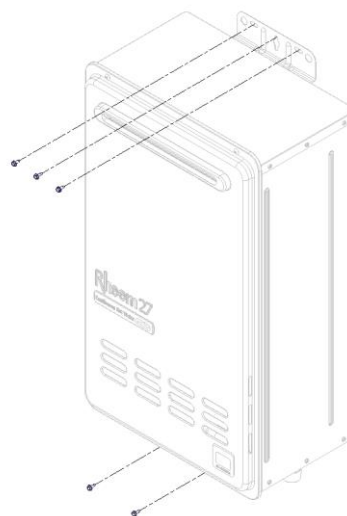

Figure 5

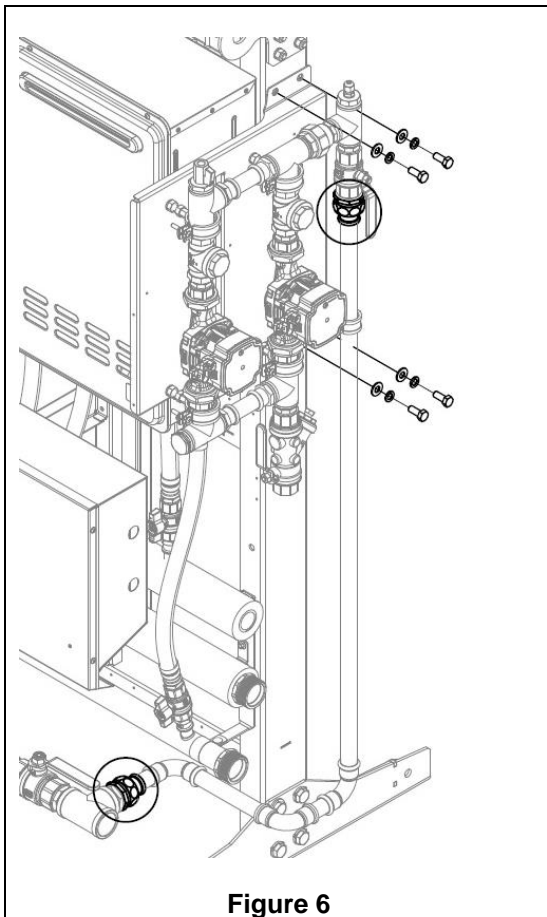

Figure 6

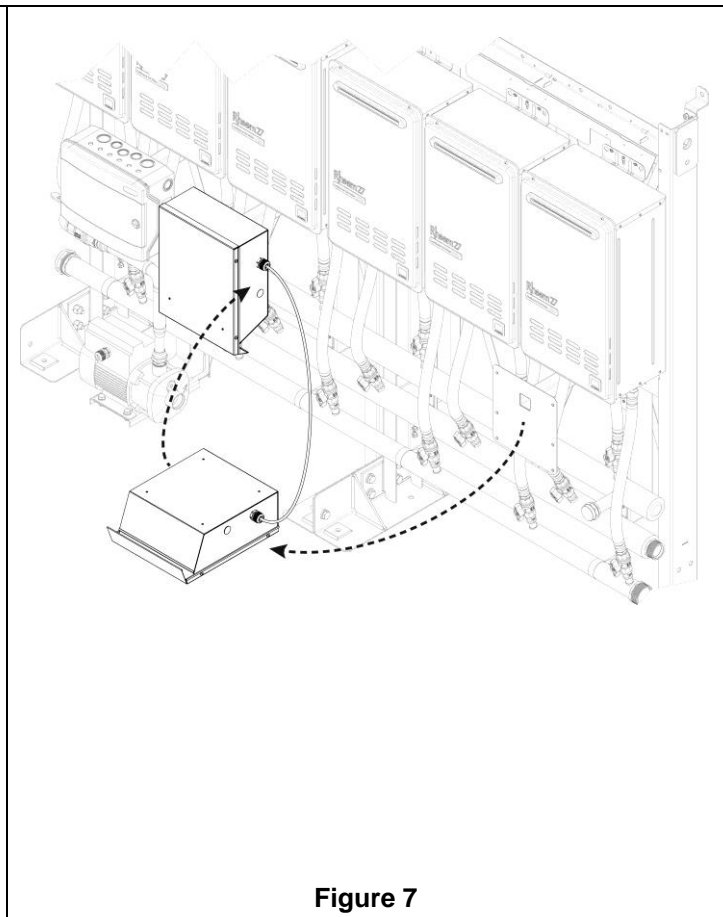

Figure 7

7. Disconnect the pump unions from the cold manifold at the points shown in **Figure 8a** and **Figure 8b** and unbolt the water and gas manifolds from the frame clip head brackets (Note relative positions for reassembly).
8. For indoor systems, if required, remove a condensate drain manifold by carefully cutting the cable ties holding the condensate drain manifold fittings to the condensate drain silicone tube. Disconnect the silicone tubes off the condensate drain manifold fittings. Undo the p-clips securing the condensate drain manifold by unfastening the tek screws, as well as the screws on the p-clips holding the condensate trap assembly. Remove the condensate drain manifold off the frame.
9. If required, remove the pump by first removing the wiring from the pump and unscrewing 4 x bolts holding it to the bracket. A restricted electrical licence (minimum) will be required if the pump is to be disconnected from the frame and later re-assembled. Refer to **Figure 8a** and **8b**.
10. If required, remove the pump bracket by removing 2 x bolts holding it to the frame. Refer to **Figure 9**.

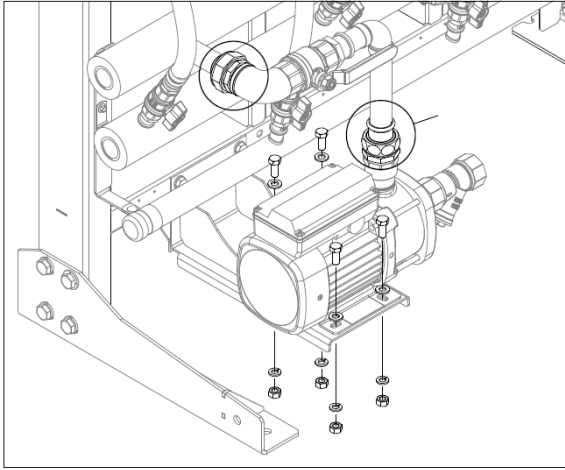

Figure 8a

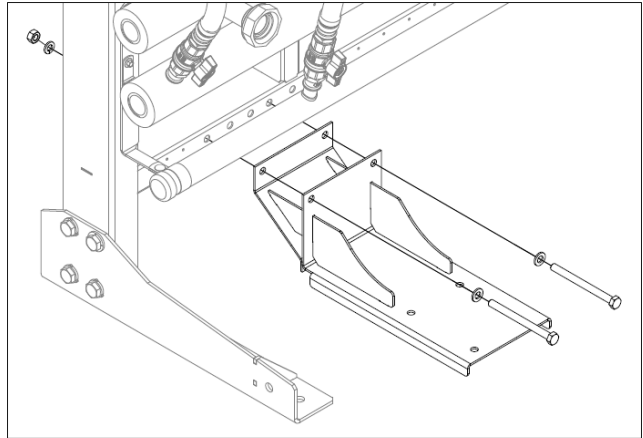

Figure 9

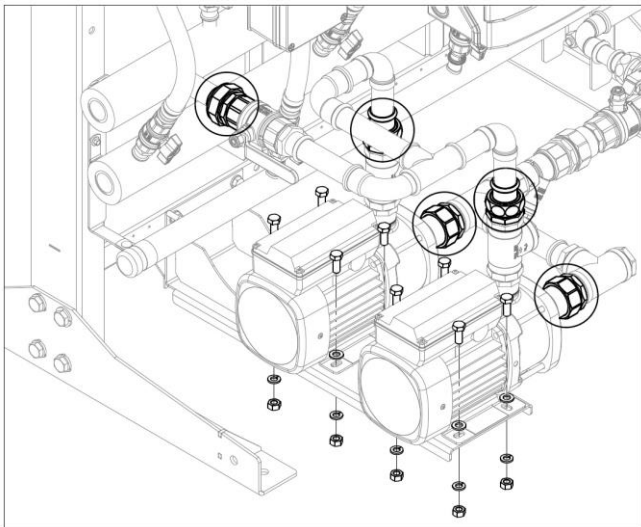

Figure 8b

11. Remove the screws holding the frame base to the timber pallet. For multiple frame systems, disconnect the bolts connecting each frame together:

- 6 from the base members of floor mounted systems. Refer **Figure .**
- 5 from the base members of wall mounted systems.
- 4 from the top lifting brackets. Refer to **Figure 11.**
- 4 from the lower stiffener members. Refer to **Figure 12.**
- 4 from the upper stiffener member of floor and wall mounted systems. Refer to **Figure 3.**

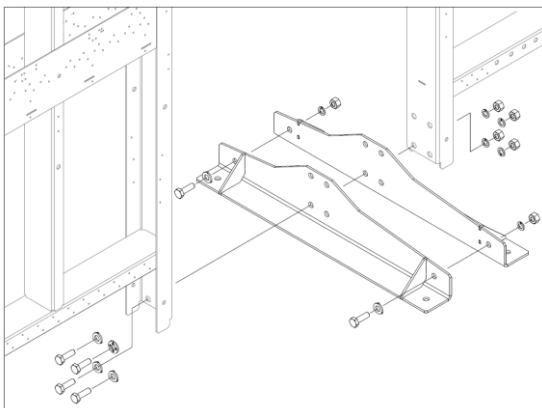

Figure 10

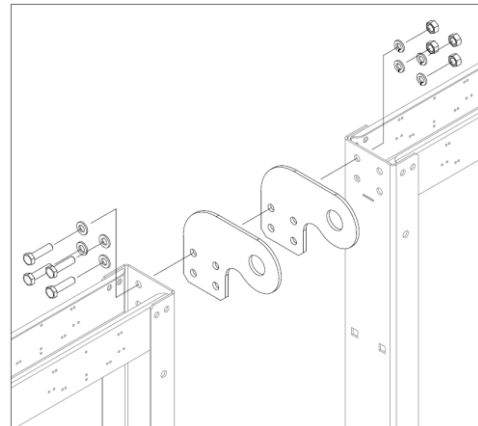

Figure 11

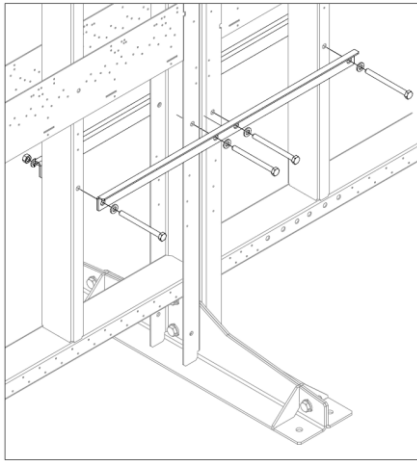

Figure 12

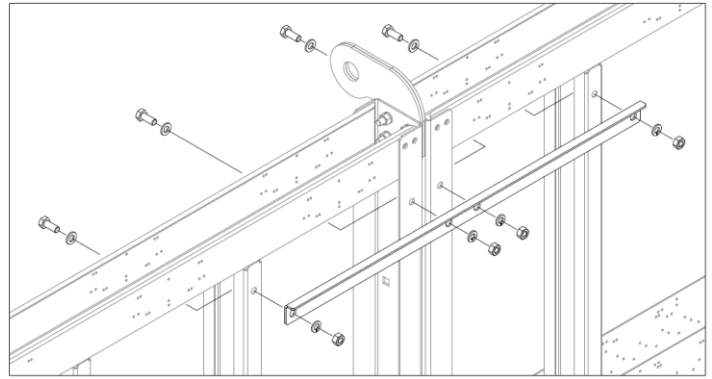

Figure 13

PARTS WEIGHT

- Gas CFWH Rheem 27 litre external = approx 22 kg
- Gas CFWH Rheem 27 litre internal = approx 25 kg
- Frame assembly 2 bay (including pump and manifolds) = 74 kg max
- Frame assembly 3 bay (including pump and manifolds) = 91 kg max
- Frame assembly 4 bay (including pump and manifolds) = 113 kg max
- Frame assembly 2 bay (pump and manifolds removed) = 44 kg max
- Frame assembly 3 bay (pump and manifolds removed) = 53 kg max
- Frame assembly 4 bay (pump and manifolds removed) = 62 kg max
- Primary Pump = 20kg max

FRAME CONFIGURATION

Each Tankpak is made up of one or more frames. Where a system includes unmatched sized multiple frames, configuration is as shown below with the larger frame on the left-hand side. Pump and Main controller are also mounted on the left-hand frame.

Model	Frame Configuration		Frame Lengths
	Floor/Wall Mount	Back to Back	
TP02	2 bay	-	2 Bay = 755mm 3 Bay = 1118mm 4 Bay = 1481mm
TP03	3 bay	-	
TP04	4 bay	2 bay	
TP05	3 bay and 2 bay	3 bay	
TP06	2 x 3 bay	3 bay	
TP07	4 bay and 3 bay	4 bay	
TP08	2 x 4 bay	4 bay	
TP09	3 x 3 bay	3 bay and 2 bay	
TP10	-	3 bay and 2 bay	
TP12	-	2 x 3 bay	
TP14	-	4 bay and 3 bay	
TP16	-	2 x 4 bay	
TP18	-	3 x 3 bay	

12. Relocate the system parts to the required position and rebuild the system. Reassembly is the reversal of the disassembly procedure, starting with the frame reassembly. Ensure no system parts or components are dropped or damaged during re-positioning.
13. All fasteners used for the base member connections must be torqued to 80 Nm. All fasteners used for the lifting lug connections must be torqued to 45 Nm.
14. If the system parts have been left in a disassembled state for any length of time, ensure that all CFWH connections, hose ends and manifolds are clear of any debris or foreign matter.
15. Ensure the frame is structurally sound and that it has been re-assembled exactly as it was received. Ensure all bolts, nuts and washers are installed in original locations and are tightened until the spring washer is fully compressed.

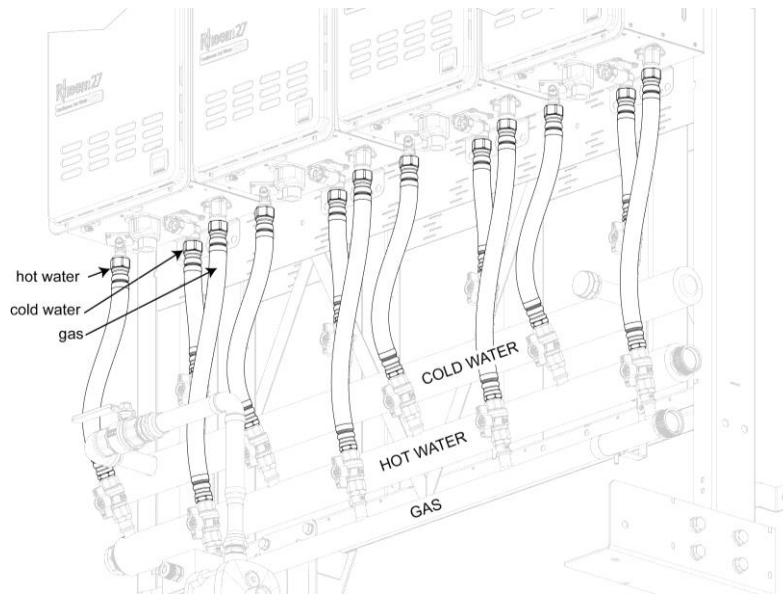

Figure 14

16. Reinstall the water and gas manifolds paying attention to their location. Refer to **Figure 14**.
17. If removed, re-install pump and GPO assemblies, refer to **Figure 15** for pump wiring details

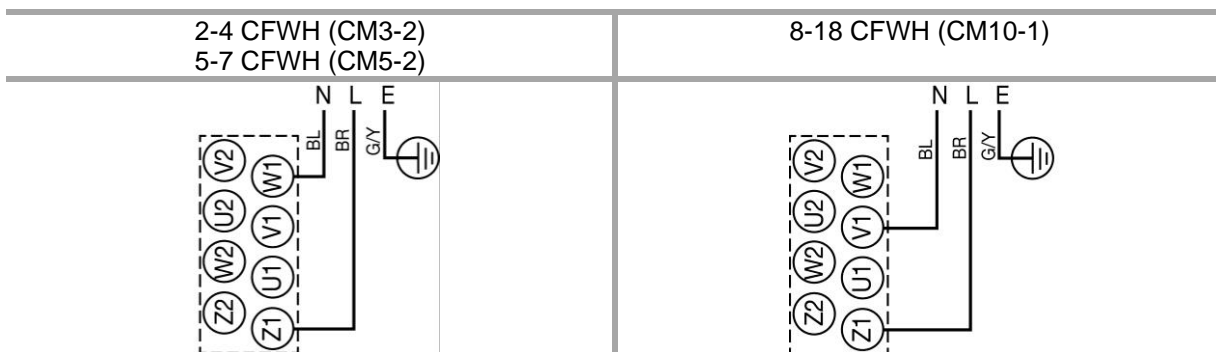

Figure 15

18. Reinstall all CFWH units. There are two hole positions on the top horizontal frame member. Top holes are for mounting internal CFWH units, bottom holes are for mounting external CFWH units. Installing to the wrong hole will either kink the flexible connectors or render them too short. Ensure the cables running from the controller and extension modules are connected back to the PCB on each water heater with correct numbering.
19. Connect the flexible hose connectors to the CFWH units. Ensure all connections into the CFWH units are correct i.e. gas to gas (yellow handle), cold to cold (green handle) and hot to hot (red handle). Do not allow for any flexible connection hoses to be kinked or restrict water or gas flow in any way. Refer to **Figure 4**.
20. Secure cables with new cable ties (not supplied) and check system for completeness.

LIFTING

Frames are designed to be lifted by an overhead crane utilising **all of the frame's lifting lugs** with a maximum included lifting angle of 60°, see **Figure 16** on **page 31**. The crate is designed to be lifted using a forklift while fully assembled. Lifting should only be done in accordance with the installation instructions provided with the system.

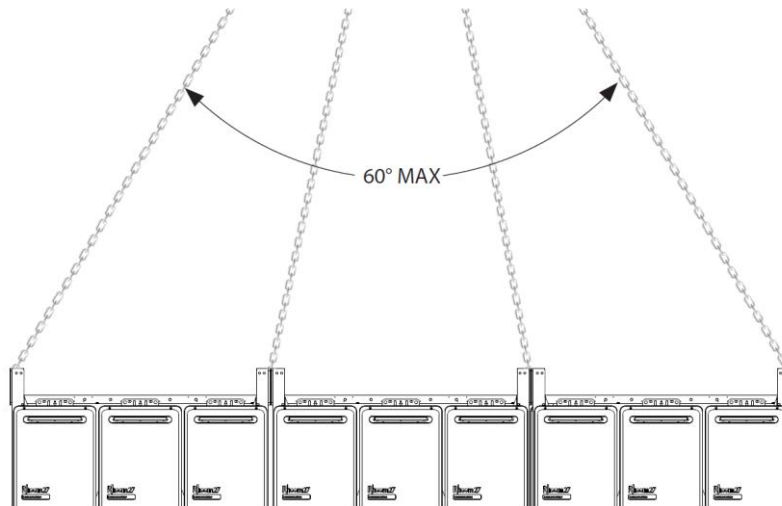

Figure 26

FLOOR AND WALL MOUNTING

Wall mounting requires the frame to be secured to the floor and the wall. Two mounting brackets are packaged with the system to allow the frame to be fixed to the wall. Two (2) Hilti M8 HSL-3 masonry anchors, or equivalent, (not supplied) are to be used for securing the wall mounting brackets to the wall. Anchor Bolts, Ramset DynaBolt Plus Anchor, 12mm (DP12060GH), 40mm embedment, or equivalent, (not supplied) are to be used to secure each base member to the floor.

Floor mounted frames are to be secured to the ground using Ramset DynaBolt Plus Anchor, 12mm (DP12060GH), 40mm embedment, or equivalent, (not supplied). Each base member is to have two (2) anchor points secured to a concrete roof with minimum compressive strength of $f_c=20$ MPa, in order to satisfy the wind load ratings shown on [page 33](#).

All anchors are to be installed to their manufacturer's specifications.

OUTDOOR INSTALLATION

If outdoors, a secondary flue is not required. The water heater must not be installed indoors or in a confined space.

The water heaters must be positioned to ensure that the location of the flue terminals complies with the requirements of AS/NZS 5601.1, as applicable under local regulations. As a guide, the following requirements are extracted from AS/NZS 5601.1. The distances are measured along the wall behind the water heater.

- At least 300 mm between the top of the flue terminal and the eaves.
- At least 500 mm between the flue terminal and the edge of any opening into the building, such as an openable door or window, measured horizontally*.
- At least 1500 mm between the top of the flue terminal and the edge of any opening into the building, such as an openable window, measured vertically.
- At least 300 mm between the flue terminal and a return wall or external corner, measured horizontally*.
- At least 1500 mm between the flue terminal and any opening into a building, in the direction of the flue discharge.
- At least 500 mm between the flue terminal and a fence, wall or other obstruction, in the direction of the flue discharge.

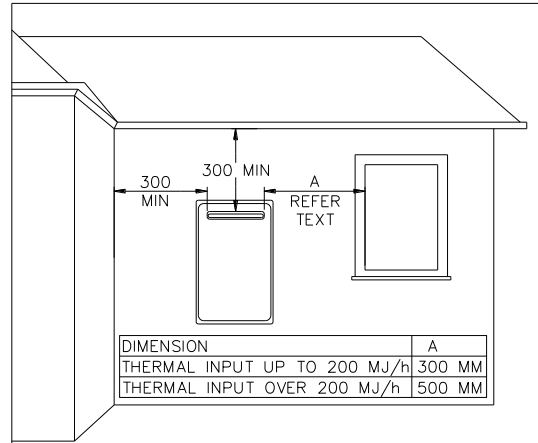

Note: * If these horizontal distances cannot be achieved, AS/NZS 5601.1 states an equivalent horizontal distance measured diagonally from the nearest discharge point of the flue terminal to the opening may be deemed to comply. Check with the local regulator.

Note: Two or more of this model CFWH can be installed side by side with minimal clearance between them. The AGA has approved the installation of two or more of this model CFWH with an exemption from the 300 mm minimum clearance requirements between flue terminals, as stated in AS/NZS 5601.1, clause 6.9.3.

WIND LOADING

Height restrictions apply to outdoor installation of free standing systems as detailed in the table on [page 33](#). Installations outside of the table for outdoor freestanding systems are **not covered by a wind rating certificate**.

MAXIMUM PERMISSIBLE INSTALLATION ROOF HEIGHT - REGION SPECIFIC (AUSTRALIA ONLY)

	Region A	Region B	Region C	Region D
Terrain Category 1	-	-	-	-
Terrain Category 2	45m	45m	-	-
Terrain Category 3	45m	45m	-	-
Terrain Category 4	45m	45m	-	-

Based on Wind Loading to AS/NZS1170.2 with wind average recurrence interval of 500 years

INDOOR INSTALLATION

VENTILATION

This water heater **MUST ONLY** be installed with a certified Rheem coaxial flue system. The kit enables a room sealed installation, drawing air for combustion from outside of the building.

The ventilation of a room or an enclosure such as a cupboard, where the water heater is installed must comply with the requirements of AS/NZS 5601.1, as applicable under local regulations.

Note: The water heater is not designed to be installed within plant rooms that have a negative pressure.

SECONDARY FLUE

A secondary flue must be installed with an indoor water heater to discharge combustion products to outside the building. The water heater **MUST ONLY** be installed with a certified Rheem coaxial flue system.

Where more than one water heater is installed, each water heater must be individually flued using a certified Rheem coaxial flue system. A common flue system **MUST NOT** be used.

Refer to **page 44** for details of flue installation.

SAFE TRAY

Where damage to property can occur in the event of the water heater leaking, the water heater must be installed in a safe tray. Construction, installation and draining of a safe tray must comply with AS/NZS 3500.4 and all local codes and regulatory authority requirements.

FROST PROTECTION

The water heater has a frost protection system. The frost protection system will protect the water heater from damage, by preventing ice forming in the waterways, in the event of freezing conditions.

The frost protection system will be rendered inoperable if electrical power is not available at the water heater. Damage to the water heater caused by freezing of the pipe work to or from the water heater is not covered under the Rheem warranty. Refer to AS/NZS 3500.4 for precautions to be taken for installations in frost prone areas. The water heater is not suitable for installation in areas where the ambient temperature falls below -20°C (including wind chill factor).

PRESET OUTLET TEMPERATURE SETTING

The Tankpak Series 3 controller is factory set to 65°C for the storage tank and the continuous flow water heaters are set to 70°C.

It is usually not necessary to check or adjust the factory preset outlet temperature setting of the water heater, unless the customer or application has a requirement for this to be done.

For applications requiring sanitising temperatures, such as a commercial kitchen, it will be necessary to adjust the preset outlet temperature setting of the controller to achieve and maintain sanitising temperatures up to 82°C. Refer to **page 8 and 68** for details.

If the water heater is installed as part of a circulated hot water flow and return system in a building, the preset outlet temperature setting must be set to at least 60°C. If the water temperature decreases by more than 5°C through a circulated hot water flow and return system due to heat loss in the ring main, the preset outlet temperature setting of the water heater should be set to at least 65°C.

GAS BOOSTER FOR A SOLAR WATER HEATER

Note: AS 3498 requires that a water heater provides the means to inhibit the growth of Legionella bacteria in potable water. When this water heater is used as an in-series booster for a solar water heater it can satisfy this AS 3498 requirement provided it is energised and the booster preset outlet temperature setting is 70°C or higher.

HOT WATER DELIVERY

This water heater can deliver water at temperatures which can cause scalding.

It is necessary and we recommend that a temperature limiting device be fitted into the hot water piping to any ablution and public areas such as a bathroom, ensuite or public amenities when a Tankpak Series 3 water heater is installed to reduce the risk of scalding. The installing plumber may have a legal obligation to ensure the installation of this water heater meets the delivery water temperature requirements of AS/NZS 3500.4 so that scalding water temperatures are not delivered to a bathroom, ensuite or other ablution or public area.

Where a temperature limiting device is installed adjacent to the water heater, the cold water line to the temperature limiting device can be branched off the cold water line either before or after the isolation valve, pressure limiting and non return valve to the water heater. If an expansion control valve is required, it must always be installed after the non return valve and be the last valve prior to the water heater.

If a pressure limiting valve is installed on the cold water line to the storage tank and the cold water line to a temperature limiting device branches off before this valve or from another cold water line in the premises, then a pressure limiting valve of an equal pressure setting may be required prior to the temperature limiting device.

TEMPERATURE LIMITING DEVICE

A temperature limiting device cannot be installed in circulated hot water flow and return pipe work, unless it is specifically designed to do so, such as the Rheem Guardian warm water system. The tempered water from a temperature limiting device cannot be circulated. Where a circulated hot water flow and return system is required in a building, a temperature limiting device can only be installed on a dead leg, branching off the circulated hot water flow and return pipe.

If circulated tempered water were to be returned to the water heater, depending on the location of the return line connection on the water supply line to the water heater, then either:

- Water will be supplied to the cold water inlet of the temperature limiting device at a temperature exceeding the maximum recommended water supply temperature, or
- When the hot taps are closed no water will be supplied to the cold water inlet of the temperature limiting device whilst hot water will continue to be supplied to the hot water inlet of the temperature limiting device.

These conditions may result in either water at a temperature exceeding the requirements of AS/NZS 3500.4 being delivered to the hot water outlets in the ablution areas, or the device closing completely and not delivering water at all, or the device failing. Under either condition, the operation and performance of the device cannot be guaranteed.

SYSTEM COMPONENTS

CONTROLLER

Enclosure

The controller enclosure has a protection rating IP34 and can be installed indoors or outdoors. To aid with visualisation of the control panel, it is recommended to not install the water heater such that the controller will be in direct sunlight.

Temperature Sensors - The controller senses the storage cylinder water temperature and determines whether the continuous flow water heaters (CFWH) should be switched on or off, via the primary pump. For the Deluxe controller adjustments can be made to the parameters from the front controller knob. For the Standard controller adjustments can be made via dip switches located inside the controller enclosure. The sensor is connected to the controller via a 10m double insulated lead which must be installed in the thermostat well within one of the storage tanks.

The Deluxe controller is also equipped with two additional temperature sensors, measuring hot water flow to the building and the water return from the building. If the system is provided with the UPM 3 or the UPM XL secondary pump assembly, the building return sensor is factory fitted to the pump assembly.

Pump Control Relay – The pump is operated via a relay capable of handling the maximum current of the range of pumps supplied with Tankpak.

Circuit Breaker - a 10Amp circuit breaker is provided within the controller to provide short circuit protection to the pump and controller PCB circuits. It is **NOT** a system isolator.

Pump – One or two Grundfos CM primary pump/s is factory fitted and wired to the assembly. The pump is sized according to the number of CFWH and with the tank(s) in relative proximity to the frame assembly. The pump is supplied with TP 211 type B thermal protection in the windings. The pump must be replaced, if necessary, with like pump.

Secondary pumps may be provided with systems incorporating the Deluxe controller. Grundfos UPM3 and UPMXL pumps are attached to the right hand vertical member of the frame assembly. CM3-2 used as secondary pumps are provided pre-plumbed on a separate skid, requiring plumbing and electrical connections made by the installer. The power to all pumps is drawn from the controller terminal blocks. Pumps with greater power consumption than CM3-2 may be used as secondary pumps and operated by the controller, provided that contactors are used.

Continuous Flow Water Heaters – CFWH supplied with this assembly could be indoor or outdoor, natural gas or propane or ULPG in New Zealand. Each CFWH has a gas input rating of 205MJ/hr and must be replaced, if necessary, with like water heaters.

General Purpose Outlets – 240V GPOs are provided on the frame assembly to provide power to the CFWH. Power is drawn from the junction box. Refer to [page 61](#) for details.

Junction box – A junction box is provided on the frame assembly to provide power to the GPOs and the controller. Push-in type terminal blocks are mounted on a DIN rail inside the junction box. A 10A plug & lead is factory fitted to the junction box terminals for all Standard models (TP02-06) and Deluxe models TP02-04 (with up to 2 x UPM XL secondary circulators). Systems not provided with a plug & lead must be hardwired to the vacant terminals in the junction box by a suitably qualified person.

TANKPAK SERIES 3 INSTALLATION

GENERAL

Follow the instructions supplied with the water storage tank for general installation requirements including, water quality and maintenance requirements.

All packaging materials must be removed from the water heater and storage tank prior to its installation.

Warning! The system must not be turned on until all connections have been made and the system has been charged with water and purged of air. Failure to do so can lead to electric shock and/or failure of the pump.

OPERATION

Tankpak Series 3 operates on the top down heating principle. This ensures the coldest water is always supplied to the CFWH to maximise thermal input and recovery. On a call for heat, the controller energises the primary pump, the flow from which in turn causes the CFWH to fire. The rate of fire will depend on the temperature set point, the flow rate from the pump and the incoming water supply temperature. Water at the set temperature of the CFWH will enter the top of the storage tank or the hot water delivery to the building (or both depending on system dynamics) and heat the storage tank from the top down, until a temperature above the controlling set point is sensed at the storage tank, at which time the pump will be de-energised and the CFWH will shut down.

The controller also features algorithm to stage and rotate CFWH operation. The staging allows only a certain number of water heaters to operate for given building demand based on storage tank temperature. For example, when there is a call for heat due to building ring main heat loss, the tank temperature sensor reading may only be lower than the set point by the set differential. In such instance, only a small number of water heaters will operate to heat the water in the storage tank. If the hot water is drawn off from the storage tank and the storage tank temperature drops below the set point by a greater amount, the controller stages up and allows more water heaters to operate to keep up with the demand. The rotation algorithm of water heaters ensures that the cumulative hours of operation of each CFWH is kept to a comparable amount in order to maintain uniform usage of water heaters.

Tankpak Series 3 Deluxe systems are equipped with a temperature sensor to measure the building return temperature. When the reading of the return sensor drops below the building set point by the set differential, the controller energises the secondary pump which circulates the water in the building ring main and hot water from the storage tank flows into the ring main. When the temperature reading of the return sensor reaches the set point, the controller de-energises the secondary pump, ceasing flow in the ring main.

For Deluxe models not specified with on board duty/standby building circulators, the building return sensor acts as an indicator only and is to be installed on the system pipe work by the installer. Refer to Temperature Sensor Probes on [page 43](#).

Tankpak Series 3 Deluxe systems are equipped with a temperature sensor to measure the flow temperature to the building. This sensor is an indicator only and has no functional output. It is to be installed on the system pipe work by the installer. Refer to Temperature Sensor Probes on [page 43](#).

CONNECTIONS – PLUMBING

PLUMBING CONNECTIONS

All plumbing work must be carried out by a qualified person and in accordance with the National Plumbing Standard AS/NZS 3500.4 and local authority requirements.

All gas work must be carried out by a qualified person and in accordance with the Australian Gas Installations Standard AS/NZS 5601.1 and local authority requirements.

PIPE SIZING

The pipe sizing for hot water supply systems should be carried out by persons competent to do so, choosing the most suitable pipe size to ensure adequate flow for each individual application. Reference to the technical specifications of the water heater and local regulatory authority requirements must be made.

To achieve true mains pressure operation, the cold water line to the water heater should be the same size or bigger than the hot water line from the water heater.

The table below specifies the minimum cold water and hot water manifold header pipe size required between the CFWH and the storage tank(s) and the minimum gas manifold pipe size for typical installations. The design allows for 8m total flow and return between Tankpak and storage tanks (excluding manifolding) and 12 x 90 degree bends, with 1.2m/sec velocity.

An isolation valve and non return valve and line strainer must be installed on the cold water supply to the system, A PLV and/or ECV may also be required. A full flow isolation valve/ball or gate disconnection union must be installed on the inlet and outlet of the storage tank(s).

Note: The system is supplied with a line strainer on the inlet of the Tankpak Series 3 package.

A pressure limiting valve must be fitted if the water supply pressure exceeds 80% of the storage tank temperature and pressure relief valve or expansion control valve setting, whichever is the lower.

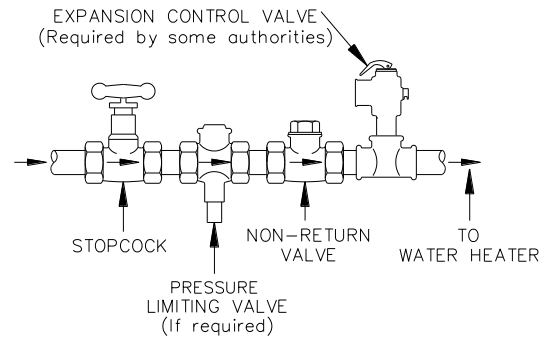

Tankpak Model ¹	Thermal Input (MJ/hr)	Minimum Primary Flow and Return Pipe Size (mm)	Gas Pipe Connection (mm)		Primary Pump Model
			In Line	Back to Back	
TP02	410	25	40	-	CM3-2
TP03	615	32	40	-	CM3-2
TP04	820	40	40	40	CM3-2
TP05	1025	40	50	40	CM5-2
TP06	1230	40	50	40	CM5-2
TP07	1435	50	50	50	CM5-2
TP08	1640	50	50	50	CM10-1
TP09	1845	50	50	65	CM10-1
TP10	2050	50	-	65	CM10-1
TP12	2460	50	-	65	CM10-1
TP14	2870	65	-	65	CM10-1
TP16	3280	65	-	65	CM10-1
TP18	3690	65	-	80	CM10-1

¹includes TP models for Australia and equivalent TZ models for New Zealand

VIBRATION NOISE

All plumbing within a building must be appropriately isolated to limit noise transference due to vibration. Additionally, air in the system is a major contributor to 'pump noise'. An air eliminator (manual or automatic) must be installed at the highest point within the building to allow the expulsion of entrained air. We recommend rubber isolation pads be fitted under the feet and wall brackets (wall mounted units) to limit any

possible pump vibration.

PIPE CONNECTION BETWEEN SOLAR STORAGE TANK/S AND TANKPAK IN-SERIES BOOSTER

The pipe work between the solar storage tank (if one is installed) and the in-series gas booster, **MUST BE** of copper and be fully insulated with a closed cell type insulation or equivalent in accordance with the requirements of AS/NZS 3500.4.

The insulation must be weatherproof and UV resistant if exposed. The insulation must be fitted up to the connections on the solar storage tank.

All pipe work must be cleared of foreign matter before connection and purged before attempting to operate the water heater. All olive compression fittings must use brass or copper olives. Use thread sealing tape or approved thread sealant on all other fittings.

WATER HEATER CONNECTIONS

Connect the water heater and storage tank(s) in accordance with the principles shown in the diagram on **page 39** with the following in mind:

Install the storage tanks according to Equa-flow® principles as described in the installation instructions supplied with the storage tanks.

A disconnection union must always be provided at the cold water inlet, hot water outlet and gas connection to the assembly to allow for disconnection of the system

610 Series storage tanks have a plastic fitting liner in the inlet fitting and plastic dip tube in outlet fitting (see diagram). These must be in place for the storage tank to function properly. Do not remove or damage them by using heat nearby. They will be pushed into the correct position as the fitting is screwed in.

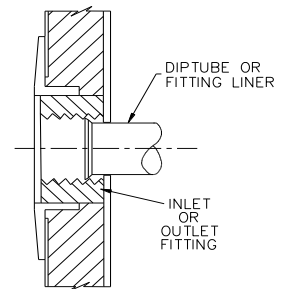

EXPANSION CONTROL VALVE

Local regulations may make it mandatory to install an expansion control valve (ECV) in the cold water line to the water heating system. In other areas, an ECV is not required unless the saturation index is greater than +0.4 (refer to 'Water Supplies' in the Instructions supplied with the storage tank). However, an ECV may be needed in a corrosive water area where there are sufficient quantities of silica dissolved in the water.

The expansion control valve must always be installed after the non return valve and be the last valve installed prior to the water heater (refer to diagram on **page 39**). A copper drain line must be run separately from the drain of the relief valve.

MAINS WATER SUPPLY

Where the mains water supply pressure exceeds that shown in the table below, an approved pressure limiting valve is required and should be fitted.

	610 Series	RT Series
Temperature & Pressure Relief valve setting	1000 kPa	850kPa
Expansion control valve setting*	850 kPa	700kPa
Max. mains supply pressure		
Without expansion control valve	800 kPa	680
With expansion control valve	680 kPa	550
* Expansion control valve not supplied with storage tank		

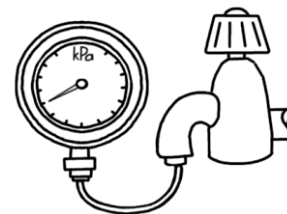

Notes:

- When installed with Rheem 610 series storage tanks, the maximum water supply pressure, without an expansion control valve (ECV), is 800 kPa, however it may be less than this if used with other storage tank models. Refer to the Owner’s Guide and Installation Instructions supplied with the storage tank for maximum mains supply pressure details.
- This water heater is not suitable for connection to bore water or spring water unless a water treatment device is fitted.
- Refer to “Water Supplies” on **page 13** for further information on water chemistry.

TANKPAK SERIES 3 - TYPICAL INSTALLATION DIAGRAMS

TYPICAL INSTALLATION RHEEM COMMERCIAL TANKPAK STANDARD CONTROLLER WITH SINGLE TANK

WIDTH	No OF HEATERS					
	2	3	4	5	6	
	Inline (mm)	755	1118	1481	1844	2207
Back to Back (mm)	-	-	755	1118	1118	

ALL DIMENSIONS ARE REFERENCE ONLY

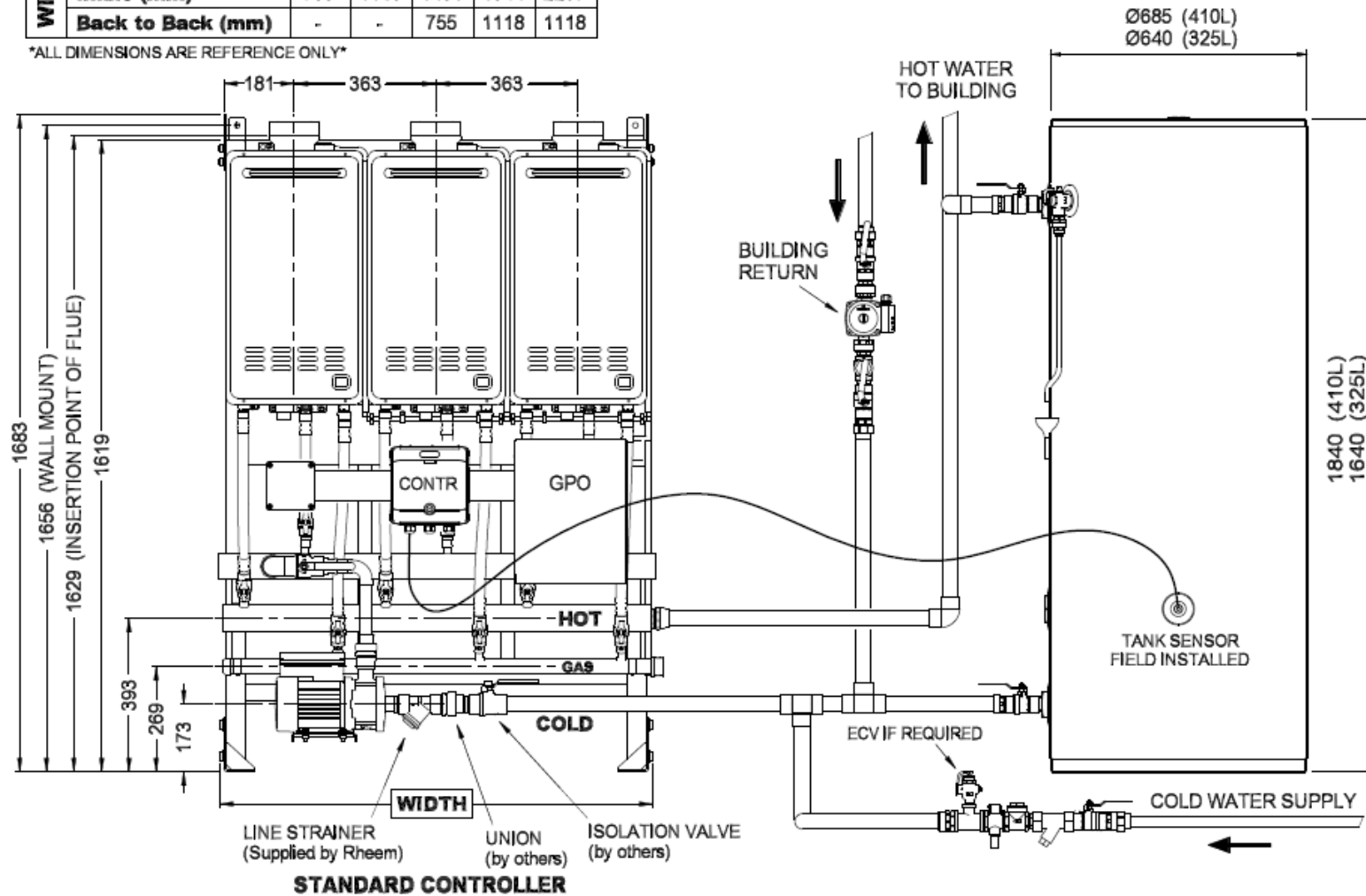

TYPICAL INSTALLATION RHEEM COMMERCIAL TANKPAK DLEXUE CONTROLLER WITH SINGLE TANK

WIDTH	No OF HEATERS	2	3	4	5	6	7	8	9	10	12	14	16	18
Inline (mm)		755	1118	1481	1844	2207	2570	2933	3296	-	-	-	-	-
Back to Back (mm)		-	-	755	1118	1118	1481	1481	1844	1844	2207	2570	2933	3296

ALL DIMENSIONS ARE REFERENCE ONLY

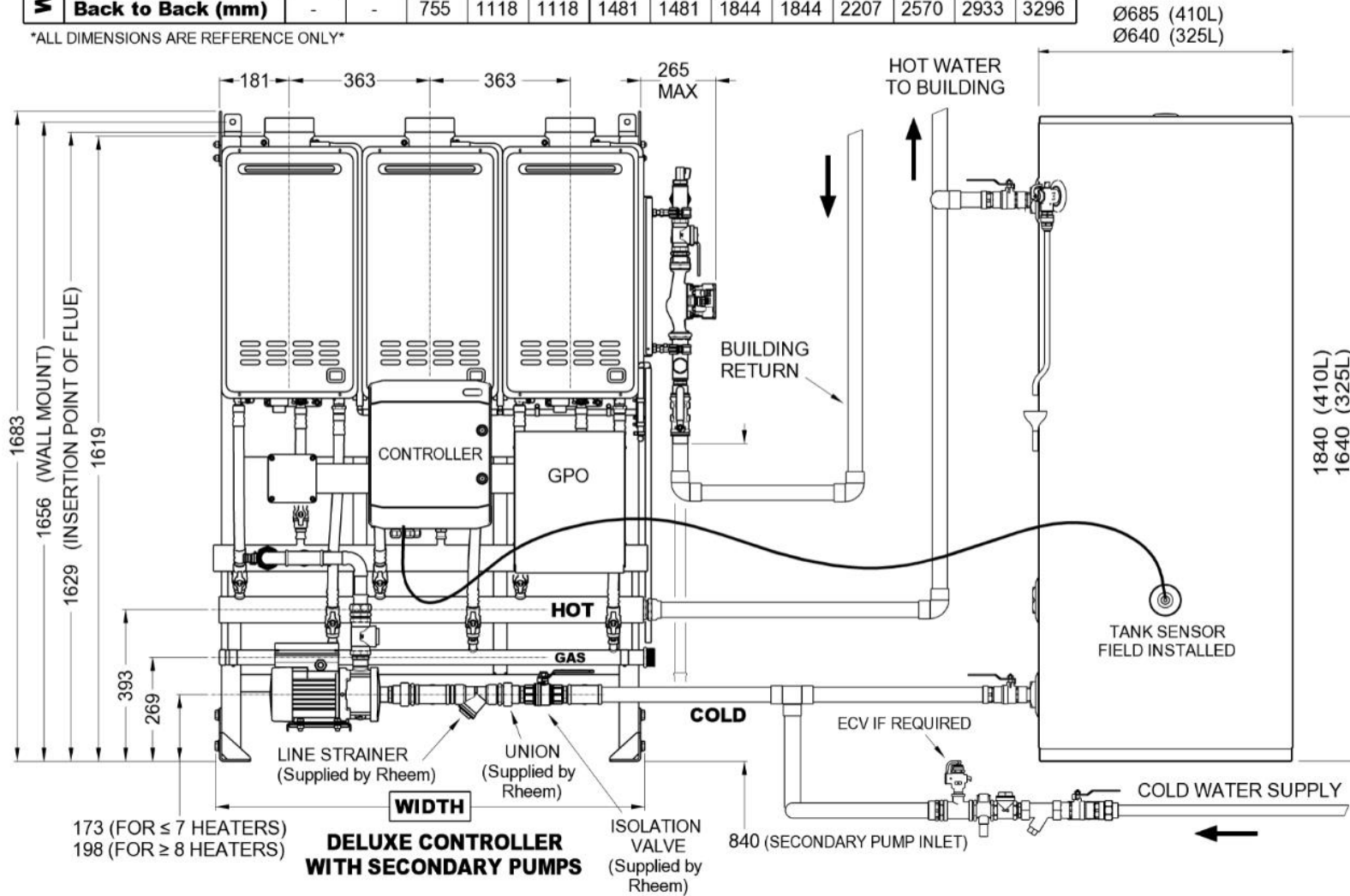

TYPICAL INSTALLATION RHEEM COMMERCIAL TANKPAK DELUXE CONTROLLER WITH MULTIPLE TANKS

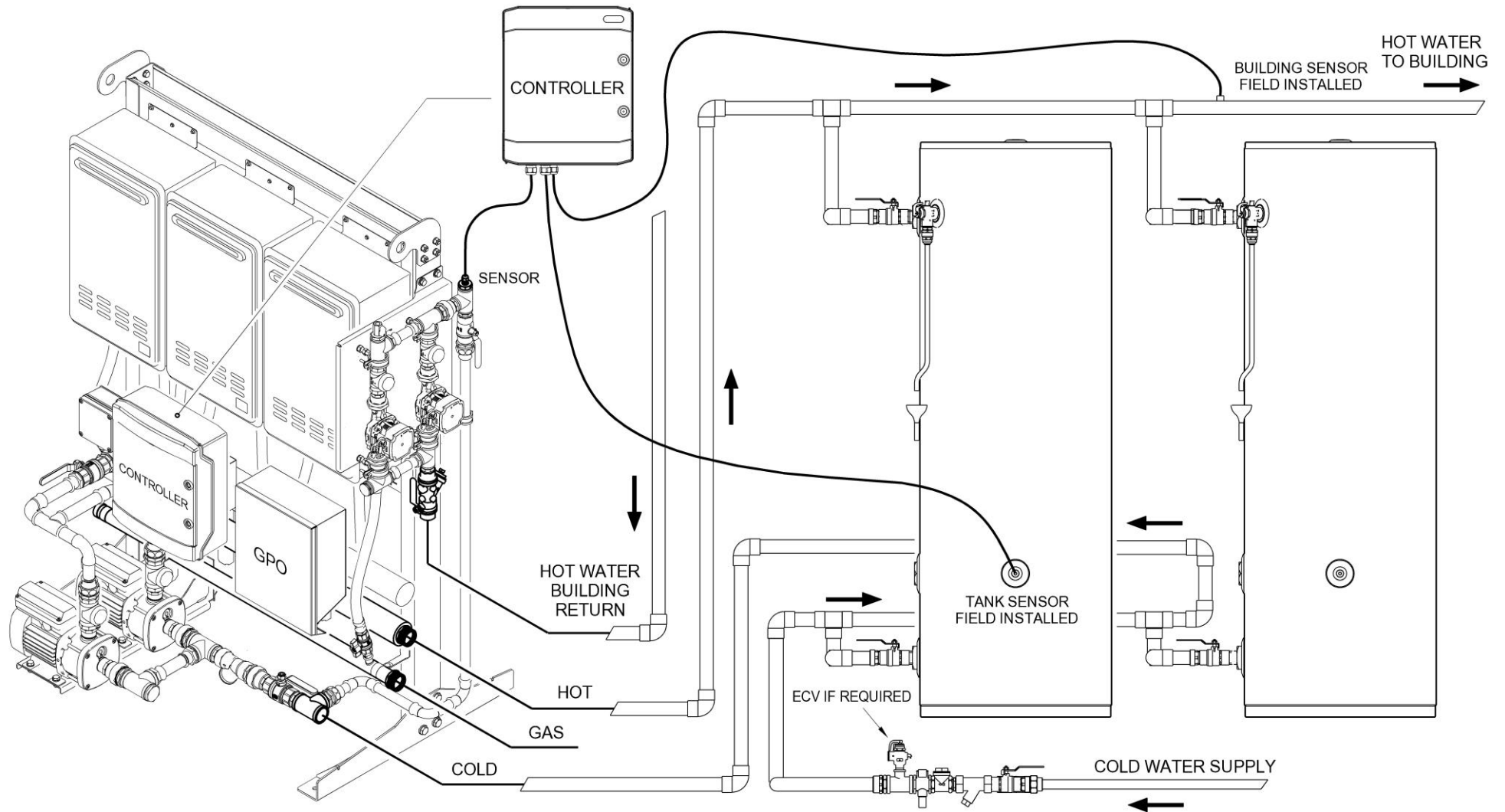

TYPICAL INSTALLATION RHEEM COMMERCIAL TANKPAK DELUXE CONTROLLER WITH RHEEM GUARDIAN

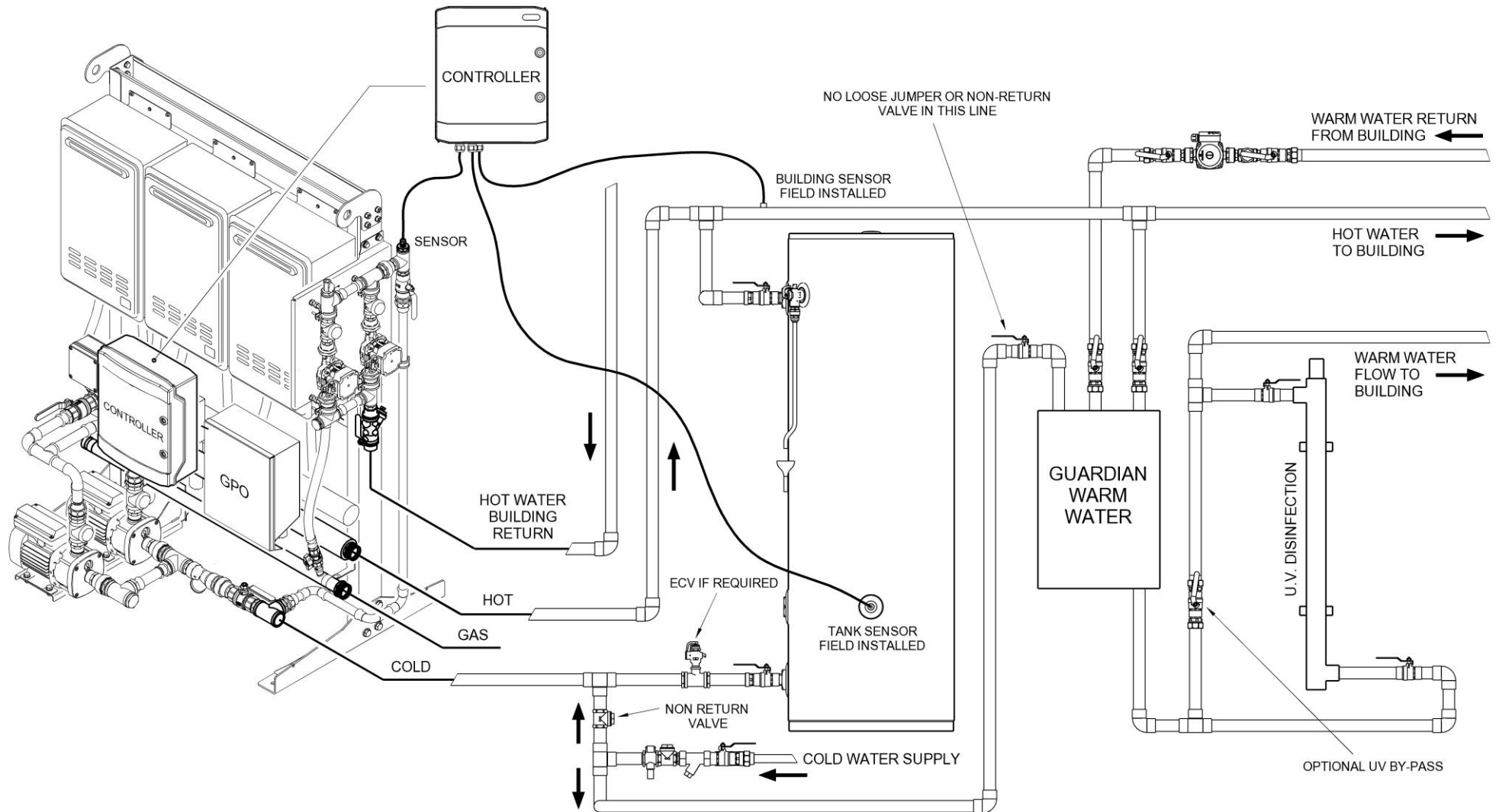

RELIEF VALVE DRAIN

A copper drain line must be fitted to the relief valve to carry the discharge clear of the storage tank/s. Connect the drain line to the relief valve using a disconnection union. The pipe work from the relief valve to the drain should be as short as possible and fall all the way from the water heater with no restrictions. It should have no more than three right angle bends in it. Use DN20 pipe.

The outlet of the drain line must be in such a position that flow out of the pipe can be easily seen (refer to AS/NZS 3500.4) - but arranged so hot water discharge will not cause injury, damage or nuisance. The drain line must discharge at an outlet or air break not more than 9 metres from the relief valve.

In locations where water pipes are prone to freezing, the drain line must be insulated and not exceed 300 mm in length. In this instance, the drain line is to discharge into a tundish through an air gap of between 75 mm and 150 mm.

For multiple installations, the drain line from each storage tank can discharge into a common tundish.



As the function of the temperature pressure relief valve on this water heater system is to discharge high temperature water under certain conditions, it is strongly recommended the pipe work downstream of the relief valve be capable of carrying water exceeding 93°C. Failure to observe this precaution may result in damage to pipe work and property.

GAS INLET

The pipe work must be cleared of foreign matter before connection and purged before attempting to light the water heater. An isolation valve and disconnection union must be used to allow servicing and removal of the water heater.



Always isolate the water heater before pressure testing the gas supply system. Disconnect the water heater after the isolating cock to prevent the risk of serious damage to the gas train. Warranty does not cover damage of any nature resulting from failure to observe this precaution. Refer to the rating label for gas types and pressures.



The heater and its gas connection must be thoroughly leak tested before placing in operation. Use soapy water and a manometer for leak test.

DANGER! Do not use an open flame to check for gas leaks

Note: Refer to the Gas Installations Standard AS/NZS 5601.1 for the correct method of sizing the gas supply pipe to the water heater. The pipe size selection must consider the high gas input of this water heater as well as all of the other gas appliances in the premises.

TEMPERATURE SENSOR PROBE/S

The supplied sensor/s are 10m long. The storage tank must be within 10m of the controller otherwise the sensor must be extended using Rheem 20m extension cable P/No 052543 (ordered separately).

Tank Sensor

For 610 series storage tanks, remove the plastic cover to expose the thermowell, which is located at the front of the storage tank. Discard the plastic cover. For RT tanks, fit the thermowell to the tank using sealing compound at the required location (usually the bottom sensor fitting). Insert the sensor marked 'TANK' all the way into the thermowell.

A cable tie, clamp and screw are provided in the bag with the installation instructions. Secure the sensor to the tank to prevent the sensor from inadvertently being dislodged.



Building Flow Sensor and Building Return Sensor (Deluxe Models)

The building flow sensor, marked 'FLOW' may either be fitted in a thermowell that sits within the flow of water (not supplied) or clamped to the hot water flow pipe using a pipe clamp and heat paste (not supplied). If clamped to the pipe, the sensor must be fully insulated to ensure accurate temperature reading.

The return sensor marked 'RETURN' is factory fitted on Deluxe models supplied with building circulators. If building circulators are not supplied, fit the sensor marked 'RETURN' as per the instructions for the 'FLOW' sensor.

FLUEING

SECONDARY FLUE

A secondary flue must be installed with an indoor water heater to discharge combustion products to outside the building. The water heater **MUST ONLY** be installed with certified Rheem coaxial flue components carrying the label opposite. **DO NOT** use any other type of flue parts.

Where more than one water heater is installed, each water heater must be individually flued using certified Rheem coaxial flue components.



A common flue system **MUST NOT** be used.

The installation of the secondary flue must be carried out by a qualified person and be in accordance with the Gas Installations Standard AS/NZS 5601.1, as applicable under local regulations, local authority requirements and the installation instructions. A charge will be made for any service related call due to the installation of the flue system not complying with these installation instructions.

The water heater must be flued separately from all other appliances and flued to the outdoors. Minimum clearance requirements apply from the flue terminal in accordance with AS/NZS 5601.1 (refer also to "Flue Terminal Location" on [page 46](#)). Do not install the flue to discharge into a chimney. There is no requirement on the flue to maintain a minimum distance from combustible materials.



Warning: Where the flue penetrates through walls, floors or ceilings, the penetration must comply with local regulations for fire rating. The coaxial flue system does not have nor provides a fire rating.

The water heater flue may be terminated either through the wall with a Horizontal Flue Terminal or through the roof with a 90 degree bend and a Horizontal Flue Terminal. The secondary flue must be self supporting and not impose a load on the water heater.

Flue runs must be adequately supported along both horizontal and vertical runs. The maximum recommended unsupported span for a horizontal run should be no more than 2.0 m. Support isolation hanging bands should be used. Do not use wire. Wall Brackets (PN 295129) are available and should be used for vertical runs. The coaxial flue components are to be connected together using the screws provided. The flue outside diameter is 127 mm.











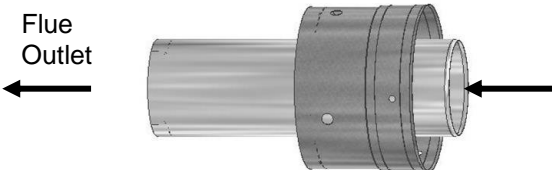

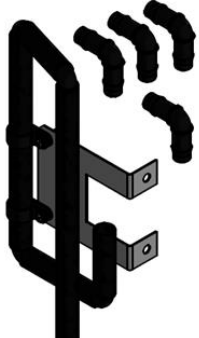

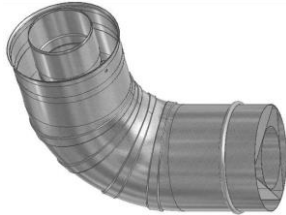
Warning: Never operate the water heater unless it has been installed in accordance with the installation instructions. Failure to install the water heater in accordance with the installation instructions, properly flueing the water heater to the outdoors and ensuring it has an adequate air supply, will result in unsafe operation of the water heater, possibly causing fire, explosion, serious injury and asphyxiation from carbon monoxide.

A sealing gasket is located at one end of the inner flue. Check all flue components to ensure the gasket is in place and properly seated. **DO NOT** install if any gaskets are missing. Contact Rheem Service or their nearest Accredited Service Agent if the gasket is missing.

COMPONENTS

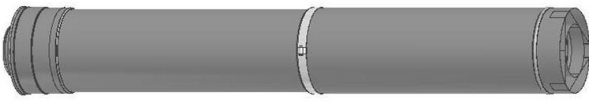
A complete flue system is comprised from the following components.

<p>horizontal flue terminal (PN 295146)</p> 	<p>trim ring (PN 295125)</p> 
<p>condensate trap assy (PN AS33121006) Supplied on frame</p> 	<p>condensate tube assy (PN AS33121007) Supplied on frame</p> 
<p>90° elbow (PN 295147)</p> 	<p>45° elbow (PN 295148)</p> 
<p>straight length – 300 mm (PN 295152)</p> 	<p>wall bracket (PN 295129)</p> 
<p>male to male (MM) adapter (PN 295151)</p> 	<p>female to female (FF) adapter (PN 295150)</p> 
<p>adjustable straight length – 560 to 890 mm (PN 295153)</p> 	<p>straight length – 900 mm (PN 295149)</p> 

FLUE TERMINAL LOCATION

The water heater must be located to ensure that the location of the flue terminal complies with the requirements of AS/NZS 5601.1, as applicable under local regulations. As a guide the following requirements are extracted from the Gas Installations Standard. The distances are measured along the wall from the flue penetration.

Flueing Through the Wall

- At least 300 mm between the top of the flue terminal and the eaves.
- At least 300 mm between the bottom of the flue terminal and the ground, balcony or other surface.
- At 500 mm between the flue terminal and the edge of any opening into the building, such as an openable door or window, measured horizontally*.
- At least 1500 mm between the top of the flue terminal and the edge of any opening into the building, such as an openable window, measured vertically.
- At least 300 mm between the flue terminal and a return wall or external corner, measured horizontally*.
- At least 1500 mm between the flue terminal and any opening into a building, in the direction of the flue discharge.
- At least 500 mm between the flue terminal and a fence, wall or other obstruction, in the direction of the flue discharge.
- At least 300 mm between the flue terminal and any other flue terminal, cowl or other combustion air intake.

Note: * If these horizontal distances cannot be achieved, AS/NZS 5601.1 states an equivalent horizontal distance measured diagonally from the nearest discharge point of the flue terminal to the opening may be deemed to comply. Check with the local regulator.

For a multiple unit installation, refer to “[Horizontal Flue Terminations](#)” on [page 58](#) for minimum distances between flue terminals.

Flueing Through the Roof

- At least 300 mm between the underside of the flue terminal and the nearest part of a non-trafficable roof.
- At least 1500 mm between the top of the flue terminal and the edge of any opening into the building, such as an openable window, measured vertically.
- At least 500 mm between the flue terminal and any building structure or obstruction facing the terminal, measured horizontally.
- At least 1500 mm between the flue terminal and the edge of any opening into the building, measured horizontally.
- At least 300 mm between the flue terminal and any other flue terminal, cowl or other combustion air intake.

For a multiple unit installation, refer to “[Flueing Through the Roof](#)” on [page 58](#) for minimum distances between flue terminals.

FLUE LENGTHS

Maximum Flue Length

The system will not operate if there is excessive restriction (pressure drop) in the flueing system.

The certified flue length is 9m with a maximum of 3 x 90° elbows.

- The maximum flue length with no elbows can be 13.5m.
- Reduce the maximum length by 1.5m for every 90° bend and by 0.75m for every 45° elbow
- The flue must be installed with a gradient of 20 mm per metre of horizontal run (1; 50 fall)

Note: Ensure the seam of the inner flue in horizontal runs is at the top of the installation.

Minimum Flue Length

The minimum horizontal flue distance which may be used is 300 mm, provided:

- One 90° Elbow is connected to the flue outlet of the water heater, and
- The Horizontal Flue Terminal is connected to the 90° Elbow.

FLUE CONDENSATE

Condensate from the combustion gases may form in the flue. The flue outlet assembly at the top of the water heater incorporates a condensate drain spigot to allow for draining of this condensate.

This spigot is covered by a rubber cap held in position by a clamp. For certain types of installations, it will be necessary to remove the clamp and cap and create connection to the condensate manifold assembly built in with the system. Refer to Figure 17.

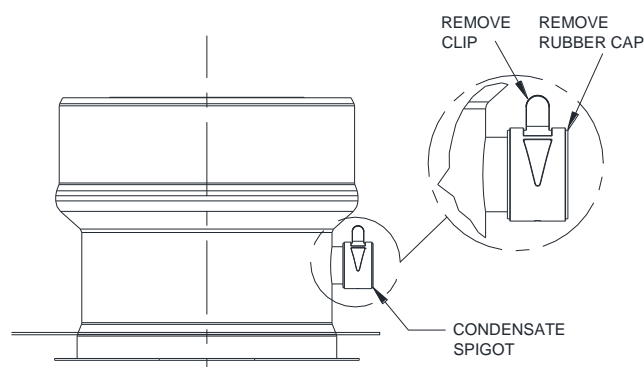

Figure 37 - Condensate Drain Spigot

The Condensate Trap must be filled with water prior to the operation of the water heater. Refer to [Figure 18- Condensate Trap and Condensate Drain Line](#) on [page 48](#).

DRAINING THE CONDENSATE

The connection to the condensate manifold assembly must be made under the following conditions in order to prevent condensate from draining back into the water heater:

- Where vertical sections exceeding 2 m are incorporated in a horizontally terminating flue system.
- Where the flue terminates vertically.
- Where there is a horizontal run of flue between two elbows and the elbow closest to the flue terminal is orientated upward. Refer to [Figure 20- Typical Installation Horizontal Terminal with Multiple Vertical and Horizontal Sections](#) on [page 50](#). This horizontal run of flue must have a gradient upward to the flue terminal. Condensate will drain back toward the water heater.

If the flue installation is outside of above conditions, the connection to the condensate manifold must not be made. The clamp and the rubber cap is to remain on the water heater spigot for such flue installation.

Failure to discharge build-up of condensate in flues could allow acidic flue gas condensate to enter into the water heater flue-way, causing premature failure of the water heater. Any resultant faults will not be covered by the Rheem warranty.

Note: A horizontal run of flue connecting directly to a Horizontal Flue Terminal must have a gradient downward to the flue terminal. Condensate will drain from the flue terminal.

CREATING CONNECTION TO CONDENSATE MANIFOLD ASSEMBLY

Where the installation requires connection to the condensate manifold assembly:

1. Remove the clamp and rubber cap from the condensate drain spigot on the water heater flue outlet. Discard the clamp and the rubber cap as shown in [Figure 37 - Condensate Drain Spigot](#).
2. Undo the strap holding the aluminium tube and fit the end of the short silicone tube to the spigot of the water heater flue outlet as shown in [Figure 18- Condensate Trap and Condensate Drain Line](#).
3. Check that silicone tubes are not kinked, twisted or pinched.
4. Slowly fill the condensate trap with water from the short silicone tube on the rightmost condensate elbow assembly. Observe that water freely discharges from the outlet of the condensate trap. Fit the short silicone tube back to the water heater spigot.
5. Repeat the above water filling procedure on the rear condensate manifold for back-to-back systems.
6. Check for any water leaks from the condensate manifold.
7. Direct the end of the condensate trap tube to appropriate discharge point. The end of the condensate trap tube may be cut to suit. Two (2) loose plastic elbows (per trap) are provided with the system for convenience.

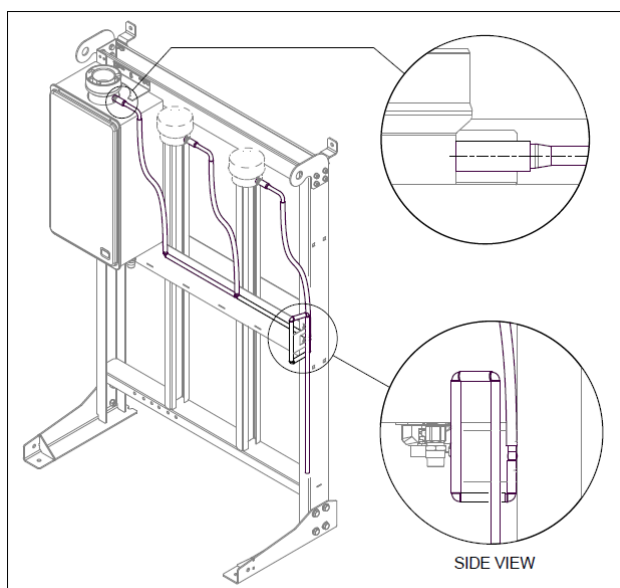

Figure 18- Condensate Trap and Condensate Drain Line

⚠ Warning: Failure to fill with water may cause flue gasses to escape through the condensate trap. Check regularly to ensure the condensate trap is filled with water, replenishing when required.

⚠ Warning: Do not remove or tamper with the condensate trap. Only the end tube of the condensate trap may be cut to aid in directing the discharge point.

Notes

AS/NZS 3500.4 section 5.12 is used as a guide in preparing the following drainage recommendations.

As the condensate is mildly acidic, copper tube and fittings must not be used as they will corrode.

Use UPVC (Unplasticised Polyvinyl Chloride) or PE (polyethylene) piping.

The drain line must not discharge onto electrical connections, earth stakes, copper pipe, concrete paths or into a pond.

HORIZONTAL FLUE RUNS

There are a number of basic installation requirements which must be followed for a flue installation incorporating horizontal flue runs.

Failure to observe these precautions can lead to the premature failure of the flue system and / or water heater.

- The flue must be installed with the seam of the inner flue toward the top of the installation.
- A horizontal section of flue must be installed with a gradient of 20 mm per metre (1 in 50 or 1° fall) of horizontal run.
- A horizontal run of flue between two elbows, where the elbow closest to the flue terminal is **orientated upward**, must have a gradient upward to the flue terminal.
 - Condensate will drain back toward the water heater. Connection to the condensate manifold must be made where the horizontal flue is installed with an upward gradient. Refer to **“Draining the Condensate”** on **page 47**.

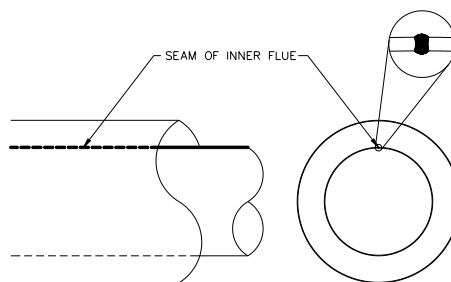

This ensures any condensate formed during operation of the water heater is prevented from draining back into the water heater.

- A horizontal run of flue connecting directly to a Horizontal Flue Terminal must have a gradient downward to the flue terminal.

This prevents rainwater from entering the flue draining back into the water heater.

- Use Male to Male and Female to Female Adapters to reverse the direction of flue insertion where three or more sections of flue are used in a horizontal flue run and the flue drains toward the flue terminal. Refer to **Figure 19- Typical Installation – Horizontal Terminal with One Elbow** on **page 49**.

This provides for proper draining of condensate without pooling at the flue component joins.

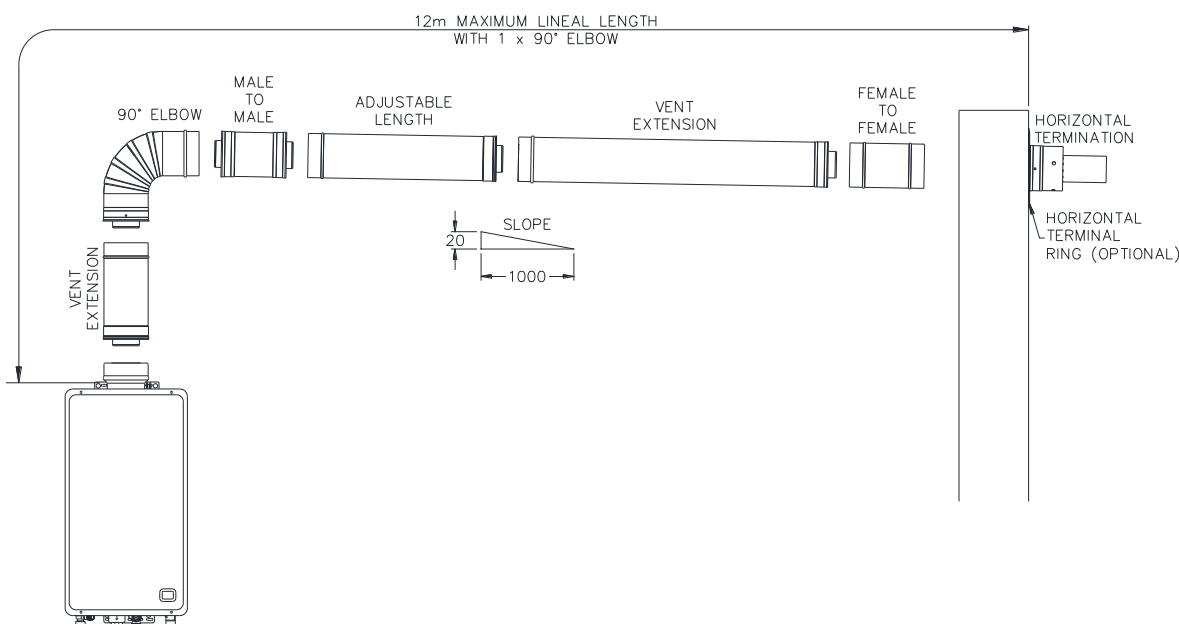

Figure 19- Typical Installation – Horizontal Terminal with One Elbow

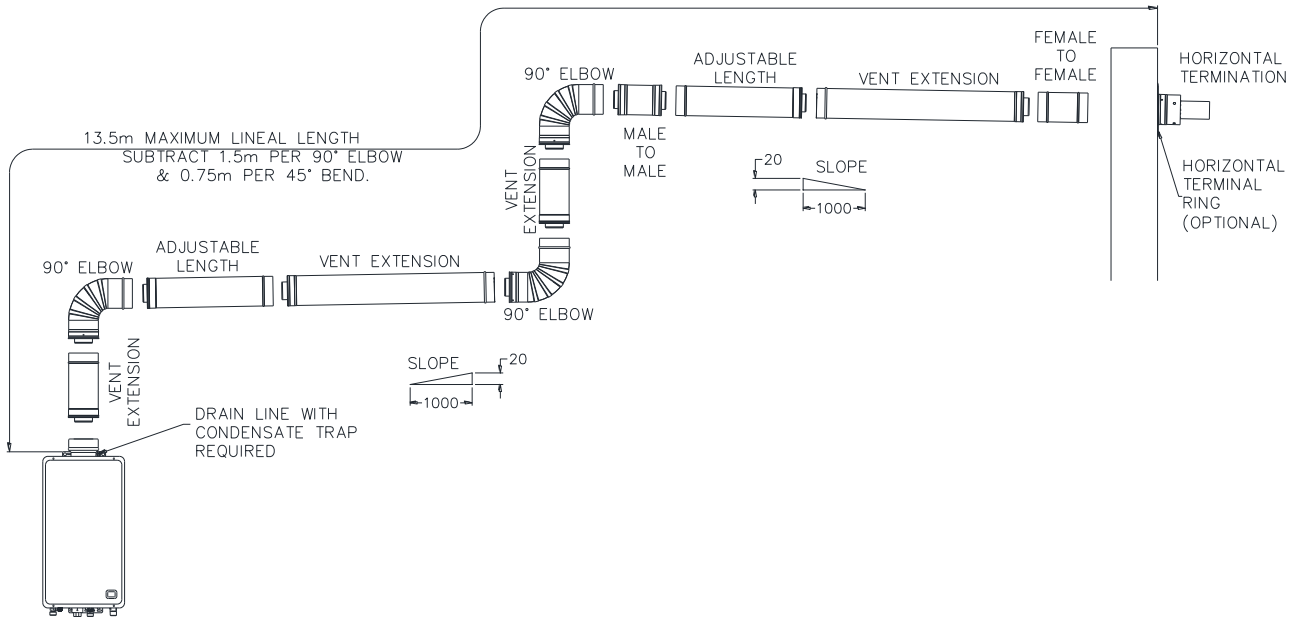
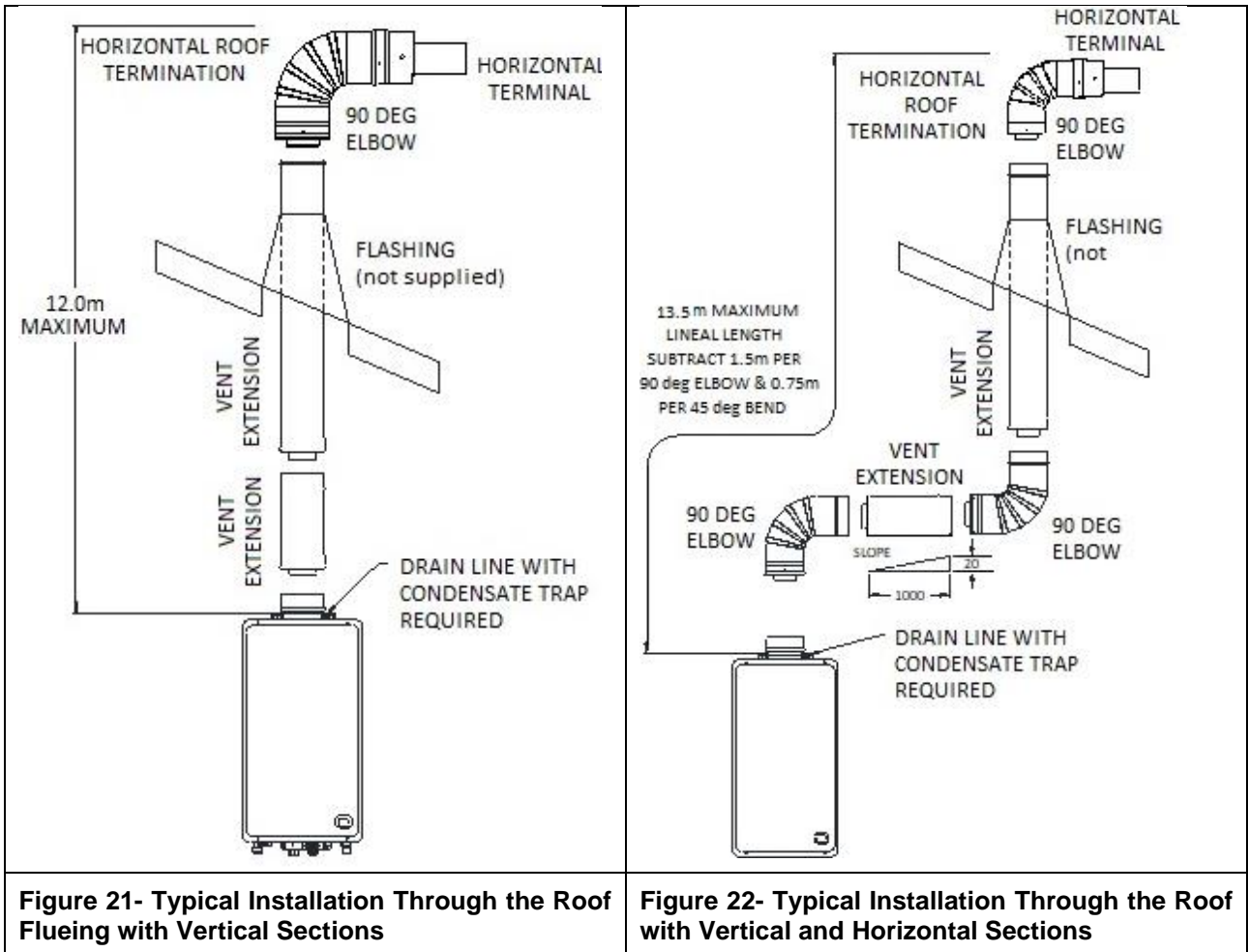

Figure 20- Typical Installation Horizontal Terminal with Multiple Vertical and Horizontal Sections



HORIZONTAL FLUE INSTALLATION

Horizontal Flueing – Directly Behind Water Heater

This method of flue installation is used where the secondary flue is to penetrate and terminate immediately behind the wall on which the water heater is mounted.

Do not remove the plastic film from the flue outlet of water heater prior to this type of flue installation, to prevent debris from the drilling operation entering the water heater flue outlet.

Notes:

Ensure each flue component is fully engaged and the rubber seal on the inner duct is well seated at each joint.

Each flue component is supplied with screws to connect to the adjacent flue component. The screws are located in a bag taped to the outside of the flue component.

- Carefully remove the template inserted as the middle pages of this installation instructions booklet.
- Align the mounting bracket holes on the template exactly over the upper wall mounting bracket holes on the water heater.

This step presumes the water heater is hung on the wall. For floor mounted units, align the template as close as possible with the upper mounting bracket holes on the water heater.

- It may be convenient to tape the template to the wall.

Note: Ensure there are no studs, noggins, pipes or electrical cables located in the wall where the flue is to penetrate

- Mark the pilot hole location through the centre of the template.
 - Remove but **DO NOT DISCARD** the template, repeat for each water heater.
- Drill a pilot hole using a 6.5 mm diameter or smaller drill bit.

The drill bit must be long enough to penetrate completely through the outer skin of the external wall.

Note: Ensure the drill remains level and straight during this step.

- Cut along the middle of the **bold** circle marked “Cut Line” on the template.
- Align the centre of the template with the pilot hole on the wall surface and scribe around the template onto the wall.

The circle should be 150 mm in diameter.

- Remove but **DO NOT DISCARD** the template, repeat for each water heater.

- Align the centre of the template with the pilot hole on the outside wall surface and scribe around the template onto the wall.

The circle should be 150 mm in diameter.

- Remove the template.

- Drill or cut the flue termination hole through the wall using a cutting tool suitable for the wall construction.

Note: The Trim Ring (PN 295125) will cover a 150 mm diameter hole.

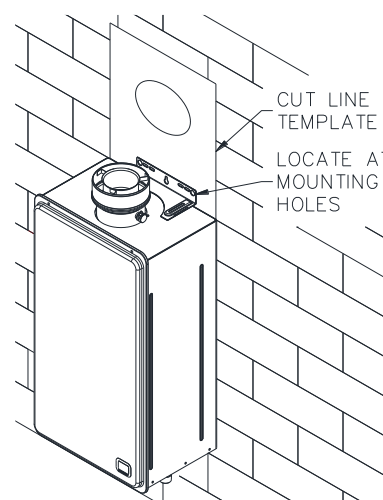

Position template

9. Connect the horizontal terminal (PN295146) and 300mm straight length (PN 295152) into the hole in the wall. Fit a trim ring over the last section of flue.

10. Secure each flue component using the sheet metal screws provided.

11. Connect the 90° Elbow (PN 295147) to the water heater flue outlet so it is orientated behind the water heater.

- > Fit the end of the elbow down over the water heater flue outlet as far as it will go.

Ensure there is a minimum 35 mm and maximum 42 mm overlap, the rubber seal on the inner flue is well seated and the elbow is fully engaged on the water heater flue outlet.

- > Secure the elbow to the outlet with the screws provided.

Note: A total wall thickness of greater than 170 mm will require a 300 mm Straight Length of flue.

12. Fit the Horizontal Terminal assembly to the 90° Elbow and secure using the sheet metal screws provided.

13. Adjust the mounting brackets at the top and bottom of the water heater if required. Bracket adjustment of up to 30 mm can be made and may assist with flue fitment and alignment.

14. Check the end of the outer skin of the flue terminal extends a minimum of 75 mm from the face of the external wall.

15. Apply an adequate bead of sealant around the flue assembly and exterior wall of the building, using a general purpose silicone sealant suitable for outdoor application.

Failure to properly seal the flue penetration through the wall will result in long term damage due to weather conditions.

16. Apply an adequate bead of sealant on the rear face of a Trim Ring, using a general purpose silicone sealant suitable for outdoor application.

- > Fit the Trim Ring over the flue terminal and press against the wall.

17. Apply an adequate bead of sealant around the flue assembly and interior wall of the building and on the rear face of the Trim Ring, using a general purpose silicone sealant suitable for indoor application.

Press the Trim Ring against the wall.

Refer to [“Connections – Electrical”](#) on [page 61](#) electrical connection details and [“Commissioning”](#) on [page 64](#) for the commissioning details of the water heater.

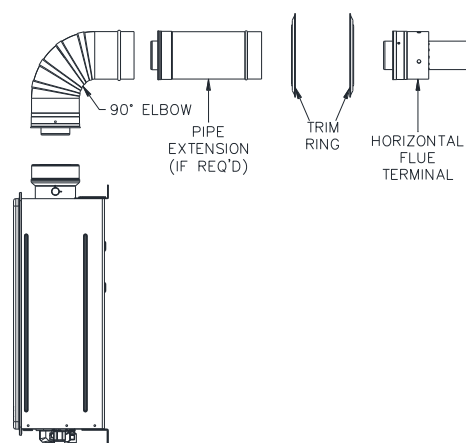

flue components required

SECURE HORIZONTAL TERMINATION TO VENT USING SHEET METAL SCREWS PROVIDED

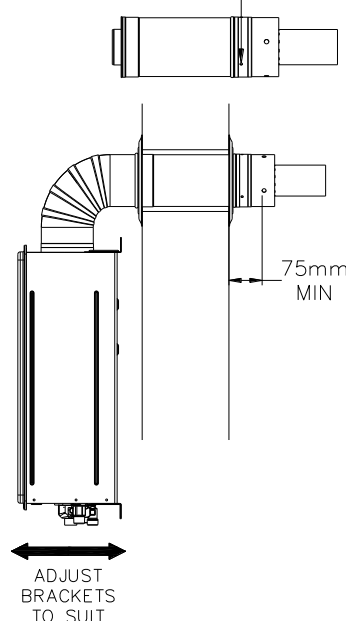

Horizontal Flueing – Extended Flue Run

Notes:

- Ensure each flue component is fully engaged and the rubber seal on the inner duct is well seated at each joint.
- Each flue component is supplied with screws to connect to the adjacent flue component. The screws are located in a bag taped to the outside of the flue component.
- Refer to diagrams:
 - “Typical Installation – Horizontal Terminal with One Elbow” on [page 49](#), and
 - “Typical Installation – Horizontal Terminal with Multiple Vertical and Horizontal Sections” on [page 50](#).

To install an extended horizontal flue and termination:

1. Install the water heater in its final location.
2. Connect the 90° Elbow (PN 295147) to the water heater flue outlet and rotate in the desired direction of discharge, if the flue is not to have a change of direction from horizontal to vertical.
 - Fit the end of the elbow down over the water heater flue outlet as far as it will go.
Ensure there is a minimum 35 mm and maximum 42 mm overlap, the rubber seal on the inner flue is well seated and the elbow is fully engaged on the water heater flue outlet.
 - Secure the elbow to the outlet with the screws provided.
3. Mark the location where the top of the flue is to penetrate the wall to outside of the building.

If the flue is not to have a change of direction from horizontal to vertical, then to accurately mark this position:

- Measure the vertical distance from the floor to the top of the 90° Elbow, and
- Measure the horizontal distance from the wall behind the water heater to the centre of the 90° Elbow, and
- Then, where the flue is expected to penetrate the wall, mark the vertical distance up from the floor and the horizontal distance out from the wall measured from the previous steps.

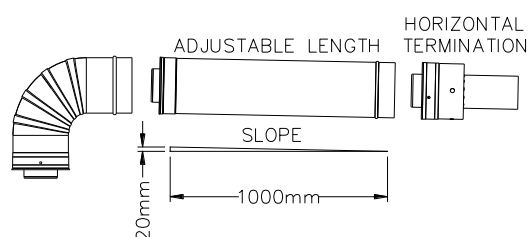

Note: If the flue is to have an additional one or two horizontal changes of direction, then it is not necessary to measure or mark the horizontal distance from the wall behind the water heater to the centre of the 90° Elbow.

- Alternatively, using a level, run from the top of the 90° Elbow to a location horizontal on the wall where the flue will penetrate and mark this point on the wall
- Measure the horizontal distance, along the proposed flue route, from the end of the 90° Elbow to the where the flue is to penetrate the wall.

Divide this measurement by 50 to calculate the vertical distance fall of the flue (allowing for a 1 in 50 fall).

- Measure this distance down from the previous mark placed on the wall.

This point will be the top of the flue termination hole and the flue will have a gradient of 20 mm per metre of length towards the terminal.

Note: Ensure there are no studs, noggins, pipes or electrical cables located in the wall where the flue is to penetrate

4. Carefully remove the template inserted as the middle pages of this installation instructions booklet.
 - > Cut along the middle of the **bold** circle marked “Cut Line”.
5. Align the top of the circular template with the mark on the wall.
 - > It may be convenient to tape the template to the wall.
6. Mark the pilot hole through the centre of the template and scribe around the template onto the wall.

The scribed circle should be 150 mm in diameter.

 - > Remove but **DO NOT DISCARD** the template, repeat for each water heater.
7. Drill a pilot hole using a 6.5 mm diameter or smaller drill bit.

The drill bit must be long enough to penetrate completely through the outer skin of the external wall.

Note: Ensure the drill remains level and straight during this step.
8. Align the centre of the template with the pilot hole on the outside wall surface and scribe around the template onto the wall.

The scribed circle should be 150 mm in diameter.

 - > Remove the template.
9. Drill or cut the flue termination hole through the wall using a cutting tool suitable for the wall construction.

Note: The Trim Ring (PN 295125) will cover a 150mm diameter hole.
10. Starting from the 90° Elbow and working towards the terminal location, connect all of the other flue system components.
 - > Ensure each flue component is fully engaged and the rubber seal on the inner duct is well seated at each joint.
11. Secure each flue component using the sheet metal screws provided.
12. Support horizontal sections at a distance no greater than 2 m using a Wall Bracket (PN 295129).
13. A horizontal run of flue connecting directly to a Horizontal Flue Terminal must have a downward gradient to the flue terminal.
 - > Use Male to Male and Female to Female Adapters to reverse the direction of flue insertion where three or more sections of flue are used in a horizontal flue run and the flue drains toward the flue terminal. Refer to the [diagram](#) on **page 49**.

This provides for proper draining of condensate without pooling at the flue component joins.
14. A horizontal run of flue between two elbows, where the elbow closest to the flue terminal is **orientated upward**, must have a gradient upward in the direction of the flue terminal.

Note: Connection to the condensate manifold must be made if the flue has a gradient upward in the direction of the flue terminal. Refer to **step 22**.
15. The Adjustable Straight Length (PN 295153) may be required if a special length is required between offsets or changes in direction of the flue or to ensure the outer skin of the Horizontal Flue Terminal extends a minimum of 75 mm from the face of the external wall.
 - > The Adjustable Straight Length can be adjusted from 560 mm to 890 mm by pulling on its end to increase its length or pushing on its end to decrease its length.
16. Fit a Trim Ring over the last section of flue prior to penetrating the wall.

SECURE SECTIONS OF
FLUE USING SHEET METAL
SCREWS PROVIDED

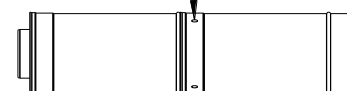

17. Once the flue is assembled and penetrating the wall, install the Horizontal Terminal and secure the termination to the flue using the sheet metal screws provided.

Note: If the flue terminal position is more than 1800 mm above a safe working surface, then suitable equipment will be required to enable safe access to fit the flue terminal.

Alternatively, the flue terminal may be fitted to the flue assembly prior to the assembly penetrating the wall.

18. Make a final adjustment to the Adjustable Straight Length, if required, to ensure the end of the outer skin of the flue terminal extends a minimum of 75 mm from the face of the external wall.

> Firmly tighten the compression band on the Adjustable Straight Length to prevent the pipe from extending or compressing its length over time.

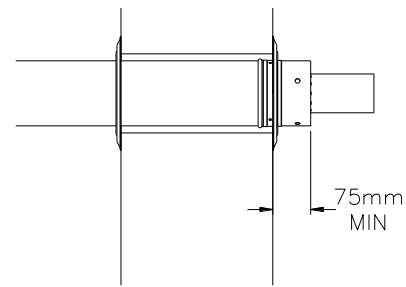

19. Apply an adequate bead of sealant around the flue assembly and exterior wall of the building, using a general purpose silicone sealant suitable for outdoor application.

Failure to properly seal the flue penetration through the wall will result in long term damage due to weather conditions.

20. Apply an adequate bead of sealant on the rear face of a Trim Ring, using a general purpose silicone sealant suitable for outdoor application.

> Fit the Trim Ring over the flue terminal and press against the wall.

21. Apply an adequate bead of sealant around the flue assembly and interior wall of the building and on the rear face of the Trim Ring, using a general purpose silicone sealant suitable for indoor application.

Press the Trim Ring against the wall.

22. Connect the condensate drain spigot on the water heater flue outlet to the condensate manifold if the flue has a change of direction from horizontal to vertical or if there is a long vertical rise directly from the water heater.

Refer to [“Draining the Condensate”](#) on [page 47](#) and to Figure 18- Condensate Trap and Condensate Drain Line on [page 48](#).

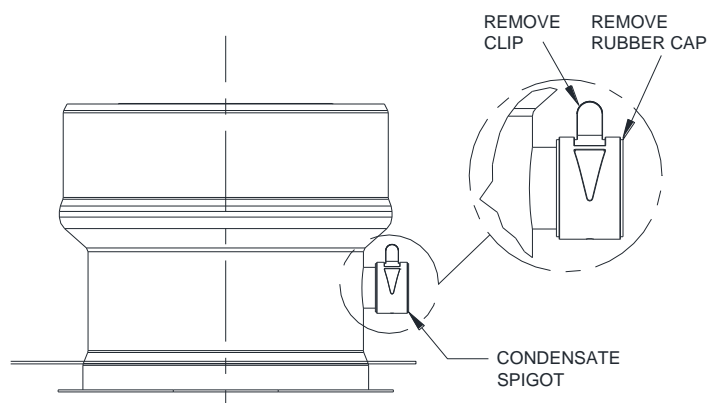

Condensate drain spigot

Refer to [“Connections – Electrical”](#) on [page 61](#) electrical connection details and [“Commissioning”](#) on [page 64](#) for the commissioning details of the water heater.

Through the Roof Installation

Suitable flashing (not supplied) is required to waterproof the roof penetration.

Notes:

- Ensure each flue component is fully engaged and the rubber seal on the inner duct is well seated at each joint.
- Each flue component is supplied with screws to connect to the adjacent flue component. The screws are located in a bag taped to the outside of the flue component.
- Refer to diagrams:
 - “Typical Installation – Through the Roof Flueing” on [page 50](#), and
 - “Typical Installation – Through the Roof Flueing with Vertical and Horizontal Sections” on [page 50](#).

To install a vertical flue and termination:

1. Determine the location where the flue will penetrate through the roof.

Note: Ensure there are no rafters, purlins, pipes or electrical cables located in the roof where the flue is to penetrate.

2. Drill or cut the flue termination holes through the roof and ceiling of a suitable size to allow the installation of the flue, using a cutting tool suitable for the roof construction.
3. Connect the condensate drain spigot on the water heater flue outlet to the condensate manifold assembly.

Refer to “Draining the Condensate” on [page 47](#) and to [Figure 18- Condensate Trap and Condensate Drain Line](#) on [page 48](#).

4. Connect the first flue component to the water heater flue outlet.

- Fit the end of the flue component down over the water heater flue outlet as far as it will go.

Ensure there is a minimum 35 mm and maximum 42 mm overlap, the rubber seal on the inner flue is well seated and the flue component is fully engaged on the water heater flue outlet.

- Secure the elbow to the outlet with the screws provided.

5. Continuing from the first flue component and working towards the terminal location, connect all of the other flue system components.

- Ensure each flue component is fully engaged and the rubber seal on the inner duct is well seated at each joint.

6. Horizontal flue runs between elbows must have a minimum upward gradient towards the flue terminal of 20 mm per metre.

Note: Ensure that the seam of the inner flue in horizontal runs is towards the top of the installation.

7. Secure each flue component using the sheet metal screws provided.

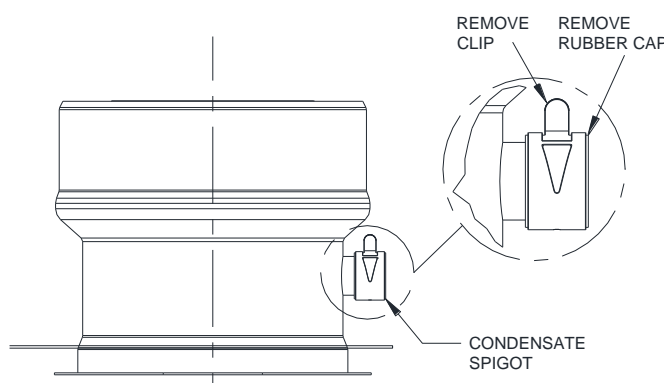

Condensate Drain Spigot

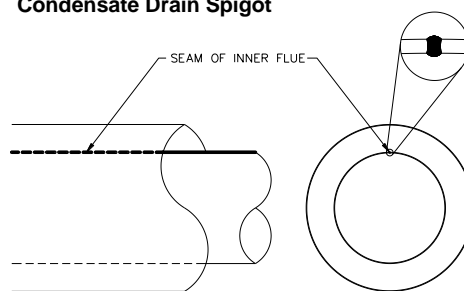

SECURE SECTIONS OF FLUE USING SHEET METAL SCREWS PROVIDED

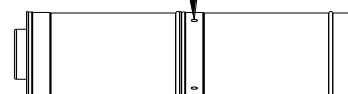

8. Fix a Wall Bracket after each transition to a vertical run.

This is to prevent vertical loading on the elbows and offsets.

9. Support vertical sections of flue at a distance no greater than 2 m using a Wall Bracket (PN 295128).

Note: The Wall Bracket can be used to support vertical sections of flue from a ceiling by rotating the legs through 90°.

10. Install an Adjustable Straight Length (PN 295153) if a special length is required between offsets or changes in direction of the flue.
- > The Adjustable Straight Length can be adjusted from 560 mm to 890 mm by pulling on its end to increase its length or pushing on its end to decrease its length.
 - > Firmly tighten the compression band on the Adjustable Straight Length to prevent the pipe from extending or compressing its length over time.

11. Fit a Trim Ring over the last section of flue prior to penetrating the ceiling, if one is to be fitted.

12. Once all flue components, excluding the 90 degree bend and Horizontal Terminal, have been installed and all supports are securely fastened, the roof flashing must be installed and adequately sealed to prevent rain entry.

- > Cut the flashing to a diameter that allows a snug fit over the flue.
- > Install the roof flashing over the flue and using suitable fasteners, fix to the roof material.

The flue must extend a minimum of 150 mm through the roof flashing.

13. Connect the 90 Degree Bend (PN 295147) and Horizontal Terminal (PN 295146) to the flue exiting the roof.

- > Secure the joint with sheet metal screws provided.

The bottom of the Horizontal Terminal should not be less than 450 mm above the flashing below.

Observe flue terminal clearances in accordance with AS/NZS 5601.1. Refer also to [“Flueing Through the Roof”](#) on [page 46](#).

Note: The flue should not extend more than 1.5 m from the roof unless guy wires or other additional support is provided.

14. Apply an adequate bead of sealant around the flue assembly and flashing and around the flashing and roof material, using a general purpose silicone sealant suitable for outdoor application.

Failure to properly seal the flue penetration through the roof will result in long term damage due to weather conditions.

15. Apply an adequate bead of sealant around the flue assembly and ceiling and on the rear face of the Trim Ring (if fitted), using a general purpose silicone sealant suitable for indoor application.

Press the Trim Ring (if fitted) up against the ceiling.

16. Upon completion of the secondary flue installation, remove the warning label adhered to the top left hand corner of the water heater’s front panel.

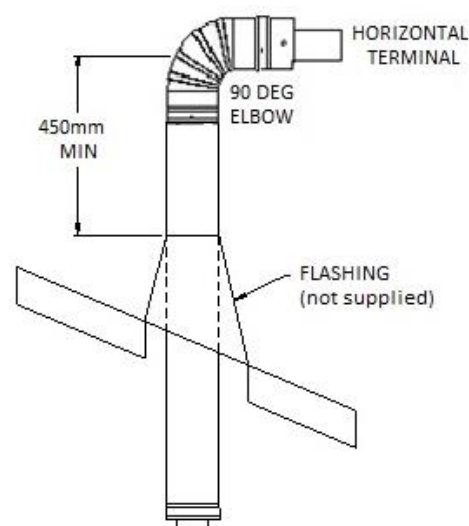
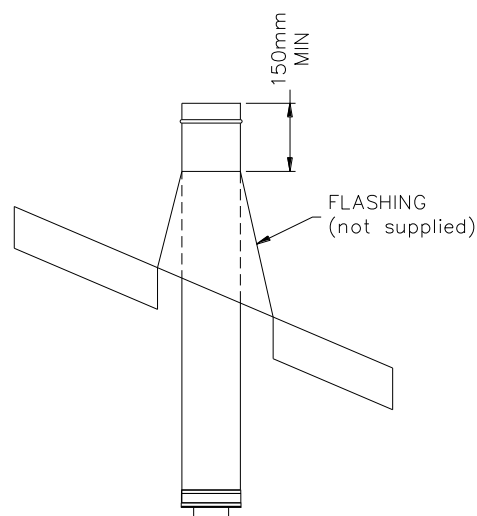

Refer to [“Connections – Electrical”](#) on [page 61](#) electrical connection details and [“Commissioning”](#) on [page 64](#) for the commissioning details of the water heater.

MULTIPLE WATER HEATER FLUE INSTALLATION

Where multiple water heaters are installed, each water heater must be individually flued to the outside. A common flue system **MUST NOT** be used.

For a multiple unit installation, the water heater is certified for installation with zero clearance between adjacent water heaters.

If multiple water heaters are mounted on a wall it is necessary to leave a suitable space of 20 mm between each water heater if condensate manifold assembly is to be installed.

Refer to “[Flue Terminal Location](#)” on [page 46](#) for flue terminal clearances from other objects in accordance with AS/NZS 5601.1.

Follow the relevant instructions pertaining to the type of flue installation, with the following additional requirements in relation to flue terminal clearances to be taken into account. The distances are based on using the coaxial flue system components.

Note: All flues for multiple water heaters **MUST** terminate horizontally.

Flueing through the Wall

1. The minimum **horizontal** centre to centre distance between flue terminals is to be no less than 360 mm.
2. The minimum **vertical** centre to centre distance between flue terminals is to be no less than 570 mm.

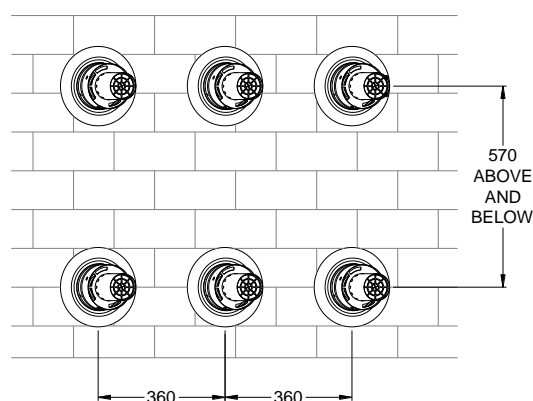

Flueing through the Wall

Flueing through the Roof

The minimum **side by side** centre to centre distance between flue terminals is to be no less than 360 mm.

1. Run the flueing through the roof as dictated by plant room requirements.
2. Each flue is to be terminated horizontally by using 90 degree elbows (PN 295147) and horizontal flue terminals (PN 295146).
3. The flue terminals for back to back water heaters should be installed 180 degree opposite to each other as shown.

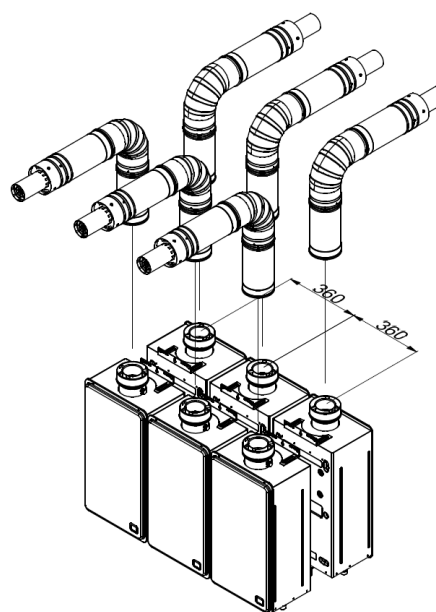

Flueing through the Roof

MULTIPLE WATER HEATER CONDENSATE TRAP AND CONDENSATE DRAIN LINE INSTALLATION

Depending upon the type of installation, it may be necessary to install a condensate trap and condensate drain line to each water heater. Refer to “[Draining the Condensate](#)” on [page 47](#).

The drain line from each condensate trap may be:

- Drained separately to a discharge point, or
- Manifoldeed together with a single drain line running to a discharge point.

If discharged separately, a condensate trap must be installed and filled with water in each water heater drain line prior to the discharge point.

CONDENSATE MANIFOLDED ASSEMBLY

If discharged from a manifolded drain line, follow below steps to install a condensate trap kit (P/N AS33121006) and condensate tube kit (P/N AS3312007):

1. Identify the number of condensate tube kits required (AS3312007). One (1) condensate tube kit is required for each CFWH.
2. One (1) condensate trap kit is required (AS3312006) per a condensate manifold. Back to back systems require a manifold for each side and therefore 2 trap kits will be required.
4. Install the CFWHs with 363mm pitch (or 20mm spacing between adjacent CFWH).
5. Remove the clamp and rubber cap from the condensate drain spigot on the water heater flue outlet. Ensure that each spigot is facing towards the right-hand side when facing the CFWH front cover. Discard the clamp and the rubber cap.
6. Fit the long silicone tube and aluminium tube included in the condensate tube kit between the CFWHs. Ensure the silicone tube is not kinked, twisted or pinched and ensure it is not caught on any CFWH exterior surfaces.
7. Fit the end of the short silicone tube to the spigot of the water heater flue outlet.
8. Cut the polyethylene tube included in the condensate tube kit to 348mm.
9. Connect plastic tubes and plastic fittings to create a plastic tube manifold.
 - Use a 90° elbow on the leftmost fitting, provided with the condensate trap kit.
 - Use the tee fitting provided with a condensate tube kit to connect two polyethylene tubes together. The unused connection on the tee fitting should point upwards.
 - Use the tee fitting provided with a condensate tube kit as the rightmost fitting. The unused connections on the tee should point vertically.
10. Connect the condensate trap assembly to the rightmost tee fitting connection facing downwards.
11. Secure each polyethylene tube connections with the plastic ratchet clamps provided with condensate tube kits.
12. Connect each long silicone tube to the upward facing tee fitting connections. Ensure the silicone tube is not kinked, twisted or pinched.
13. Affix the condensate trap retaining bracket to the wall provided with the condensate trap kit using suitable anchors.
14. Affix the condensate manifold to the wall. P-clips are provided with condensate tube kits.
15. Direct the outlet of the condensate trap to suitable drain. Two plastic elbows are provided to direct the outlet to a convenient position. The last tube section at the end of the condensate trap assembly may be cut shorter, however any other section of the trap assembly must not be tampered.
16. Fill the trap with water from the short silicone tube on the rightmost condensate elbow assembly. Observe that water freely discharges from the outlet of the condensate trap. Fit the short silicone tube back on the CFWH flue spigot.



Warning: Failure to fill with water may cause flue gasses to escape through the condensate trap. The condensate trap should be regularly checked to ensure it is filled with water, replenishing when required.

Notes:

AS/NZS 3500.4 section 5.12 is used as a guide in preparing the following drainage recommendations.

- As the condensate is mildly acidic, copper tube and fittings must not be used as they will corrode.
- Use UPVC (Unplasticised Polyvinyl Chloride) or PE (polyethylene) piping.
- The outlet of the drain line must be in such a position that flow can be easily seen, but arranged so that discharge will not cause injury, damage or nuisance.
- The drain line must not discharge onto electrical connections, earth stakes, copper pipe, concrete paths or into a pond.

CONNECTIONS – ELECTRICAL

All electrical work and permanent wiring must be carried out by a qualified person and in accordance with the Wiring Rules AS/NZS 3000 and all local codes and regulatory authority requirements.

The water heater will only operate on a sine wave of 50 Hz. Devices generating a square wave cannot be used to supply power to the water heater.

POWER OUTLETS

All Tankpak Series 3 systems are factory fitted with power outlets (GPOs) for each CFWH. The power to the GPOs is supplied via the junction box.

INDEPENDENT POWER SUPPLY

Wiring must conform to AS/NZS 3000 including the installation of an appropriately sized B curve type circuit breaker. Consideration must be given to other devices supplied by the same circuit.

SYSTEM POWER SUPPLY

A 1.8m long 10 Amp plug and lead is supplied on certain Tankpak Series 3 models which may be connected to a 10 amp general purpose outlet. The plug and lead is fitted to the junction box. Refer to the table below for the list of models supplied with a plug and lead or requiring hard wiring by a qualified person.

Controller	Plug & lead (10 A)	Hardwire (by installer)
Standard	All	Nil
Deluxe	2 to 4 CFWHs with nil, 2 x UPM3 or 2 x UPMXL secondary pumps With 1 or 2 primary pumps	(i) 2 to 4 CFWHs with 2 x CM3-2 secondary pumps; (ii) 5 to 18 CFWHs with nil secondary pumps (iii) 5 to 18 CFWHs with 2 x UPM3 or 2 x UPMXL or CM3-2 secondary pumps With 1 or 2 primary pumps

Systems not fitted with a plug and lead must be hard wired to a 240V AC 50 Hz M.E.N. (multiple earthed neutral) mains power supply with an all pole isolating switch installed adjacent to and accessible from the water heater (refer to AS/NZS 5601.1:2010 clause 6.2.8). A suitable warning label must be affixed to the water heater if there are additional control circuits not isolated by this switch. This label should direct the service person to the isolation switch for that circuit. Connect power to the vacant terminals located inside the junction box. Circuit size will depend on the purchased system. Note that any external circuit protection must allow for pump inrush current.

Earthing requirements including equipotential bonding to be in accordance with AS/NZS 3000 2018 SECTION 5 - EARTHING ARRANGEMENTS AND EARTHING CONDUCTORS.

BUILDING MANAGEMENT SYSTEM

Tankpak Series 3 Deluxe models can be connected to a High Level Interface BMS system with the inclusion of a Rheem Connect Gateway.

The Rheem Connect Gateway can also provide high level communications to customer external sites or Monitoring by Rheem using either ethernet or 4G modem.

The Rheem Connect Gateway can aggregate data input from Tankpak, Rheem Guardian Warm Water and Rediset Deluxe building circulators for total system integration in one package.

Contact Rheem for further information regarding BMS or remote monitoring options.

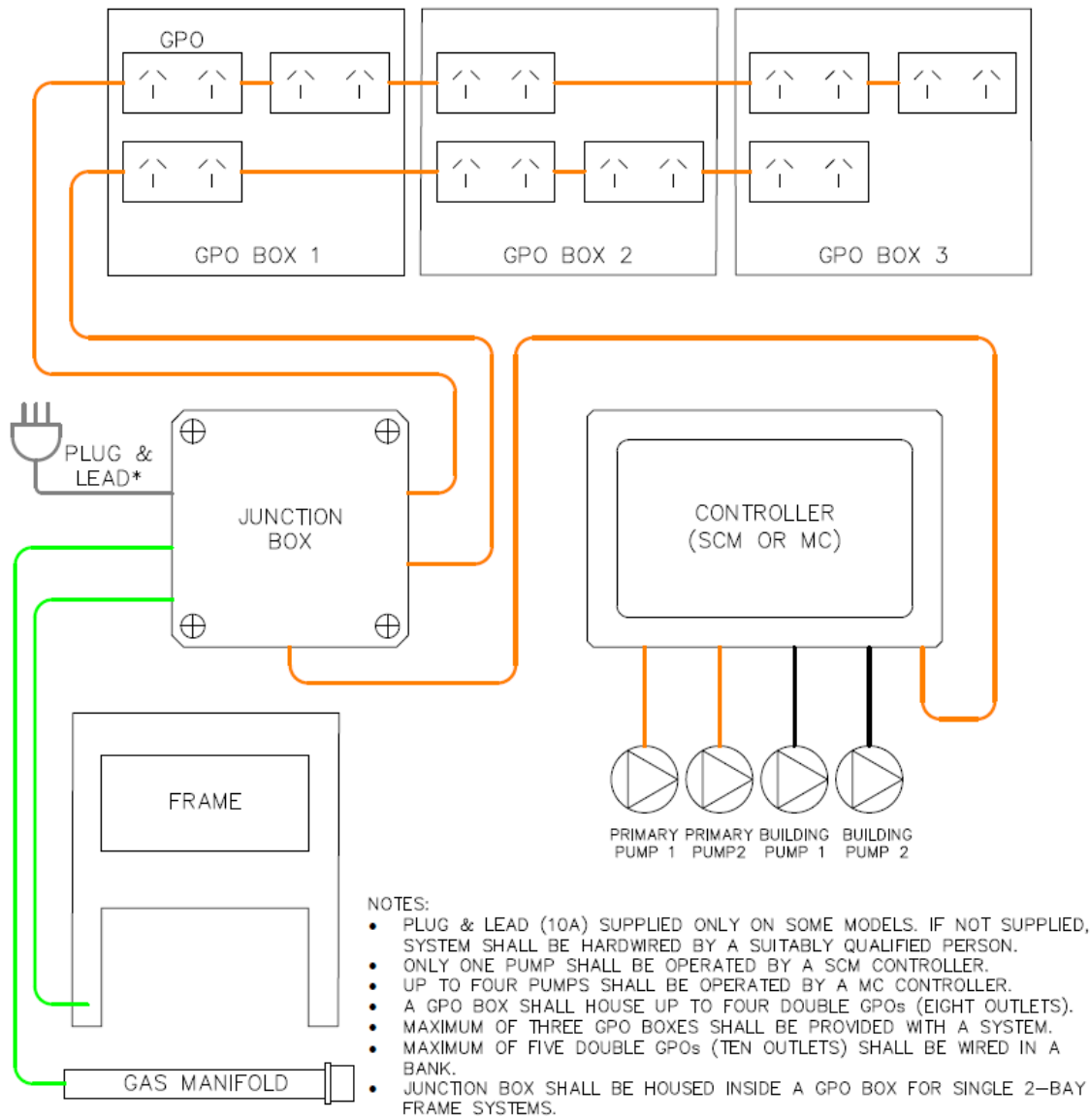

Wiring Diagram – Tankpak Series 3 System Wiring Schematic

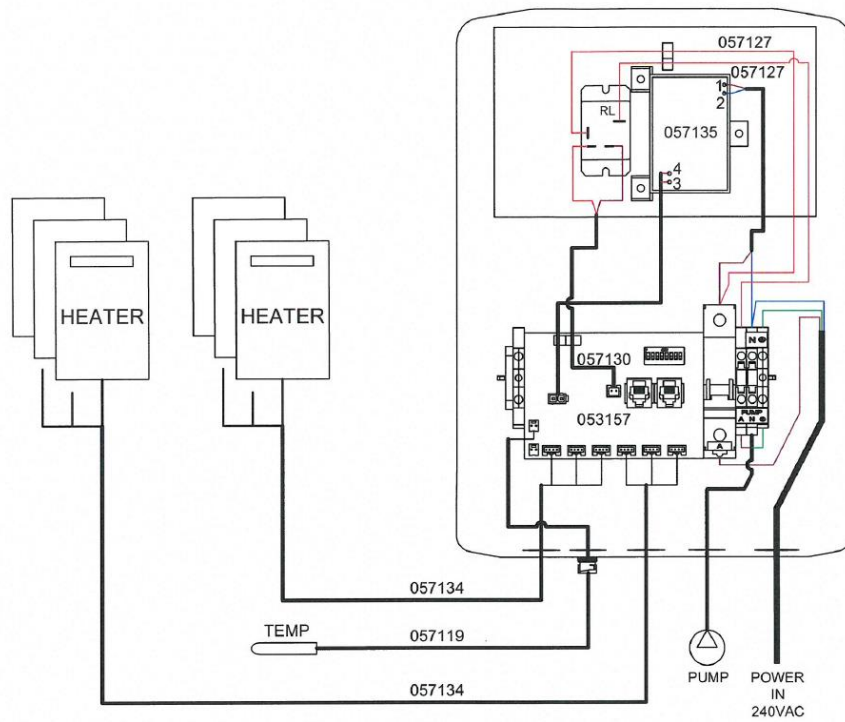

Wiring Diagram – Tankpak Standard Controller

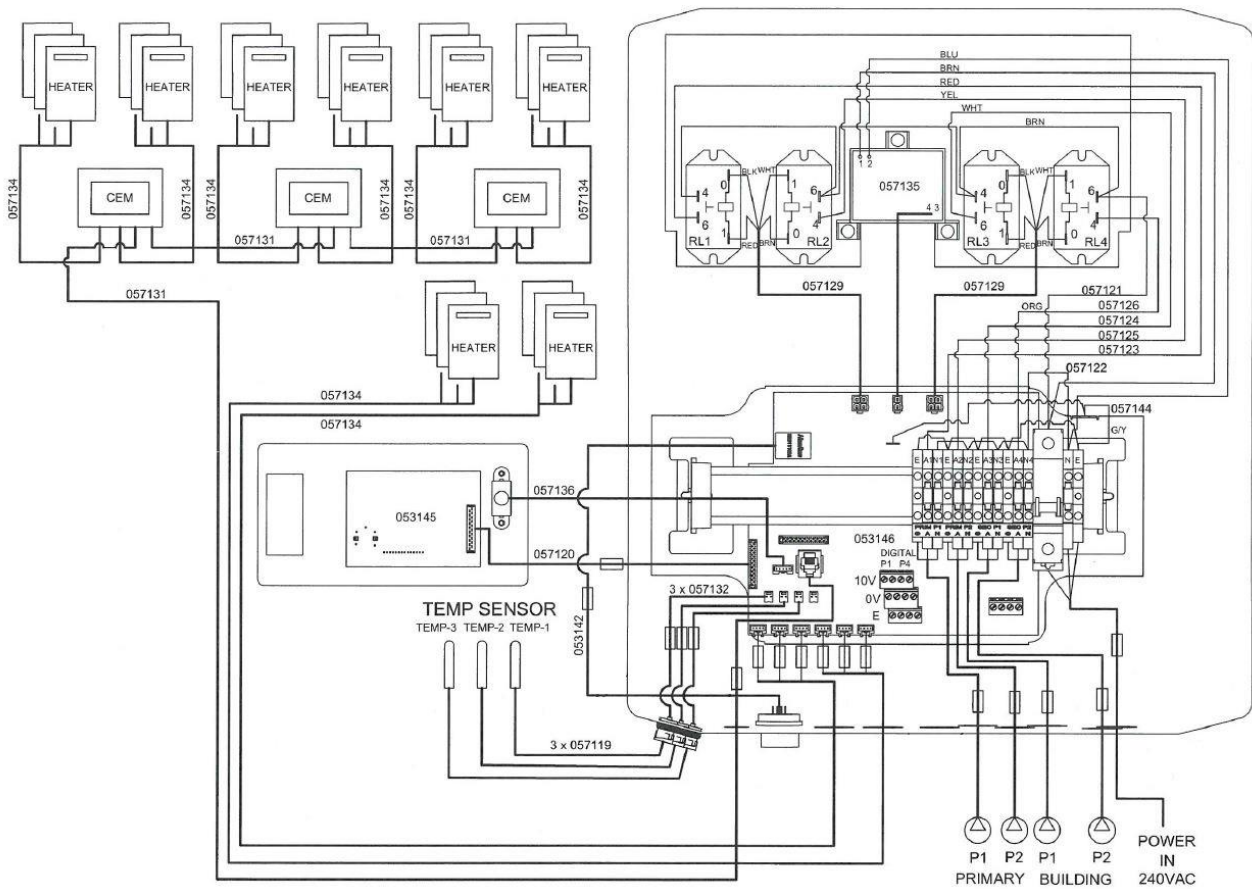

Wiring Diagram – Tankpak Deluxe Controller

COMMISSIONING

INITIAL CHECKS

1. Check that the power supply to the system is switched OFF.
2. Check that an adequate water supply is available to the hot water system.
Water supply pressure shall not exceed the maximum as stated in the instructions supplied with the storage tank.
3. OPEN cold water inlet valve, hot water outlet valve
Check all individual water heater isolation valves are OPEN;
4. Check that the system is fully charged, all the air is bled from the system and no leaks are evident.
5. Check the pipe work for leaks
6. OPEN all individual water heater gas isolation valves and purge gas lines.
7. Check the gas pipe work for leaks

To complete the installation, it is necessary to check the gas supply pressure at the inlet to the water heater, the minimum test point pressure and the maximum test point pressure (refer to “[Gas Inlet Pressure](#)” on [page 65](#)).



Warning: Upon completion of the installation and commissioning of the water heater, leave this guide with a responsible officer. **DO NOT** leave this guide inside of the cover of the water heater, as it may interfere with the safe operation of the water heater or ignite when the water heater is turned on.

STARTING THE SYSTEM

1. Turn on the power at the main isolation switch.
2. On the Tankpak controller, switch the circuit breaker to ON.
 - a. On a Standard Tankpak, the Green LED will flash at 200ms intervals for approximately 1 minute as it performs initialisation procedures.
 - b. On a Deluxe Tankpak, the LCD display will advise “initialising...” for approximately 1 minute as it performs initialisation procedures.
3. At the end of the initialisation period, assuming the tank temperature is below set point, the primary pump will be energised and the CFWH will sequentially start up.
4. If secondary circulators have been supplied as part of a Deluxe Tankpak system, the controller will lock out the secondary circulators until the tank reaches within 4°C of the tank set point. This is to speed up heating of the tank to enable faster total building hot water commissioning.
5. The secondary circulator will initialise and circulate hot water throughout the building.
6. When the building return sensor and tank sensor reach their respective set points, pumps will be de-energised and the CFWH will turn off.
7. The system is up to temperature and ready for use.

GAS INLET PRESSURE

IMPORTANT - CHECK the gas supply pressure at the inlet to the water heater with the water heater and all other gas burning appliances in the premises operating (burners alight). The minimum gas supply pressure range is:

	Natural Gas	Propane/ULPG
Minimum	1.13 kPa	2.75 kPa
Maximum	3.5 kPa	3.5 kPa

If this minimum cannot be achieved, it may indicate the meter or the gas line to the water heater is undersized. It is important to ensure that an adequate gas supply pressure is available to the water heater when other gas burning appliances, on the same gas supply, are operating.

GAS INLET TEST POINT PRESSURE

To check the gas inlet pressure, select the CFWH at the furthest point in the manifold as the test unit:

1. Ensure the burners are not operating, by turning off the power to the Tankpak or CFWH.
2. Close the gas isolation valve at the gas inlet to the CFWH.
3. Locate the gas inlet test point on the gas connection to the CFWH.
 - Remove the test point screw and washer from the test point orifice.
 - Connect the manometer.
4. Open the gas isolation valve fully at the gas inlet to the CFWH.
5. Observe the gas pressure reading on the manometer.

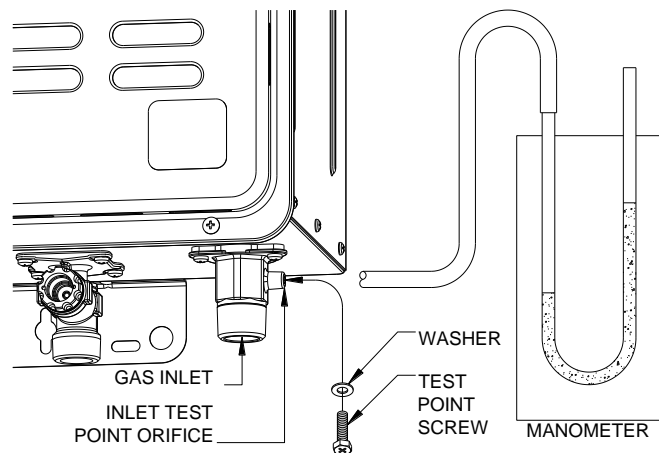

If the manometer reading is between the minimum and maximum inlet gas pressure ratings on the rating label, no adjustment is required.

If the manometer reading is below the minimum inlet gas pressure rating on the rating label, then either the gas pipe to the water heater is undersized and needs to be rectified or adjustment is required at the gas regulator.

If the manometer reading is above the maximum inlet gas pressure ratings on the rating label, then adjustment is required at the gas regulator.

6. Switch on the electrical supply to the Tankpak or CFWH.
7. If the temperature in the tank is below set point, the Tankpak should start automatically.
8. Observe the gas pressure reading on the manometer.

If the manometer reading is between the minimum and maximum inlet gas pressure ratings on the rating label, no adjustment is required.

If the manometer reading is below the minimum inlet gas pressure rating on the rating label, then either the gas pipe to the water heater is undersized and needs to be rectified or adjustment is required at the gas regulator.

If the manometer reading is above the maximum inlet gas pressure ratings on the rating label, then adjustment is required at the gas regulator.

9. If an adjustment was made during Step 8, repeat this procedure from Step 5.
10. Close the isolation valve on the outlet of the CFWH.
11. Close the gas isolation valve at the inlet to the CFWH.
12. Remove the manometer and refit and tighten the test point screw and washer.
13. Open the gas isolation valve fully at the gas inlet to the water heater.
14. Open the isolation valve again so the burners ignite.
15. Test for gas leaks at the test point.



Warning: The removal of the front panel will expose 240 volt wiring. Take care not to touch wiring terminals.

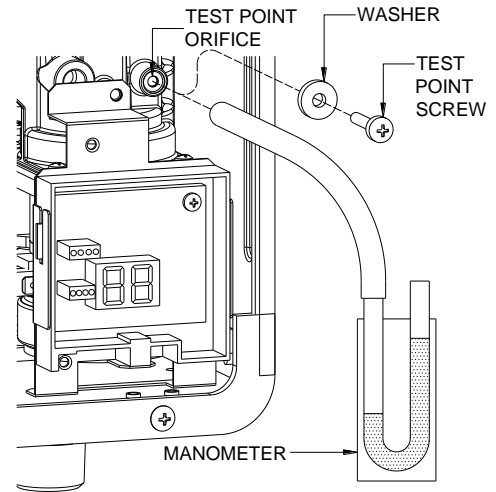

MINIMUM TEST POINT GAS PRESSURE

Refer to the rating label on the water heater for the minimum test point gas pressure.

1. Ensure the burners are not operating, by turning off the power to the CFWH.
2. Remove the screws holding the front panel to the jacket.
3. Gently disengage the front panel and pull forward to remove from the water heater.
4. Locate the burner pressure test point on the main burner manifold.

- Remove the test point screw and washer from the test point orifice.
- Connect the manometer.

5. Switch on the electrical supply at the power outlet to the water heater.
6. Open the gas isolation valve fully at the gas inlet to the water heater, if not already open.

7. Press and hold down the MIN button and observe the reading on the manometer.

- "1L" is shown on the LED display.

8. Release the MIN button. If the manometer reading observed in step 7 agrees with the rating label, no further adjustment is required.

9. To adjust, press and hold the adjuster button.

- "LH" is shown on the LED display.

Note: The adjuster button must be held down continuously through steps 9 to 11.

10. Press and hold the MIN button and observe the reading on the manometer.

- The manometer reading will change as the test point gas pressure adjusts.

Note: While the MIN button is pressed, the gas pressure will at first increase then decrease, cycling between an upper gas pressure limit (39 on the LED display) and a lower gas pressure limit (01 on the LED display).

11. Release the MIN button when the reading on the manometer agrees with the rating label.

12. Release the adjuster button.

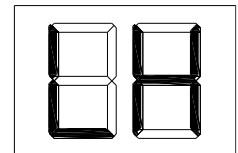
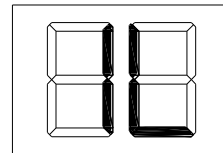
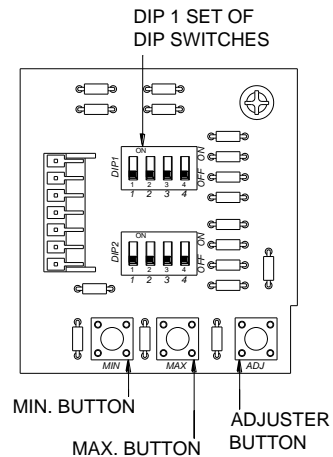

Notes:

- If the burners extinguish and error code 11 or 12 starts to flash on the LED display:
 - release the MIN and adjuster buttons
 - close the CFWH isolation valve
 - clear the error code (refer to “Clearing Error Code” on [page 67](#))
 - recommence the procedure from Step 7
- If the adjuster button is released before Step 11, clear any error code (if displayed) and recommence the procedure from Step 7.

If error code 11 or 12 is experienced on all heaters, the Tankpak system will enter “WAIT” mode for 10 minutes before trying again. This is to allow the installer to purge the gas lines before re-trialling for ignition.

MAXIMUM TEST POINT GAS PRESSURE

Refer to the rating label on the water heater for the maximum test point gas pressure.

Follow Steps 1 to 12 of the “Minimum test point gas pressure” procedure on [page 67](#), but open the hot tap fully and use the MAX button instead of the MIN button. It may be necessary to open two or three hot taps fully, depending upon the model of water heater and the incoming cold water temperature.

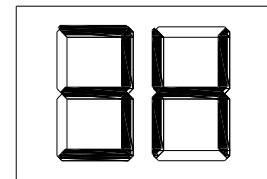

Note: In Step 7, “3H” (027 models) will be shown on the LED display.

After setting the minimum and maximum test point gas pressures:

- Close the outlet isolation valve.
- Remove the manometer and refit and tighten the test point screw and washer.
- Open the isolation valve again so the burners ignite.
- Test for gas leaks.
- Refit the front panel and screws to the water heater.

CLEARING ERROR CODE

If an error code does appear on the LED display during the commissioning process, it will be necessary to clear the error in order to complete the installation.

To clear an error code on the CFWH:

- switch off the electrical supply at the power outlet to the water heater
- check the gas isolation valve at the gas inlet to the water heater is fully open
- wait five (5) minutes
- switch on the electrical supply at the power outlet to the water heater

NOTE: If min/max pressure adjustments were required on the test heater it may be necessary to test all water heaters individually.

PRESET OUTLET TEMPERATURE SETTING

The Tankpak Series 3 controller is factory set to 65°C and the continuous flow water heaters are set to 70°C.

It is usually not necessary to check or adjust the factory preset outlet temperature setting of the water heater, unless the customer or application has a requirement for this to be done.

For applications requiring sanitising temperatures, such as a commercial kitchen, it will be necessary to adjust the preset outlet temperature setting of the controller to achieve and maintain sanitising temperatures up to 82°C. Refer to [page 68](#) for details.

If the water heater is installed as part of a circulated hot water flow and return system in a building, the preset outlet temperature setting must be set to at least 60°C. If the water temperature decreases by more than 5°C through a circulated hot water flow and return system due to heat loss in the ring main, the preset outlet temperature setting of the water heater should be set to at least 65°C.

GAS BOOSTER FOR A SOLAR WATER HEATER

Note: AS 3498 requires that a water heater provides the means to inhibit the growth of Legionella bacteria in potable water. When this water heater is used as an in-series booster for a solar water heater it can satisfy this AS 3498 requirement provided it is energised and the booster preset outlet temperature setting is 70°C or higher.

Note

- Consideration must be given to the delivery temperature to any ablution and public areas such as a bathroom, ensuite or public amenities. Refer to “Hot Water Delivery” on [page 34](#).

MODIFYING THERMOSTAT SETTINGS

Tankpak Series 3 is factory supplied pre-set to maintain a tank temperature set point of 65°C, with a tank differential of 3 °C.

The parameters of the controller and continuous flow water heaters may need to be adjusted to achieve the desired system operating temperature should it differ from the factory setting.

Refer to the table and instructions on [page 68 to 69](#) for instructions on adjusting the temperature setting.

System Operating Temperature (°C)	CFWH Thermostat Setting (°C)	Tank temperature Set Point (°C)	Tank temperature Differential (°C)
60	65	60	3
65	70	65	3
70	75	70	3
75	82	75	3
79	82	79	3

STANDARD CONTROLLER INFORMATION

Standard Tankpak Series 3 models are supplied with a Standalone Controller Module (SCM).

LED INDICATION: The SCM has a Green LED for operation indication (including Running, Idle, Wait Mode) and a Red LED for Error.

- Green LED will flash at 200ms intervals during initialisation, this takes about 50 seconds after SCM is powered up.
- Green LED will flash at different rates according to the table below.

Running Mode (When heaters are firing)	Idle Mode (when heaters are not firing)	Wait Mode (special conditions up to 10 minutes)
2 Sec ON / 2 Sec OFF	4 Sec ON /200ms OFF	GREEN LED Solid ON

- Red LED will flash at different rates according to the table on page 17 (Error Code for Standard Controller).

Standard Controller Module (SCM) parameters are configured via the DIP switches.

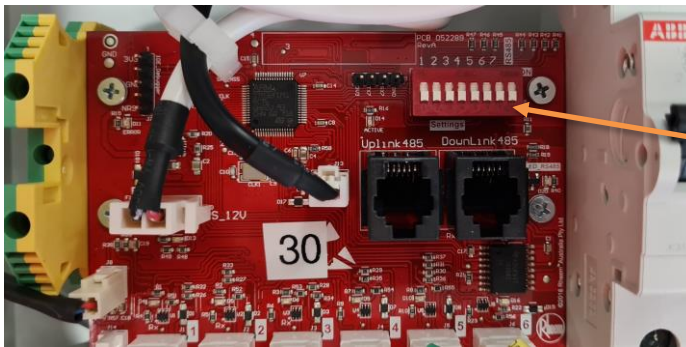

Switch OFF and Isolate Power Supply before removing front cover of the standard controller in order to access the DIP Switches inside.

Tankpak Standard controller is factory set at the values stated below.

- CFGWH set point 70°C
- Tank Bottom set point 65°C
- Tank Bottom Diff 3°C

From factory, Dip Switch Configuration (from DIP switch 1 to 8) is 11011110 (1=ON, 0=OFF)

DIP1	DIP2	DIP3	DIP4	DIP5	DIP6	DIP7	DIP8	
								ON (1)
								OFF (0)

MODIFYING TANKPAK STANDARD CONTROLLER TEMPERATURE SETTINGS

Tankpak Series 3 Standard controller settings can be modified by changing the Dip switch (2-6) settings. All Dip switch settings are:

DIP1*	DIP2	DIP3	DIP4	DIP5	DIP6	DIP7*	DIP8	DIP SWITCH SETTING
MODE	CFGWH TEMPERATURE SET POINT (REFER TO CFGWH SET POINT SETTINGS TABLE BELOW)			DIFF TO CFGWH SETPOINT	DIFF TO DIP5	MODEL	NOT USED	
RECIRC				-5 °C	-3°C	TANKPAK		ON (1)
NA				-3 °C	-5 °C	DO NOT USE		OFF (0)

CFWH set point settings:

DIP 1	DIP 2	DIP 3	DIP 4	SET POINT CFGWH TEMP[°C]
1	0	0	0	60
1	1	0	0	62
1	0	1	0	63
1	1	1	0	65
1	0	0	1	67
1	1	0	1	70
1	0	1	1	75
1	1	1	1	82

*DIP 1 and 7 **MUST BOTH** be set to 1 (ON) for correct system operation

DELUXE CONTROLLER INFORMATION

Deluxe Tankpak Series 3 models are supplied with a Master Controller (MC) and one or two Controller Extension Modules (CEM) for systems with more than 6 CFWH.

The MC features a backlit LCD display and adjustment knob for scrolling through menus and adjusting parameters. Refer to the Display Menu on **pages 71 and 72** for menu navigation and control knob operation and the table on **page 73** for parameter settings.

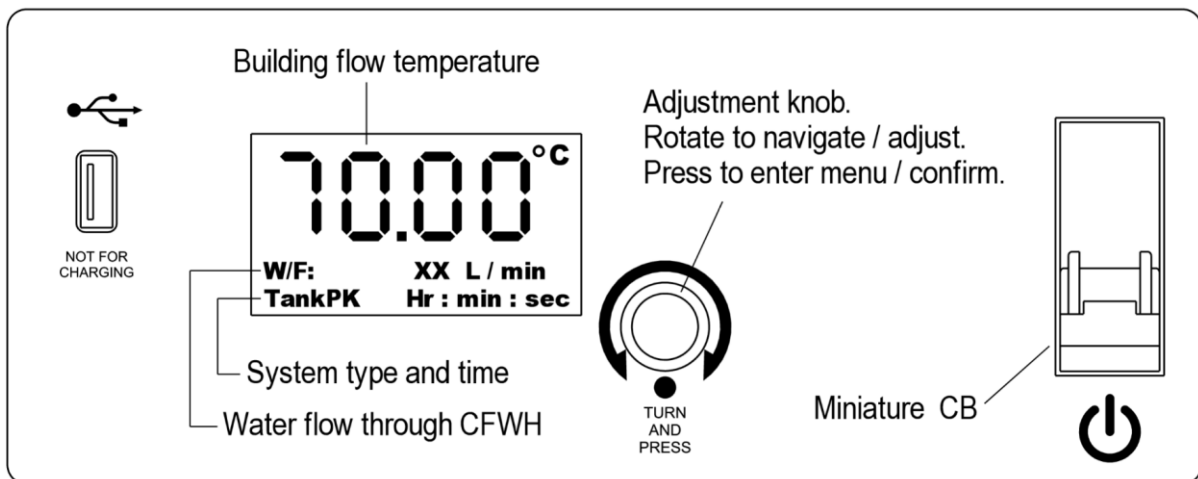

Deluxe Controller Home Screen Display

NOTE: Pressing the adjustment knob once will display Tank Bottom temperature and Building Return temperature on the bottom two rows

DELUXE CONTROLLER DISPLAY MENU

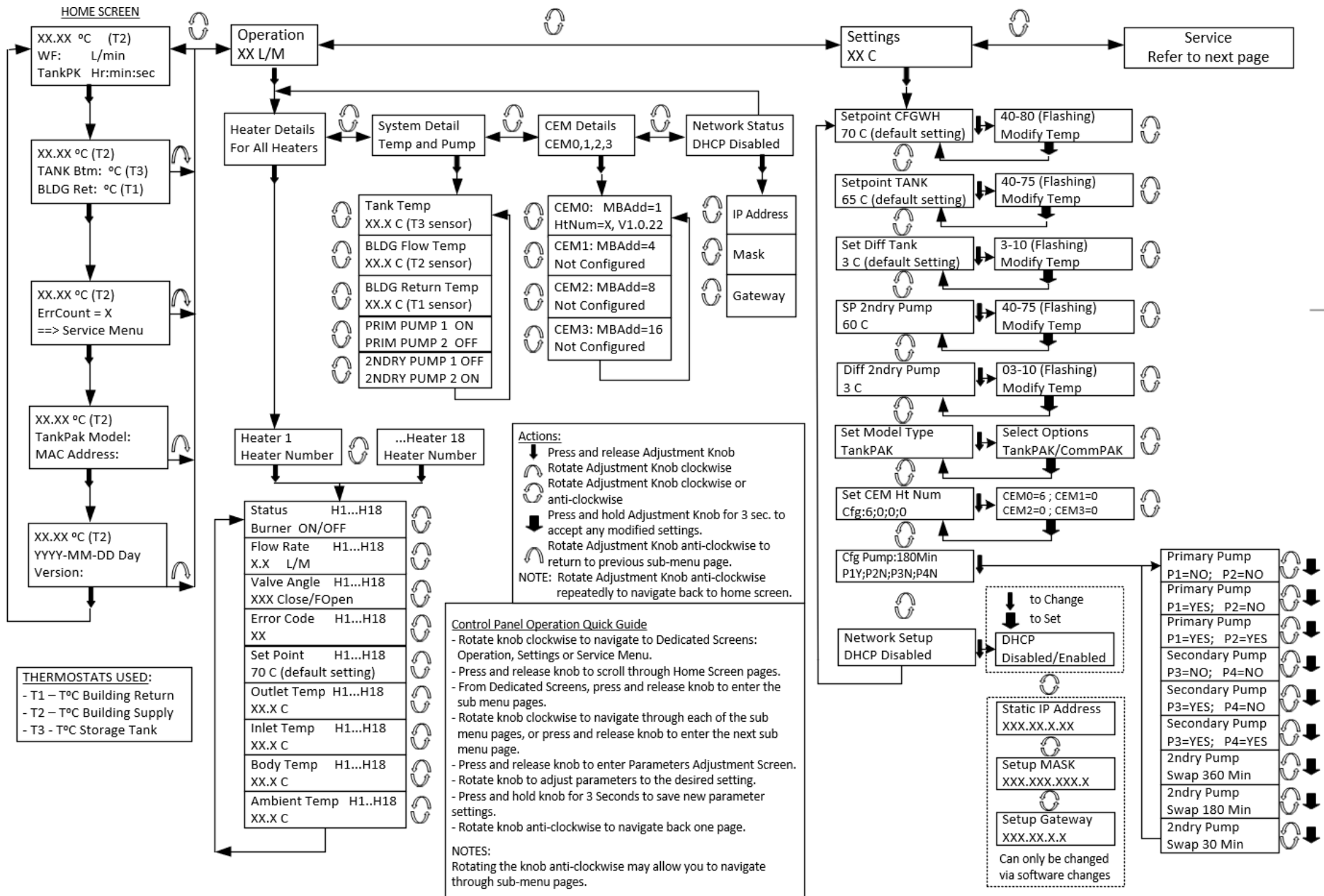

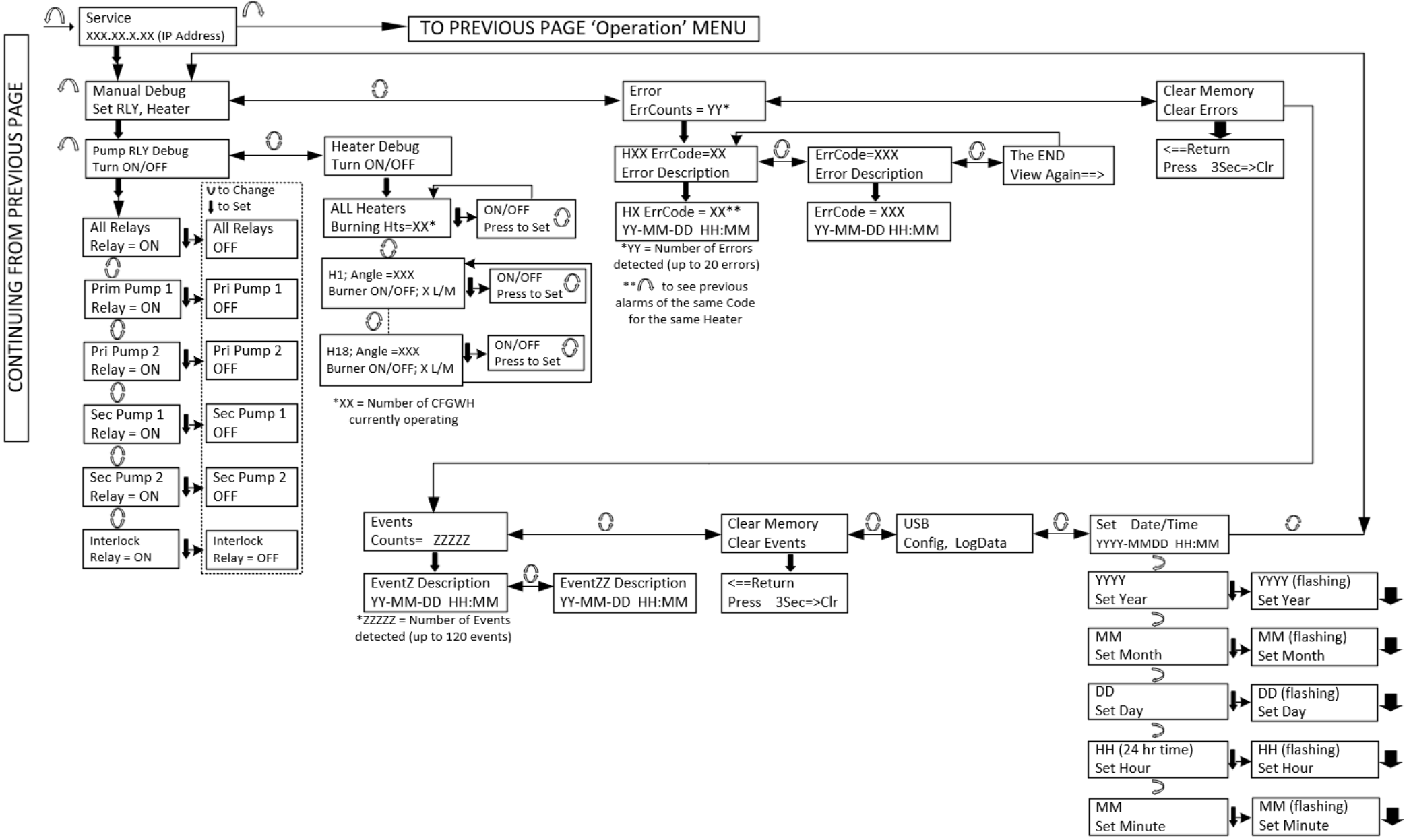

MODIFYING TANKPAK DELUXE CONTROLLER TEMPERATURE SETTINGS

Tankpak Deluxe controller is factory supplied pre-set to maintain a tank temperature set point of 65°C, with a tank differential of 3 °C.

The parameters of the controller may need to be adjusted to achieve the desired system operating temperature should it differ from the factory setting.

Refer to the Deluxe Controller Display Menu on [page 71](#) for navigating through the menu and go to Settings.

Then follow the table below to modify the temperature settings as required.

DELUXE CONTROLLER PARAMETER SETTINGS

	Parameter	Sub Parameter	Default Value	Range	
Settings	Setpoint CFGWH	XX°C (Flashing) Modify Temp	70°C	40-80°C	
	Setpoint Tank	XX°C (Flashing) Modify Temp	65C	40-70°C	
	Set Diff Tank (Tank temperature differential)	XX°C (Flashing) Modify Temp	3C	3-10°C	
	SP 2ndry Pump (Building pump set point)	XX°C (Flashing) Modify Temp	60C	40-75°C	
	Diff 2ndry Pump (Building pump temperature differential)	XX°C (Flashing) Modify Temp	3C	3-10°C	
	Set Model Type	Select Options	TankPAK	TankPAK/CommPak	
	Set CEM Ht Num (Set Control Extension Module Heater Number)	CEM0=6 ; CEM1=0 CEM2=0 ; CEM3=0	System dependent	1-6	
	Cfg Pump (Configure Pump)	Primary Pump P1=NO; P2=NO		-	-
		Primary Pump P1=YES; P2=NO		Single primary pump	-
		Primary Pump P1=YES; P2=YES		Duty/Standby primary pump	-
		Secondary Pump P1=NO; P2=NO		-	-
		Secondary Pump P1=YES; P2=NO		Single secondary pump	-
		Secondary Pump P1=YES; P2=YES		Duty/Standby secondary pump	-
		2ndry Pump Swap (Secondary pump rotation period) 360 Minutes		360 minutes	-
		2ndry Pump Swap (Secondary pump rotation period) 180 Minutes		-	-
		2ndry Pump Swap (Secondary pump rotation period) 30 Minutes		-	-
	Network Setup	DHCP Disabled Disabled/Enabled		Disabled	DO NOT MODIFY
		Static IP Address XXX.XX.X.XX		System dependent	DO NOT MODIFY
		Setup MASK XXX.XXX.XXX.X		System dependent	DO NOT MODIFY
		Setup Gateway XXX.XX.X.X		System dependent	DO NOT MODIFY

MODIFYING UPM PUMP SPEED SETTING

To reduce potential velocity issues in return lines, building circulators should be set at the lowest speed possible to maintain the desired temperature in the ring main.

The pump speed setting on the UPM3 or UPMXL secondary pumps may be adjusted as required on site by following below procedures:

- UPM3 pumps
 - Navigate to “Service” > “Manual Debug” > “Relay Debug” > “Sec Pump 1” then set to ON. The relay is energised and Secondary Pump 1 is turned on.
 - On the UPM3 pump panel, press and hold the button for 2 seconds. The red and orange LEDs are blinking.
 - Toggle through the pump speed settings by pressing the button until the desired profile from below speed setting is selected.
 - Leave the pump untouched for 10 seconds. The panel should show green and orange LEDs continuously.
 - Repeat the above steps for “Sec Pump 2”, Secondary Pump 2.

WITHOUT SIGNAL							
CONTROL MODE	MODE	xx-20	xx-50	xx-70			
MAX CURVE 1		0.5 m	2 m	4 m			
MAX CURVE 2		1 m	3 m	5 m			
MAX CURVE 3		1.5 m	4 m	6 m			
MAX CURVE 4		2 m	5 m	7 m			

- UPMXL pumps
 - Navigate to “Service” > “Manual Debug” > “Relay Debug” > “Sec Pump 1” then set to ON. The relay is energised and Secondary Pump 1 is turned on.
 - Note that UPMXL has “proportional pressure” (PP) and “constant pressure” (CP) modes, as well as AUTO ADAPT (3 LED bars lit) for each mode.
 - On the UPMXL pump panel, press and hold the button for 2 seconds. The green LED is blinking (fast for “proportional pressure” and slow for “constant pressure”).
 - Toggle through the pump speed settings by pressing the button until the desired profile from below speed setting is selected.
 - Leave the pump untouched for 10 seconds. The panel should show green and orange LEDs continuously.
 - Repeat the above steps for “Sec Pump 2”, Secondary Pump 2.

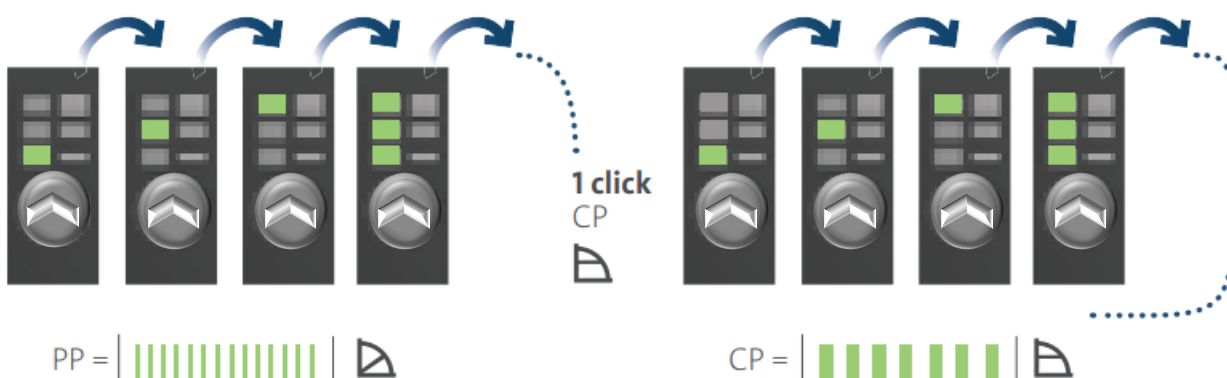

TO TURN OFF THE WATER HEATER

If it is necessary to turn off the water heater on completion of the installation, such as on a building site or where the premises is vacant, then:

- Switch off the electrical supply at the isolating switch to the Tankpak (refer to Note below).
- Close the gas isolation valve at the inlet to the Tankpak.
- Close the cold water and hot water flow isolation valves at the inlet and outlet of the Tankpak
- Close the isolation valves on the inlet and outlet at the storage tank(s).
- Drain each CFWH if there is a risk of freezing conditions occurring (refer to [“Draining The Water Heater”](#) on **page 75**).

Notes:

- The frost protection system will be rendered inoperable if electrical power is not available at the water heater.
- Damage caused by freezing due to the unavailability of power at the water heater is not covered by the Rheem warranty (refer to [“Terms of the Rheem Warranty”](#) on **page 4**).
- If the power has been switched off to the water heater and there is a risk of freezing, then it is necessary to drain the water heater (refer to [“Draining the Water Heater”](#) on **page 75**).

DRAINING THE WATER HEATER

To drain the water heater:

- Turn off the water heater (refer to [“Turn Off The Water Heater”](#) on **page 11**).
- Unscrew the two drain plugs, one each at the cold water inlet and hot water outlet, on the underside of each continuous flow water heater.

Water will drain from the water heaters.

Note: It is recommended not to screw the drain plugs back in, until the water heater is to be turned on again.

FINAL CHECKS

1. Check system for any leaks (gas and water)
 2. Turn system 240V AC power OFF.
 - Isolate main water valves
 - Check and clean strainers on each of CFWH cold water inlet and pump inlet.
 3. Advise customer to check strainers after 1 week usage.
 - Continue to check strainers on a weekly basis until they inspect clean.
 - Continue to check strainers on a monthly basis until they inspect clean.
 - Continue to check strainers on a Quarterly basis until they inspect clean.
 - Thereafter check every six (6) months.
 4. Open all isolating valves
 5. Turn power ON.
 6. Fill in commissioning sheet (refer page 77). Rheem Tankpak can now be left on line.
- Finish.

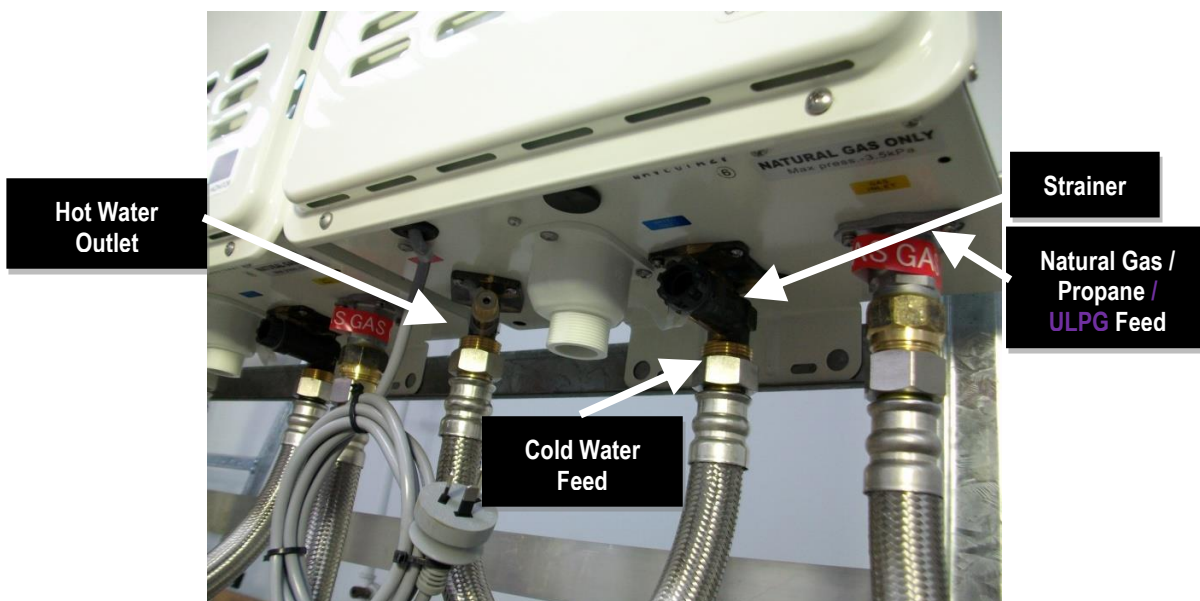

TANKPAK SERIES 3– COMMISSIONING SHEET

Customer:

Project and Address:

Package Details:

Installation	OK	Comments
Overall installation?		
Flueing ventilation requirements?		Compliance to AS/NZS5601.1 is mandatory
Co-axial Flueing		Compliance to AS/ZNS5601.1 is mandatory Refer: Flueing <u>page 44</u>
Tank manifolding correct		
		Refer to <u>page 41</u> and storage installation instructions
Fuel: Natural Gas / LPG		
Gas pressure during full load operation?		Natural Gas: 1.13 minimum & 3.5 kPa maximum Propane / ULPG: 2.75 minimum & 3.5 kPa maximum
Inlet Water Pressure		
Inlet water pressure?		Minimum 350 kPa & up to 800 kPa (Tank dependant)
Valves		
All the valves are in open position?		
System		
All water heaters are operating?		
System temperature is satisfactory?		
Comments		
Controller setting		
CFWH setting		

Client to carry out regular preventative maintenance as below:
 water heater inlet strainers & system inlet strainer
 Check & clean as per the schedule – **Refer Page 76 – Commissioning - Final Checks**

Sign Off

System Commissioned By:

Customer’s Representative:

Date:

Date:

TANKPAK – FAULT FINDING PROCEDURE

TROUBLE SHOOTING

When a complaint is lodged about the performance of a hot water system there are several causes that should be checked and eliminated. In an attempt to pinpoint the most likely cause it is important to discuss with the customer their reasons for the complaint, the duration of the problem, any change in circumstances or usage. This information in conjunction with the following listed common complaints will assist you in locating the most likely cause.

The Deluxe Master controller will log and time stamp all CFWH and system errors. Refer to the Deluxe Controller Display Menu on [page 71](#) for navigating through the menu and go to 'Service'.

Fault	Possible Causes	Description & Recommended Corrective Action
No hot water	Gas Failure	<ul style="list-style-type: none"> Check gas supply and reinstate
	Power Failure	<ul style="list-style-type: none"> Check and reinstate power supplies to all the power outlets.
	Water Supply Failure	<ul style="list-style-type: none"> Check adequate cold water supply is available to all CFWH & no valves are shut. Check for minimum 350kPa water supply pressure available. Check CFWH and inlet strainers for cleanliness
	Primary Circuit	<ul style="list-style-type: none"> Check plumbing of primary circuit is as per instructions. If the storage tank is not in relative close proximity to the CFWH, or there are more than 8 bends in the primary circuit, or piping is undersized, this may have an impact on primary pump performance. Flow rate through each CFWH can be read off the Master Controller. Refer to Rheem Service
	CFWH Fault	<ul style="list-style-type: none"> Note error code on Master Controller and contact Rheem Service
Long delay for hot water supply	Recirculation Pump Fault	<ul style="list-style-type: none"> Check secondary circulator Is the secondary circulator sized correctly for the flow and return design? Check balancing valves settings (if installed)
No digital display		<ul style="list-style-type: none"> Power outage Loose or open circuit wiring Thermostat faulty Direct sunlight on LCD
Water too hot	Temperature sensor not sensing temperature	<ul style="list-style-type: none"> Ensure the operating thermostat temperature probe is fully inserted into cylinder temperature sensing well and is unhindered in its ability to accurately sense the cylinder temperature.

TANKPAK – FAULT FINDING PROCEDURE WITH STANDARD CONTROLLER

The ERROR LED (RED) will flash if there is an error, the details as the table below:

Error Type	RED LED Flash times	Diagnostic
CFWH	1	Refer to Error Code for CFWH Unit
Blocked CFWH filter	2	Remove and clean filters
Water Flow Sensor	3	Refer to Rheem Service
Smartec Interface	4	Check Smartec Cable
Temperature sensor	5	Check PT1000 Cable and Sensor.
Pump Failure	6	Check Pump and Cable
12V DC Power Supply failure	7	Check Power Supply
Tank Sensor not inserted correctly in thermowell	8	Check Sensor position (and insert it fully in the thermowell).

TANKPAK – FAULT FINDING PROCEDURE WITH DELUXE CONTROLLER**ERROR CODE FOR DELUXE CONTROLLER**

Deluxe Controller Display	Error	Cause of Error	Diagnostic
HXX ErrCode = 5 to 99, Error Description	CFGWH error	various	Refer to Rheem Service
e.g. HXX ErrCode = 11, Ignition Fail	CFGWH number Ignition failure	Insufficient gas supply pressure	Check gas pressure and purge lines
e.g. HXX ErrCode = 12, Flame Fail	CHGWH number Loss of flame	Insufficient gas supply pressure	Check gas pressure and purge lines
e.g. HXX ErrCode = 21, Restrictor BLK	CFGWH number Inlet Filter Blockage	Insufficient or no water flow	Check water supply and clean inlet filter on indicated CFGWH
ErrCode = 111, HXX Smartec Comms	Smartec interface	Lost communication with CFGWH	Check Smartec Cable on indicated CFWH
ErrCode = 112, CEM XX Modbus RS485	Modbus RS485	Lost communication with CEM	Check RS485 Cable and CEM
ErrCode = 121, Tank Sensor	Tank Bottom Temperature Sensor	Sensor cable open circuit or short circuit	Check PT1000 cable and sensor
ErrCode = 122, Bldg Rtn Sensor	Building Return Temperature Sensor	Sensor cable open circuit or short circuit	Check PT1000 cable and sensor
ErrCode = 123, Bldg Flo Sensor	Building Flow Temperature Sensor	Sensor cable open circuit or short circuit	Check PT1000 cable and sensor
ErrCode = 124, Tank Sensr OnAir	Tank Bottom Temperature Sensor	Tank Sensor not fully inserted into the sensor well	Check Sensor position (and insert it fully in the thermowell).
ErrCode = 131, PP1 No Flow	Primary Pump1	Faulty pump or cable	Check pump and cable
ErrCode = 132, PP2 No Flow	Primary Pump2	Faulty pump or cable	Check pump and cable
ErrCode = 133, SP1 No Flow	Secondary Pump1	Faulty pump or cable	Check pump and cable
ErrCode = 134, SP2 No Flow	Secondary Pump2	Faulty pump or cable	Check pump and cable

This page is intentionally blank

APPENDIX 1 – LIFTING AND ROOF INSTALLATION



Relationships built on trust

Gamcorp (Melbourne) Pty Ltd A.C.N 141 076 904 A.B.N 73 015 060 240
www.gamcorp.com.au melbourne@gamcorp.com.au
 Suite 4, 346 Ferntree Gully Rd, Notting Hill VIC 3168
 Tel: 03 9543 2211 Fax: 03 9543 4046



Our Ref: 5601-Rev1/AA

27 March 2019

Rheem Australia
 467 Warrigal Rd
 Moorabbin VIC 3189

RE: Structural Assessment for Roof Mounted System - Tankpak

Gamcorp (Melbourne) Pty Ltd, being Structural Engineers within the meaning of Australian Building Regulations, have carried out a structural design check of the CFWH water heater support frame to be installed on top of the roofs. The calculations have been based on the drawing "Tankpak Schematics TPE18 & UPS3280 DS", Rev. 3 Sh1 dated 25/03/2019, technical information and site specific information provided by Rheem Australia.

We find the support frame to be structurally sufficient for lifting and installation on top of roofs, based on the following conditions:

- Loading to:
 - AS/NZS1170.0:2002 – Structural design actions, Part 0: General principles;
 - AS/NZS1170.1:2002 – Structural design actions, Part 1: Permanent, imposed and other actions;
 - AS/NZS1170.2:2011 (R2016) – Structural design actions, Part 2: Wind actions;
- Design to:
 - AS4100:1998 (R2016) – Steel structures;
 - AS/NZS4600-2005 – Cold-formed steel structures;
- Wind Regions A & B;
- Maximum roof height 45m;
- Terrain Category 2;
- Wind average recurrence interval of 500 years
- $M_d=1$, $M_s=1$, $M_t=1$;
- Steel frame material HA250 U.N.O.;
- Anchor Bolts, Ramset DynaBolt Plus Anchor, 12mm (DP12060GH), 40mm embedment (or equivalent) for concrete roofs with minimum compressive strength, $f'c=20$ Mpa, to be installed in accordance with manufacturer technical data sheet;
- Maximum assembled frames length 3.27m, with maximum Nett weight 790kg and maximum lifting weight 990kg;
- Every Upright Ext to be used for lifting through bracket lifting;
- Support chains to be angled at more than 60 degrees from the horizontal or less than 30 degrees from the vertical.

This certificate does not cover any of the mechanical equipment, piping etc associated with the CFWH units nor ancillary brackets/mounting plates or cable fixing panel which are the responsibility of others. In addition, this certificate does not cover the chosen corrosion protection system for the steelwork.

ISO 9001:2008 Registered Firm
 Certificate No: AU1222



Relationships built on trust



Gamcorp (Melbourne) Pty Ltd A.C.N 141 076 904 A.B.N 73 015 060 240
www.gamcorp.com.au melbourne@gamcorp.com.au
 Suite 4, 346 Ferntree Gully Rd, Notting Hill VIC 3168
 Tel: 03 9543 2211 Fax: 03 9543 4046

This work was designed by **Ali Askari** in accordance with the provisions of Australian Building Regulations and in accordance with sound, widely accepted engineering principles.

This certification is applicable for the CFWH Roof Mounted Systems with dimensions as shown in this letter attachments and is valid for two years. Contact Gamcorp for customised system or if the site conditions are not covered by this assessment

Yours faithfully,
 Gamcorp (Melbourne) Pty Ltd

Jianzeng Geng
 Principal Engineer
 FIEAust CPEng NER 3108316
 NT Registration: 239858ES
 QLD Registration: 18455
 VIC Registration: EC 39483
 TAS Registration: CC7263

Attached drawings:

- WELDED FRAME ASSY 2BAY, Rev. 2 Sh1,2 dated 25/03/2019
- WELDED FRAME ASSY 3BAY, Rev. 2 Sh1,2 dated 25/03/2019
- WELDED FRAME ASSY 4BAY, Rev. 2 Sh1,2 dated 25/03/2019
- BOLTED FRAME ASSEMBLY 9 BAY BB WITH NOTES, Rev. 1 Sh1 dated 08/03/2019
- BASE WELDED ASSY FM/BB LHS, Rev. 1 Sh1 dated 07/11/2018
- BASE WELDED ASSY FM/BB RHS, Rev. 1 Sh1 dated 07/11/2018
- BRACKET LIFTING STRAIGHT, Rev. 1 Sh1 dated 01/11/2018
- BRACKET LIFTING OFFSET, Rev. 1 Sh1 dated 01/11/2018

*ISO 9001:2008 Registered Firm
 Certificate No: AU1222*

This page is intentionally blank



RHEEM AUSTRALIA PTY LTD
A.B.N. 21 098 823 511
www.rheem.com.au

FOR SERVICE TELEPHONE
131 031 AUSTRALIA
0800 657 335 NEW ZEALAND

Revision Date: April 2022
AQ0901129 Revision E
EPCR: 220202